

- 고정도강(HRc52~68), 프리하든강 계열의 고정밀 가공 엔드밀
- 고품질 실리콘계 코팅(Si) 처리하여 내마모성이 우수합니다.
- 고정밀 공차 적용으로 초정밀 가공에 적합합니다.
- 날부인선의 조도가 뛰어나 피삭재의 면조도가 우수합니다.
- 초미립자 초경합금(0.2µm)을 채택, 고속절삭시 뛰어난 성능을 발휘합니다.

#### Endmills for pre-hardened and hardened steels(HRc52~68)

- Good wear resistance by high quality Si-based PVD coating.
- High precise edge tolerance.
- Excellent surface finish.
- Very nice work surface finish.
- Outstanding performance at high speed machining by ultra fine (0.2µm) WC grade.

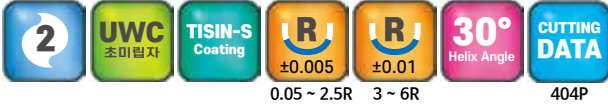

0.05 ~ 2.5R 3 ~ 6R 404P

Condition	D Size	D Tolerance	Condition	D Size	D Tolerance
ØD ≠ Ød	Ø0.1 ~ 0.15	+0 ~ -0.005mm	ØD = Ød	Ø6 ~ 12	-0.005 ~ -0.015mm
	Ø0.2 ~ 12	+0 ~ -0.01mm			

단위 : mm

Order Number	날경 Diameter R × D	날장 Length of cut L1	유효장 Effective Length L2	전장 Overall Length L	샙크 Shank Dia d	비고
2JJRB 001 003 S04	0.05R X 0.1	0.15	0.3	40	4	
2JJRB 001 005 S04	0.05R X 0.1	0.15	0.5	40	4	
2JJRB 0015 003 S04	0.075R X 0.15	0.15	0.3	40	4	
2JJRB 0015 005 S04	0.075R X 0.15	0.15	0.5	40	4	
2JJRB 0015 010 S04	0.075R X 0.15	0.15	1	40	4	
2JJRB 002 005 S04	0.1R X 0.2	0.2	0.5	40	4	
2JJRB 002 010 S04	0.1R X 0.2	0.2	1	40	4	
2JJRB 002 015 S04	0.1R X 0.2	0.2	1.5	40	4	
2JJRB 002 020 S04	0.1R X 0.2	0.2	2	40	4	
2JJRB 002 025 S04	0.1R X 0.2	0.2	2.5	40	4	
2JJRB 002 030 S04	0.1R X 0.2	0.2	3	40	4	
2JJRB 0025 005 S04	0.125R X 0.25	0.25	0.5	40	4	
2JJRB 0025 010 S04	0.125R X 0.25	0.25	1	40	4	
2JJRB 0025 015 S04	0.125R X 0.25	0.25	1.5	40	4	
2JJRB 0025 020 S04	0.125R X 0.25	0.25	2	40	4	
2JJRB 0025 025 S04	0.125R X 0.25	0.25	2.5	40	4	
2JJRB 0025 030 S04	0.125R X 0.25	0.25	3	40	4	
2JJRB 003 010 S04	0.15R X 0.3	0.3	1	40	4	
2JJRB 003 015 S04	0.15R X 0.3	0.3	1.5	40	4	
2JJRB 003 020 S04	0.15R X 0.3	0.3	2	40	4	
2JJRB 003 025 S04	0.15R X 0.3	0.3	2.5	40	4	
2JJRB 003 030 S04	0.15R X 0.3	0.3	3	40	4	
2JJRB 003 035 S04	0.15R X 0.3	0.3	3.5	40	4	
2JJRB 003 040 S04	0.15R X 0.3	0.3	4	40	4	
2JJRB 003 050 S04	0.15R X 0.3	0.3	5	40	4	
2JJRB 004 010 S04	0.2R X 0.4	0.4	1	40	4	
2JJRB 004 015 S04	0.2R X 0.4	0.4	1.5	40	4	
2JJRB 004 020 S04	0.2R X 0.4	0.4	2	40	4	
2JJRB 004 025 S04	0.2R X 0.4	0.4	2.5	40	4	
2JJRB 004 030 S04	0.2R X 0.4	0.4	3	40	4	
2JJRB 004 035 S04	0.2R X 0.4	0.4	3.5	40	4	
2JJRB 004 040 S04	0.2R X 0.4	0.4	4	40	4	
2JJRB 004 045 S04	0.2R X 0.4	0.4	4.5	40	4	
2JJRB 004 050 S04	0.2R X 0.4	0.4	5	40	4	
2JJRB 004 060 S04	0.2R X 0.4	0.4	6	40	4	
2JJRB 004 080 S04	0.2R X 0.4	0.4	8	40	4	
2JJRB 005 010 S04	0.25R X 0.5	0.5	1	45	4	
2JJRB 005 010 S06	0.25R X 0.5	0.5	1	50	6	
2JJRB 005 015 S04	0.25R X 0.5	0.5	1.5	45	4	
2JJRB 005 020 S04	0.25R X 0.5	0.5	2	45	4	
2JJRB 005 020 S06	0.25R X 0.5	0.5	2	50	6	
2JJRB 005 025 S04	0.25R X 0.5	0.5	2.5	45	4	
2JJRB 005 030 S04	0.25R X 0.5	0.5	3	45	4	
2JJRB 005 030 S06	0.25R X 0.5	0.5	3	50	6	
2JJRB 005 035 S04	0.25R X 0.5	0.5	3.5	45	4	
2JJRB 005 040 S04	0.25R X 0.5	0.5	4	45	4	
2JJRB 005 040 S06	0.25R X 0.5	0.5	4	50	6	
2JJRB 005 045 S04	0.25R X 0.5	0.5	4.5	45	4	
2JJRB 005 050 S04	0.25R X 0.5	0.5	5	45	4	
2JJRB 005 050 S06	0.25R X 0.5	0.5	5	50	6	

Order Number	날경 Diameter R × D	날장 Length of cut L1	유효장 Effective Length L2	전장 Overall Length L	샙크 Shank Dia d	비고
2JJRB 005 060 S04	0.25R X 0.5	0.5	6	45	4	
2JJRB 005 060 S06	0.25R X 0.5	0.5	6	50	6	
2JJRB 005 080 S04	0.25R X 0.5	0.5	8	45	4	
2JJRB 005 100 S04	0.25R X 0.5	0.5	10	45	4	
2JJRB 005 120 S04	0.25R X 0.5	0.5	12	45	4	
2JJRB 006 010 S04	0.3R X 0.6	0.6	1	45	4	
2JJRB 006 010 S06	0.3R X 0.6	0.6	1	50	6	
2JJRB 006 020 S04	0.3R X 0.6	0.6	2	45	4	
2JJRB 006 020 S06	0.3R X 0.6	0.6	2	50	6	
2JJRB 006 030 S04	0.3R X 0.6	0.6	3	45	4	
2JJRB 006 030 S06	0.3R X 0.6	0.6	3	50	6	
2JJRB 006 040 S04	0.3R X 0.6	0.6	4	45	4	
2JJRB 006 040 S06	0.3R X 0.6	0.6	4	50	6	
2JJRB 006 050 S04	0.3R X 0.6	0.6	5	45	4	
2JJRB 006 050 S06	0.3R X 0.6	0.6	5	50	6	
2JJRB 006 060 S04	0.3R X 0.6	0.6	6	45	4	
2JJRB 006 060 S06	0.3R X 0.6	0.6	6	50	6	
2JJRB 006 080 S04	0.3R X 0.6	0.6	8	45	4	
2JJRB 006 080 S06	0.3R X 0.6	0.6	8	50	6	
2JJRB 006 100 S04	0.3R X 0.6	0.6	10	45	4	
2JJRB 006 120 S04	0.3R X 0.6	0.6	12	45	4	
2JJRB 006 140 S04	0.3R X 0.6	0.6	14	45	4	
2JJRB 007 020 S04	0.35R X 0.7	0.7	2	45	4	
2JJRB 007 040 S04	0.35R X 0.7	0.7	4	45	4	
2JJRB 007 060 S04	0.35R X 0.7	0.7	6	45	4	
2JJRB 007 080 S04	0.35R X 0.7	0.7	8	45	4	
2JJRB 007 100 S04	0.35R X 0.7	0.7	10	45	4	
2JJRB 007 120 S04	0.35R X 0.7	0.7	12	45	4	
2JJRB 008 020 S04	0.4R X 0.8	0.8	2	45	4	
2JJRB 008 020 S06	0.4R X 0.8	0.8	2	50	6	
2JJRB 008 030 S04	0.4R X 0.8	0.8	3	45	4	
2JJRB 008 030 S06	0.4R X 0.8	0.8	3	50	6	
2JJRB 008 040 S04	0.4R X 0.8	0.8	4	45	4	
2JJRB 008 040 S06	0.4R X 0.8	0.8	4	50	6	
2JJRB 008 050 S04	0.4R X 0.8	0.8	5	45	4	
2JJRB 008 050 S06	0.4R X 0.8	0.8	5	50	6	
2JJRB 008 060 S04	0.4R X 0.8	0.8	6	45	4	
2JJRB 008 060 S06	0.4R X 0.8	0.8	6	50	6	
2JJRB 008 080 S04	0.4R X 0.8	0.8	8	45	4	
2JJRB 008 080 S06	0.4R X 0.8	0.8	8	50	6	
2JJRB 008 100 S04	0.4R X 0.8	0.8	10	45	4	
2JJRB 008 120 S04	0.4R X 0.8	0.8	12	45	4	
2JJRB 009 040 S04	0.45R X 0.9	0.9	4	45	4	
2JJRB 009 060 S04	0.45R X 0.9	0.9	6	45	4	
2JJRB 009 080 S04	0.45R X 0.9	0.9	8	45	4	
2JJRB 009 100 S04	0.45R X 0.9	0.9	10	50	4	
2JJRB 009 120 S04	0.45R X 0.9	0.9	12	50	4	
2JJRB 010 020 S04	0.5R X 1	1	2	45	4	
2JJRB 010 020 S06	0.5R X 1	1	2	50	6	
2JJRB 010 030 S04	0.5R X 1	1	3	45	4	

단위 : mm

Order Number	날경 Diameter R × D	날장 Length of cut L1	유효장 Effective Length L2	전장 Overall Length L	샙크 Shank Dia d	비고	Order Number	날경 Diameter R × D	날장 Length of cut L1	유효장 Effective Length L2	전장 Overall Length L	샙크 Shank Dia d	비고
2JJRB 010 030 S06	0.5R X 1	1	3	50	6		2JJRB 015 160 S04	0.75R X 1.5	1.5	16	50	4	
2JJRB 010 040 S04	0.5R X 1	1	4	45	4		2JJRB 015 160 S06	0.75R X 1.5	1.5	16	60	6	
2JJRB 010 040 S06	0.5R X 1	1	4	50	6		2JJRB 015 180 S04	0.75R X 1.5	1.5	18	50	4	
2JJRB 010 050 S04	0.5R X 1	1	5	45	4		2JJRB 015 200 S04	0.75R X 1.5	1.5	20	50	4	
2JJRB 010 050 S06	0.5R X 1	1	5	50	6		2JJRB 015 220 S04	0.75R X 1.5	1.5	22	60	4	
2JJRB 010 060 S04	0.5R X 1	1	6	45	4		2JJRB 015 250 S04	0.75R X 1.5	1.5	25	60	4	
2JJRB 010 060 S06	0.5R X 1	1	6	50	6		2JJRB 015 300 S04	0.75R X 1.5	1.5	30	70	4	
2JJRB 010 080 S04	0.5R X 1	1	8	45	4		2JJRB 016 060 S04	0.8R X 1.6	1.6	6	45	4	
2JJRB 010 080 S06	0.5R X 1	1	8	50	6		2JJRB 016 080 S04	0.8R X 1.6	1.6	8	45	4	
2JJRB 010 100 S04	0.5R X 1	1	10	50	4		2JJRB 016 120 S04	0.8R X 1.6	1.6	12	50	4	
2JJRB 010 100 S06	0.5R X 1	1	10	50	6		2JJRB 016 160 S04	0.8R X 1.6	1.6	16	50	4	
2JJRB 010 120 S04	0.5R X 1	1	12	50	4		2JJRB 016 200 S04	0.8R X 1.6	1.6	20	50	4	
2JJRB 010 120 S06	0.5R X 1	1	12	50	6		2JJRB 018 060 S04	0.9R X 1.8	1.8	6	45	4	
2JJRB 010 140 S04	0.5R X 1	1	14	50	4		2JJRB 018 080 S04	0.9R X 1.8	1.8	8	45	4	
2JJRB 010 160 S04	0.5R X 1	1	16	50	4		2JJRB 018 120 S04	0.9R X 1.8	1.8	12	50	4	
2JJRB 010 180 S04	0.5R X 1	1	18	50	4		2JJRB 018 160 S04	0.9R X 1.8	1.8	16	50	4	
2JJRB 010 200 S04	0.5R X 1	1	20	50	4		2JJRB 018 200 S04	0.9R X 1.8	1.8	20	50	4	
2JJRB 010 220 S04	0.5R X 1	1	22	60	4		2JJRB 020 040 S04	1R X 2	2	4	45	4	
2JJRB 010 250 S04	0.5R X 1	1	25	60	4		2JJRB 020 040 S06	1R X 2	2	4	50	6	
2JJRB 012 040 S04	0.6R X 1.2	1.2	4	45	4		2JJRB 020 060 S04	1R X 2	2	6	45	4	
2JJRB 012 040 S06	0.6R X 1.2	1.2	4	50	6		2JJRB 020 060 S06	1R X 2	2	6	50	6	
2JJRB 012 060 S04	0.6R X 1.2	1.2	6	45	4		2JJRB 020 080 S04	1R X 2	2	8	45	4	
2JJRB 012 060 S06	0.6R X 1.2	1.2	6	50	6		2JJRB 020 080 S06	1R X 2	2	8	50	6	
2JJRB 012 080 S04	0.6R X 1.2	1.2	8	45	4		2JJRB 020 100 S04	1R X 2	2	10	50	4	
2JJRB 012 080 S06	0.6R X 1.2	1.2	8	50	6		2JJRB 020 100 S06	1R X 2	2	10	50	6	
2JJRB 012 100 S04	0.6R X 1.2	1.2	10	50	4		2JJRB 020 120 S04	1R X 2	2	12	50	4	
2JJRB 012 100 S06	0.6R X 1.2	1.2	10	50	6		2JJRB 020 120 S06	1R X 2	2	12	50	6	
2JJRB 012 120 S04	0.6R X 1.2	1.2	12	50	4		2JJRB 020 140 S04	1R X 2	2	14	50	4	
2JJRB 012 120 S06	0.6R X 1.2	1.2	12	50	6		2JJRB 020 140 S06	1R X 2	2	14	50	6	
2JJRB 012 160 S04	0.6R X 1.2	1.2	16	50	4		2JJRB 020 160 S04	1R X 2	2	16	50	4	
2JJRB 012 200 S04	0.6R X 1.2	1.2	20	50	4		2JJRB 020 160 S06	1R X 2	2	16	60	6	
2JJRB 012 240 S04	0.6R X 1.2	1.2	24	60	4		2JJRB 020 180 S04	1R X 2	2	18	50	4	
2JJRB 014 060 S04	0.7R X 1.4	1.4	6	45	4		2JJRB 020 180 S06	1R X 2	2	18	60	6	
2JJRB 014 080 S04	0.7R X 1.4	1.4	8	45	4		2JJRB 020 200 S04	1R X 2	2	20	50	4	
2JJRB 014 120 S04	0.7R X 1.4	1.4	12	50	4		2JJRB 020 200 S06	1R X 2	2	20	60	6	
2JJRB 014 160 S04	0.7R X 1.4	1.4	16	50	4		2JJRB 020 220 S04	1R X 2	2	22	60	4	
2JJRB 015 030 S04	0.75R X 1.5	1.5	3	45	4		2JJRB 020 250 S04	1R X 2	2	25	60	4	
2JJRB 015 030 S06	0.75R X 1.5	1.5	3	50	6		2JJRB 020 300 S04	1R X 2	2	30	60	4	
2JJRB 015 040 S04	0.75R X 1.5	1.5	4	45	4		2JJRB 025 080 S04	1.25R X 2.5	2.5	8	45	4	
2JJRB 015 040 S06	0.75R X 1.5	1.5	4	50	6		2JJRB 025 080 S06	1.25R X 2.5	2.5	8	50	6	
2JJRB 015 060 S04	0.75R X 1.5	1.5	6	45	4		2JJRB 025 100 S04	1.25R X 2.5	2.5	10	50	4	
2JJRB 015 060 S06	0.75R X 1.5	1.5	6	50	6		2JJRB 025 100 S06	1.25R X 2.5	2.5	10	50	6	
2JJRB 015 080 S04	0.75R X 1.5	1.5	8	45	4		2JJRB 025 120 S04	1.25R X 2.5	2.5	12	50	4	
2JJRB 015 080 S06	0.75R X 1.5	1.5	8	50	6		2JJRB 025 120 S06	1.25R X 2.5	2.5	12	50	6	
2JJRB 015 100 S04	0.75R X 1.5	1.5	10	50	4		2JJRB 025 160 S04	1.25R X 2.5	2.5	16	50	4	
2JJRB 015 100 S06	0.75R X 1.5	1.5	10	50	6		2JJRB 025 160 S06	1.25R X 2.5	2.5	16	60	6	
2JJRB 015 120 S04	0.75R X 1.5	1.5	12	50	4		2JJRB 025 200 S04	1.25R X 2.5	2.5	20	60	4	
2JJRB 015 120 S06	0.75R X 1.5	1.5	12	50	6		2JJRB 025 200 S06	1.25R X 2.5	2.5	20	60	6	
2JJRB 015 140 S04	0.75R X 1.5	1.5	14	50	4		2JJRB 025 250 S04	1.25R X 2.5	2.5	25	60	4	
2JJRB 015 140 S06	0.75R X 1.5	1.5	14	50	6		2JJRB 025 300 S04	1.25R X 2.5	2.5	30	70	4	

단위 : mm

Order Number	날경 Diameter R × D	날장 Length of cut L1	유효장 Effective Length L2	전장 Overall Length L	샙크 Shank Dia d	비고	Order Number	날경 Diameter R × D	날장 Length of cut L1	유효장 Effective Length L2	전장 Overall Length L	샙크 Shank Dia d	비고
2JJRB 030 060 S06	1.5R X 3	3	6	50	6								
2JJRB 030 080 S06	1.5R X 3	3	8	50	6								
2JJRB 030 100 S06	1.5R X 3	3	10	50	6								
2JJRB 030 120 S06	1.5R X 3	3	12	50	6								
2JJRB 030 160 S06	1.5R X 3	3	16	60	6								
2JJRB 030 200 S06	1.5R X 3	3	20	60	6								
2JJRB 030 250 S06	1.5R X 3	3	25	65	6								
2JJRB 030 300 S06	1.5R X 3	3	30	70	6								
2JJRB 030 350 S06	1.5R X 3	3	35	75	6								
2JJRB 030 400 S06	1.5R X 3	3	40	80	6								
2JJRB 030 450 S06	1.5R X 3	3	45	90	6								
2JJRB 030 500 S06	1.5R X 3	3	50	100	6								
2JJRB 035 100 S06	1.75R X 3.5	3.5	10	50	6								
2JJRB 035 150 S06	1.75R X 3.5	3.5	15	60	6								
2JJRB 035 200 S06	1.75R X 3.5	3.5	20	60	6								
2JJRB 035 250 S06	1.75R X 3.5	3.5	25	65	6								
2JJRB 035 300 S06	1.75R X 3.5	3.5	30	70	6								
2JJRB 035 350 S06	1.75R X 3.5	3.5	35	75	6								
2JJRB 035 400 S06	1.75R X 3.5	3.5	40	80	6								
2JJRB 040 080 S06	2R X 4	4	8	50	6								
2JJRB 040 100 S06	2R X 4	4	10	50	6								
2JJRB 040 120 S06	2R X 4	4	12	50	6								
2JJRB 040 160 S06	2R X 4	4	16	60	6								
2JJRB 040 200 S06	2R X 4	4	20	60	6								
2JJRB 040 250 S06	2R X 4	4	25	65	6								
2JJRB 040 300 S06	2R X 4	4	30	70	6								
2JJRB 040 350 S06	2R X 4	4	35	75	6								
2JJRB 040 400 S06	2R X 4	4	40	80	6								
2JJRB 040 450 S06	2R X 4	4	45	90	6								
2JJRB 040 500 S06	2R X 4	4	50	100	6								
2JJRB 050 160 S06	2.5R X 5	6	16	60	6								
2JJRB 050 200 S06	2.5R X 5	6	20	60	6								
2JJRB 050 250 S06	2.5R X 5	6	25	70	6								
2JJRB 050 300 S06	2.5R X 5	6	30	75	6								
2JJRB 050 400 S06	2.5R X 5	6	40	80	6								
2JJRB 050 450 S06	2.5R X 5	6	45	90	6								
2JJRB 050 500 S06	2.5R X 5	6	50	100	6								
2JJRB 060 150 S06	3R X 6	10	15	55	6								
2JJRB 060 300 100	3R X 6	10	30	100	6								
2JJRB 060 500 120	3R X 6	10	50	120	6								
2JJRB 080 250 060	4R X 8	12	25	60	8								
2JJRB 080 300 100	4R X 8	12	30	100	8								
2JJRB 080 600 120	4R X 8	12	60	120	8								
2JJRB 100 300 070	5R X 10	16	30	70	10								
2JJRB 100 450 100	5R X 10	16	45	100	10								
2JJRB 100 600 130	5R X 10	16	60	130	10								
2JJRB 120 300 075	6R X 12	18	30	75	12								
2JJRB 120 500 110	6R X 12	18	50	110	12								
2JJRB 120 600 130	6R X 12	18	60	130	12								

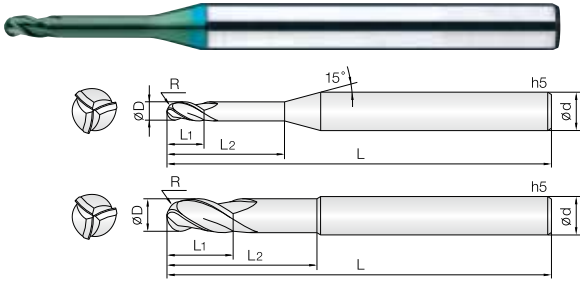

- 고정도강(HRc52~68), 프리하든강 계열의 고정밀 가공 엔드밀
- 고품량 실리콘계 코팅(Si) 처리하여 내마모성이 우수합니다.
- 고정밀 공차 적용으로 초정밀 가공에 적합합니다.
- 날부인선의 조도가 뛰어나 피삭재의 면조도가 우수합니다.
- 초미립자 초경합금(0.2 $\mu$ m)을 채택, 고속절삭시 뛰어난 성능을 발휘합니다.

#### • Endmills for pre-hardened and hardened steels(HRc52~68)

- Good wear resistance by high quality Si-based PVD coating.
- High precise edge tolerance.
- Excellent surface finish.
- Very nice work surface finish.
- Outstanding performance at high speed machining by ultra fine (0.2 $\mu$ m) WC grade.

3

UWC  
조미립자

TISIN-S  
Coating

R  
±0.005

R  
±0.01

30°  
Helix Angle

CUTTING  
DATA

0.5 ~ 2.5R      3 ~ 6R      406P

Condition	D Size	D Tolerance	Condition	D Size	D Tolerance
ØD ≠ ød	Ø1 ~ 12	+0 ~ -0.01mm	ØD = ød	Ø6 ~ 12	-0.005 ~ -0.015mm

단위 : mm

Order Number	날경 Diameter R × D	날장 Length of cut L1	유효장 Effective Length L2	전장 Overall Length L	샙크 Shank Dia d	비고	Order Number	날경 Diameter R × D	날장 Length of cut L1	유효장 Effective Length L2	전장 Overall Length L	샙크 Shank Dia d	비고
3JJRB 010 040 S04	0.5R X 1	1.2	4	50	4								
3JJRB 010 060 S04	0.5R X 1	1.2	6	50	4								
3JJRB 010 080 S04	0.5R X 1	1.2	8	50	4								
3JJRB 010 100 S04	0.5R X 1	1.2	10	50	4								
3JJRB 010 120 S04	0.5R X 1	1.2	12	50	4								
3JJRB 010 160 S04	0.5R X 1	1.2	16	50	4								
3JJRB 015 060 S04	0.75R X 1.5	1.8	6	50	4								
3JJRB 015 080 S04	0.75R X 1.5	1.8	8	50	4								
3JJRB 015 100 S04	0.75R X 1.5	1.8	10	50	4								
3JJRB 015 120 S04	0.75R X 1.5	1.8	12	50	4								
3JJRB 015 160 S04	0.75R X 1.5	1.8	16	50	4								
3JJRB 015 200 S04	0.75R X 1.5	1.8	20	60	4								
3JJRB 020 080 S04	1R X 2	2.4	8	50	4								
3JJRB 020 100 S04	1R X 2	2.4	10	50	4								
3JJRB 020 120 S04	1R X 2	2.4	12	50	4								
3JJRB 020 160 S04	1R X 2	2.4	16	50	4								
3JJRB 020 200 S04	1R X 2	2.4	20	60	4								
3JJRB 020 250 S04	1R X 2	2.4	25	70	4								
3JJRB 025 080 S04	1.25R X 2.5	3	8	50	4								
3JJRB 025 100 S04	1.25R X 2.5	3	10	50	4								
3JJRB 025 120 S04	1.25R X 2.5	3	12	50	4								
3JJRB 025 160 S04	1.25R X 2.5	3	16	50	4								
3JJRB 025 200 S04	1.25R X 2.5	3	20	60	4								
3JJRB 025 250 S04	1.25R X 2.5	3	25	70	4								
3JJRB 030 120 S06	1.5R X 3	3.6	12	60	6								
3JJRB 030 160 S06	1.5R X 3	3.6	16	60	6								
3JJRB 030 200 S06	1.5R X 3	3.6	20	65	6								
3JJRB 030 250 S06	1.5R X 3	3.6	25	70	6								
3JJRB 030 300 S06	1.5R X 3	3.6	30	75	6								
3JJRB 030 400 S06	1.5R X 3	3.6	40	90	6								
3JJRB 030 500 S06	1.5R X 3	3.6	50	100	6								
3JJRB 040 160 S06	2R X 4	4.8	16	60	6								
3JJRB 040 200 S06	2R X 4	4.8	20	65	6								
3JJRB 040 250 S06	2R X 4	4.8	25	70	6								
3JJRB 040 300 S06	2R X 4	4.8	30	75	6								
3JJRB 040 400 S06	2R X 4	4.8	40	90	6								
3JJRB 040 500 S06	2R X 4	4.8	50	100	6								
3JJRB 040 600 S06	2R X 4	4.8	60	110	6								
3JJRB 050 300 S06	2.5R X 5	6	30	75	6								
3JJRB 050 400 S06	2.5R X 5	6	40	90	6								
3JJRB 050 500 S06	2.5R X 5	6	50	100	6								
3JJRB 050 600 S06	2.5R X 5	6	60	110	6								
3JJRB 060 200 060	3R X 6	9	20	60	6								
3JJRB 060 300 090	3R X 6	9	30	90	6								
3JJRB 080 250 060	4R X 8	12	25	60	8								
3JJRB 080 400 100	4R X 8	12	40	100	8								
3JJRB 100 300 070	5R X 10	15	30	70	10								
3JJRB 100 500 110	5R X 10	15	50	110	10								
3JJRB 120 350 075	6R X 12	18	35	75	12								
3JJRB 120 600 110	6R X 12	18	60	110	12								

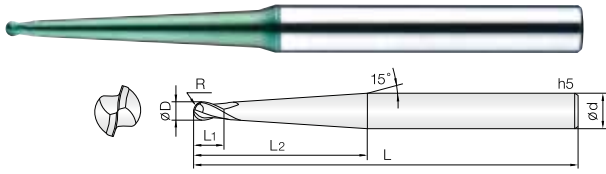

- 고정도강(HRc52~68), 프리하든강 계열의 고정밀 가공 엔드밀
- 고품량 실리콘계 코팅(Si) 처리하여 내마모성이 우수합니다.
- 유효장을 테이퍼 설계하여 깊은 홈 작업시 목부 파손 및 떨림을 최소화 하였습니다
- 고정밀 공차 적용으로 초정밀 가공에 적합합니다.
- 초미립자 초경합금(0.2 $\mu$ m)을 채택, 고속절삭시 뛰어난 성능을 발휘합니다.
- Endmills for pre-hardened and hardened steels(HRc52~68)
- Good wear resistance by high quality Si-based PVD coating.
- Minimize chattering and fracturing by taper designed flute.
- High precise edge tolerance.
- Outstanding performance at high speed machining by ultra fine (0.2 $\mu$ m) WC grade.

2

UWC  
초미립자

TISIN-S  
Coating

R  
±0.005

R  
±0.01

30°  
Helix Angle

CUTTING  
DATA

0.1 ~ 2.5R    3 ~ 6R    407P

Condition	D Size	D Tolerance
ØD ≠ ød	Ø0.2 ~ 12	+0 ~ -0.01mm

단위 : mm

Order Number	날경 Diameter R × D	각도 Angle θ	날장 Length of cut L1	유효장 Effective Length L2	전장 Overall Length L	샙크 Shank Dia d	비고	Order Number	날경 Diameter R × D	각도 Angle θ	날장 Length of cut L1	유효장 Effective Length L2	전장 Overall Length L	샙크 Shank Dia d	비고
2JJTB 002 003 015	0.1R X 0.2	0°30	0.2	1.5	40	4		2JJTB 004 013 030	0.2R X 0.4	1°30	0.4	3	40	4	
2JJTB 002 003 020	0.1R X 0.2	0°30	0.2	2	40	4		2JJTB 004 013 040	0.2R X 0.4	1°30	0.4	4	40	4	
2JJTB 002 010 015	0.1R X 0.2	1°	0.2	1.5	40	4		2JJTB 004 013 050	0.2R X 0.4	1°30	0.4	5	40	4	
2JJTB 002 010 020	0.1R X 0.2	1°	0.2	2	40	4		2JJTB 004 013 060	0.2R X 0.4	1°30	0.4	6	40	4	
2JJTB 002 010 025	0.1R X 0.2	1°	0.2	2.5	40	4		2JJTB 004 013 080	0.2R X 0.4	1°30	0.4	8	45	4	
2JJTB 002 013 015	0.1R X 0.2	1°30	0.2	1.5	40	4		2JJTB 004 020 020	0.2R X 0.4	2°	0.4	2	40	4	
2JJTB 002 013 020	0.1R X 0.2	1°30	0.2	2	40	4		2JJTB 004 020 030	0.2R X 0.4	2°	0.4	3	40	4	
2JJTB 002 013 025	0.1R X 0.2	1°30	0.2	2.5	40	4		2JJTB 004 020 040	0.2R X 0.4	2°	0.4	4	40	4	
2JJTB 002 020 015	0.1R X 0.2	2°	0.2	1.5	40	4		2JJTB 004 020 050	0.2R X 0.4	2°	0.4	5	40	4	
2JJTB 002 020 020	0.1R X 0.2	2°	0.2	2	40	4		2JJTB 004 020 060	0.2R X 0.4	2°	0.4	6	40	4	
2JJTB 002 020 025	0.1R X 0.2	2°	0.2	2.5	40	4		2JJTB 004 020 080	0.2R X 0.4	2°	0.4	8	45	4	
2JJTB 002 030 015	0.1R X 0.2	3°	0.2	1.5	40	4		2JJTB 004 020 100	0.2R X 0.4	2°	0.4	10	45	4	
2JJTB 002 030 020	0.1R X 0.2	3°	0.2	2	40	4		2JJTB 004 030 040	0.2R X 0.4	3°	0.4	4	45	4	
2JJTB 002 030 025	0.1R X 0.2	3°	0.2	2.5	40	4		2JJTB 004 030 060	0.2R X 0.4	3°	0.4	6	45	4	
2JJTB 002 030 030	0.1R X 0.2	3°	0.2	3	45	4		2JJTB 004 030 080	0.2R X 0.4	3°	0.4	8	45	4	
2JJTB 002 050 020	0.1R X 0.2	5°	0.2	2	40	4		2JJTB 004 030 100	0.2R X 0.4	3°	0.4	10	45	4	
2JJTB 002 050 030	0.1R X 0.2	5°	0.2	3	45	4		2JJTB 004 050 060	0.2R X 0.4	5°	0.4	6	45	4	
2JJTB 003 003 030	0.15R X 0.3	0°30	0.3	3	40	4		2JJTB 004 050 080	0.2R X 0.4	5°	0.4	8	45	4	
2JJTB 003 010 020	0.15R X 0.3	1°	0.3	2	40	4		2JJTB 004 050 100	0.2R X 0.4	5°	0.4	10	45	4	
2JJTB 003 010 030	0.15R X 0.3	1°	0.3	3	40	4		2JJTB 005 003 040	0.25R X 0.5	0°30	0.5	4	45	4	
2JJTB 003 010 040	0.15R X 0.3	1°	0.3	4	40	4		2JJTB 005 003 060	0.25R X 0.5	0°30	0.5	6	45	4	
2JJTB 003 010 050	0.15R X 0.3	1°	0.3	5	40	4		2JJTB 005 010 040	0.25R X 0.5	1°	0.5	4	45	4	
2JJTB 003 013 020	0.15R X 0.3	1°30	0.3	2	40	4		2JJTB 005 010 060	0.25R X 0.5	1°	0.5	6	45	4	
2JJTB 003 013 030	0.15R X 0.3	1°30	0.3	3	40	4		2JJTB 005 010 080	0.25R X 0.5	1°	0.5	8	45	4	
2JJTB 003 013 040	0.15R X 0.3	1°30	0.3	4	40	4		2JJTB 005 010 100	0.25R X 0.5	1°	0.5	10	45	4	
2JJTB 003 013 050	0.15R X 0.3	1°30	0.3	5	40	4		2JJTB 005 013 040	0.25R X 0.5	1°30	0.5	4	45	4	
2JJTB 003 020 020	0.15R X 0.3	2°	0.3	2	40	4		2JJTB 005 013 060	0.25R X 0.5	1°30	0.5	6	45	4	
2JJTB 003 020 030	0.15R X 0.3	2°	0.3	3	40	4		2JJTB 005 013 080	0.25R X 0.5	1°30	0.5	8	45	4	
2JJTB 003 020 040	0.15R X 0.3	2°	0.3	4	40	4		2JJTB 005 013 100	0.25R X 0.5	1°30	0.5	10	45	4	
2JJTB 003 020 050	0.15R X 0.3	2°	0.3	5	40	4		2JJTB 005 020 040	0.25R X 0.5	2°	0.5	4	45	4	
2JJTB 003 020 060	0.15R X 0.3	2°	0.3	6	45	4		2JJTB 005 020 060	0.25R X 0.5	2°	0.5	6	45	4	
2JJTB 003 030 020	0.15R X 0.3	3°	0.3	2	40	4		2JJTB 005 020 080	0.25R X 0.5	2°	0.5	8	45	4	
2JJTB 003 030 030	0.15R X 0.3	3°	0.3	3	40	4		2JJTB 005 020 100	0.25R X 0.5	2°	0.5	10	45	4	
2JJTB 003 030 040	0.15R X 0.3	3°	0.3	4	40	4		2JJTB 005 030 080	0.25R X 0.5	3°	0.5	8	45	4	
2JJTB 003 030 050	0.15R X 0.3	3°	0.3	5	40	4		2JJTB 005 030 120	0.25R X 0.5	3°	0.5	12	50	4	
2JJTB 003 030 060	0.15R X 0.3	3°	0.3	6	45	4		2JJTB 005 030 160	0.25R X 0.5	3°	0.5	16	60	4	
2JJTB 003 050 050	0.15R X 0.3	5°	0.3	5	40	4		2JJTB 005 030 200	0.25R X 0.5	3°	0.5	20	60	4	
2JJTB 003 050 080	0.15R X 0.3	5°	0.3	8	45	4		2JJTB 005 050 100	0.25R X 0.5	5°	0.5	10	50	4	
2JJTB 004 003 020	0.2R X 0.4	0°30	0.4	2	40	4		2JJTB 005 050 150	0.25R X 0.5	5°	0.5	15	60	4	
2JJTB 004 003 030	0.2R X 0.4	0°30	0.4	3	40	4		2JJTB 005 050 200	0.25R X 0.5	5°	0.5	20	60	4	
2JJTB 004 003 040	0.2R X 0.4	0°30	0.4	4	40	4		2JJTB 006 003 040	0.3R X 0.6	0°30	0.6	4	45	4	
2JJTB 004 003 050	0.2R X 0.4	0°30	0.4	5	40	4		2JJTB 006 003 060	0.3R X 0.6	0°30	0.6	6	45	4	
2JJTB 004 003 060	0.2R X 0.4	0°30	0.4	6	40	4		2JJTB 006 003 080	0.3R X 0.6	0°30	0.6	8	45	4	
2JJTB 004 010 020	0.2R X 0.4	1°	0.4	2	40	4		2JJTB 006 010 040	0.3R X 0.6	1°	0.6	4	45	4	
2JJTB 004 010 030	0.2R X 0.4	1°	0.4	3	40	4		2JJTB 006 010 060	0.3R X 0.6	1°	0.6	6	45	4	
2JJTB 004 010 040	0.2R X 0.4	1°	0.4	4	40	4		2JJTB 006 010 080	0.3R X 0.6	1°	0.6	8	45	4	
2JJTB 004 010 050	0.2R X 0.4	1°	0.4	5	40	4		2JJTB 006 010 100	0.3R X 0.6	1°	0.6	10	45	4	
2JJTB 004 010 060	0.2R X 0.4	1°	0.4	6	40	4		2JJTB 006 010 120	0.3R X 0.6	1°	0.6	12	50	4	
2JJTB 004 010 080	0.2R X 0.4	1°	0.4	8	45	4		2JJTB 006 010 150	0.3R X 0.6	1°	0.6	15	50	4	
2JJTB 004 013 020	0.2R X 0.4	1°30	0.4	2	40	4		2JJTB 006 010 200	0.3R X 0.6	1°	0.6	20	60	4	



단위: mm

Order Number	날경 Diameter R × D	각도 Angle θ	날장 Length of cut L1	유효장 Effective Length L2	전장 Overall Length L	생크 Shank Dia d	비고	Order Number	날경 Diameter R × D	각도 Angle θ	날장 Length of cut L1	유효장 Effective Length L2	전장 Overall Length L	생크 Shank Dia d	비고
2JJTB 015 013 500	0.75R X 1.5	1°30'	1.5	50	90	4		2JJTB 030 020 160	1.5R X 3	2°	3	16	60	6	
2JJTB 015 020 100	0.75R X 1.5	2°	1.5	10	50	4		2JJTB 030 020 200	1.5R X 3	2°	3	20	65	6	
2JJTB 015 020 150	0.75R X 1.5	2°	1.5	15	50	4		2JJTB 030 020 300	1.5R X 3	2°	3	30	70	6	
2JJTB 015 020 200	0.75R X 1.5	2°	1.5	20	60	4		2JJTB 030 020 480	1.5R X 3	2°	3	48	90	6	
2JJTB 015 020 300	0.75R X 1.5	2°	1.5	30	70	4		2JJTB 030 020 600	1.5R X 3	2°	3	60	110	8	
2JJTB 015 020 400	0.75R X 1.5	2°	1.5	40	80	6		2JJTB 030 020 700	1.5R X 3	2°	3	70	120	8	
2JJTB 015 020 500	0.75R X 1.5	2°	1.5	50	90	6		2JJTB 030 030 300	1.5R X 3	3°	3	30	70	6	
2JJTB 015 030 420	0.75R X 1.5	3°	1.5	42	80	6		2JJTB 030 030 500	1.5R X 3	3°	3	50	90	8	
2JJTB 015 050 250	0.75R X 1.5	5°	1.5	25	70	6		2JJTB 030 030 700	1.5R X 3	3°	3	70	120	10	
2JJTB 020 003 080	1R X 2	0°30'	2	8	50	4		2JJTB 030 050 330	1.5R X 3	5°	3	33	90	8	
2JJTB 020 003 120	1R X 2	0°30'	2	12	50	4		2JJTB 040 003 600	2R X 4	0°30'	4	60	100	6	
2JJTB 020 003 160	1R X 2	0°30'	2	16	50	4		2JJTB 040 003 700	2R X 4	0°30'	4	70	110	6	
2JJTB 020 003 200	1R X 2	0°30'	2	20	60	4		2JJTB 040 003 900	2R X 4	0°30'	4	90	130	6	
2JJTB 020 003 300	1R X 2	0°30'	2	30	70	4		2JJTB 040 010 500	2R X 4	1°	4	50	90	6	
2JJTB 020 003 400	1R X 2	0°30'	2	40	80	4		2JJTB 040 010 600	2R X 4	1°	4	60	100	6	
2JJTB 020 003 500	1R X 2	0°30'	2	50	90	4		2JJTB 040 010 700	2R X 4	1°	4	70	120	8	
2JJTB 020 010 080	1R X 2	1°	2	8	50	4		2JJTB 040 010 900	2R X 4	1°	4	90	150	8	
2JJTB 020 010 120	1R X 2	1°	2	12	50	4		2JJTB 040 013 450	2R X 4	1°30'	4	45	90	6	
2JJTB 020 010 160	1R X 2	1°	2	16	50	4		2JJTB 040 013 600	2R X 4	1°30'	4	60	110	8	
2JJTB 020 010 200	1R X 2	1°	2	20	60	4		2JJTB 040 013 700	2R X 4	1°30'	4	70	120	8	
2JJTB 020 010 250	1R X 2	1°	2	25	60	4		2JJTB 040 030 250	2R X 4	3°	4	25	70	6	
2JJTB 020 010 300	1R X 2	1°	2	30	70	4		2JJTB 040 030 420	2R X 4	3°	4	42	100	8	
2JJTB 020 010 350	1R X 2	1°	2	35	75	4		2JJTB 040 050 290	2R X 4	5°	4	29	90	8	
2JJTB 020 010 400	1R X 2	1°	2	40	80	4		2JJTB 050 010 400	2.5R X 5	1°	5	40	90	8	
2JJTB 020 010 500	1R X 2	1°	2	50	90	4		2JJTB 050 010 600	2.5R X 5	1°	5	60	110	8	
2JJTB 020 010 600	1R X 2	1°	2	60	100	6		2JJTB 050 010 900	2.5R X 5	1°	5	90	150	8	
2JJTB 020 013 080	1R X 2	1°30'	2	8	50	4		2JJTB 050 013 400	2.5R X 5	1°30'	5	40	90	8	
2JJTB 020 013 120	1R X 2	1°30'	2	12	50	4		2JJTB 050 013 600	2.5R X 5	1°30'	5	60	110	8	
2JJTB 020 013 160	1R X 2	1°30'	2	16	50	4		2JJTB 050 013 900	2.5R X 5	1°30'	5	90	150	10	
2JJTB 020 013 200	1R X 2	1°30'	2	20	60	4		2JJTB 050 030 400	2.5R X 5	3°	5	40	90	8	
2JJTB 020 013 250	1R X 2	1°30'	2	25	60	4		2JJTB 060 010 400	3R X 6	1°	9	40	90	8	
2JJTB 020 013 300	1R X 2	1°30'	2	30	70	4		2JJTB 060 010 500	3R X 6	1°	9	50	100	8	
2JJTB 020 013 350	1R X 2	1°30'	2	35	75	6		2JJTB 060 010 600	3R X 6	1°	9	60	110	8	
2JJTB 020 013 400	1R X 2	1°30'	2	40	80	6		2JJTB 060 010 700	3R X 6	1°	9	70	120	10	
2JJTB 020 013 500	1R X 2	1°30'	2	50	90	6		2JJTB 060 010 800	3R X 6	1°	9	80	130	10	
2JJTB 020 013 600	1R X 2	1°30'	2	60	100	6		2JJTB 060 010 1000	3R X 6	1°	9	100	150	10	
2JJTB 020 020 300	1R X 2	2°	2	30	70	6		2JJTB 060 013 490	3R X 6	1°30'	9	49	110	8	
2JJTB 020 020 400	1R X 2	2°	2	40	80	6		2JJTB 060 013 850	3R X 6	1°30'	9	85	150	10	
2JJTB 020 020 500	1R X 2	2°	2	50	90	6		2JJTB 060 020 600	3R X 6	2°	9	60	110	10	
2JJTB 020 030 300	1R X 2	3°	2	30	70	6		2JJTB 060 020 900	3R X 6	2°	9	90	150	12	
2JJTB 020 030 400	1R X 2	3°	2	40	80	6		2JJTB 060 030 290	3R X 6	3°	9	29	90	8	
2JJTB 020 030 500	1R X 2	3°	2	50	90	8		2JJTB 060 050 320	3R X 6	5°	9	32	110	10	
2JJTB 020 050 250	1R X 2	5°	2	25	60	6		2JJTB 080 010 500	4R X 8	1°	12	50	100	10	
2JJTB 020 050 380	1R X 2	5°	2	38	80	8		2JJTB 080 010 600	4R X 8	1°	12	60	110	10	
2JJTB 030 003 160	1.5R X 3	0°30'	3	16	60	6		2JJTB 080 010 800	4R X 8	1°	12	80	130	12	
2JJTB 030 003 200	1.5R X 3	0°30'	3	20	65	6		2JJTB 080 010 1000	4R X 8	1°	12	100	150	12	
2JJTB 030 003 300	1.5R X 3	0°30'	3	30	70	6		2JJTB 080 013 520	4R X 8	1°30'	12	52	110	10	
2JJTB 030 003 400	1.5R X 3	0°30'	3	40	80	6		2JJTB 080 013 890	4R X 8	1°30'	12	89	150	12	
2JJTB 030 003 500	1.5R X 3	0°30'	3	50	90	6		2JJTB 080 030 330	4R X 8	3°	12	33	100	10	
2JJTB 030 003 600	1.5R X 3	0°30'	3	60	100	6		2JJTB 100 010 600	5R X 10	1°	18	60	110	12	
2JJTB 030 010 160	1.5R X 3	1°	3	16	60	6		2JJTB 100 010 750	5R X 10	1°	18	75	130	12	
2JJTB 030 010 200	1.5R X 3	1°	3	20	65	6		2JJTB 100 013 540	5R X 10	1°30'	18	54	130	12	
2JJTB 030 010 300	1.5R X 3	1°	3	30	70	6		2JJTB 100 030 370	5R X 10	3°	18	37	110	12	
2JJTB 030 010 400	1.5R X 3	1°	3	40	80	6		2JJTB 120 013 850	6R X 12	1°30'	22	85	160	16	
2JJTB 030 010 500	1.5R X 3	1°	3	50	90	6		2JJTB 120 030 630	6R X 12	3°	22	63	130	16	
2JJTB 030 010 600	1.5R X 3	1°	3	60	100	6									
2JJTB 030 010 700	1.5R X 3	1°	3	70	110	6									
2JJTB 030 013 160	1.5R X 3	1°30'	3	16	60	6									
2JJTB 030 013 200	1.5R X 3	1°30'	3	20	65	6									
2JJTB 030 013 300	1.5R X 3	1°30'	3	30	70	6									
2JJTB 030 013 400	1.5R X 3	1°30'	3	40	80	6									
2JJTB 030 013 500	1.5R X 3	1°30'	3	50	90	6									
2JJTB 030 013 600	1.5R X 3	1°30'	3	60	100	6									
2JJTB 030 013 700	1.5R X 3	1°30'	3	70	120	8									

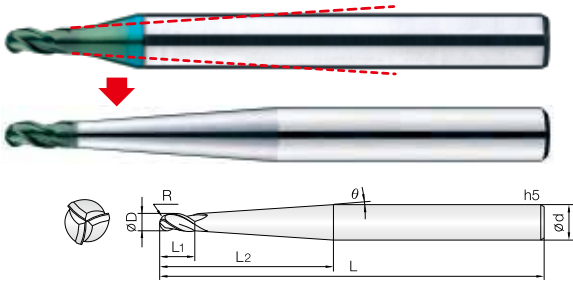

- 고경도강(HRc52~68), 프리하든강 계열의 고정밀 가공 엔드밀
- 깊은 홈 가공이 빈번해진 추세에 맞춰, 고객 요구에 빠르게 대응하는 맞춤제작 방식입니다. (최고 2일안에 납품가능)
- 고정밀 공차 적용으로 초정밀 가공에 적합합니다.
- 고객주문에 맞춰, 자사 재고품의 각도 및 유효길이를 재조정 가공합니다.
- 초미립자 초경합금(0.2µm)을 채택, 고속절삭시 뛰어난 성능을 발휘합니다.

- Endmills for pre-hardened and hardened steels(HRc52~68)
- Tailor-made special tools production for deep hole machining
- Suitable for ultra-precision machining by applying ultra-precision tolerances.
- With our STD stock the angle and effective length will be re-adjusted upon customers' required order spec
- Adoped ultra-fine grain cemented carbide (0.2µm) and shows excellent performance during high-speed cutting.

3

**UWC**  
초미립자

**TISIN-S**  
Coating

**R**  
±0.005

**R**  
±0.01

**30°**  
Helix Angle

**CUTTING DATA**

0.5 ~ 2.5R      3 ~ 6R      408P

Condition	D Size	D Tolerance
ØD ≠ Ød	Ø1 ~ 12	+0 ~ -0.01mm

단위 : mm

Order Number	날경 Diameter R × D	각도 Angle θ	날장 Length of cut L1	유효장 Effective Length L2	전장 Overall Length L	샤프트 Shank Dia d	비고
3JJTBS 010 060 S04	0.5R X 1	편이한 각도 편이한 날장 편이한 유효장 편이한 전장 편이한 샤프트 편이한 비고 Kindly request the desired angle	1	편이한 유효장 편이한 전장 편이한 샤프트 Kindly request the desired effective length	60	4	
3JJTBS 010 080 S04	0.5R X 1		1		80	4	
3JJTBS 010 090 S06	0.5R X 1		1		90	6	
3JJTBS 015 060 S04	0.75R X 1.5		1.5		60	4	
3JJTBS 015 080 S04	0.75R X 1.5		1.5		80	4	
3JJTBS 015 090 S06	0.75R X 1.5		1.5		90	6	
3JJTBS 020 070 S04	1R X 2		2		70	4	
3JJTBS 020 090 S04	1R X 2		2		90	4	
3JJTBS 020 090 S06	1R X 2		2		90	6	
3JJTBS 030 080 S06	1.5R X 3		3		80	6	
3JJTBS 030 100 S06	1.5R X 3		3		100	6	
3JJTBS 030 110 S08	1.5R X 3		3		110	8	
3JJTBS 040 080 S06	2R X 4		5		80	6	
3JJTBS 040 110 S06	2R X 4		5		110	6	
3JJTBS 040 120 S08	2R X 4		5		120	8	
3JJTBS 050 090 S08	2.5R X 5		7		90	8	
3JJTBS 050 120 S08	2.5R X 5		7		120	8	
3JJTBS 060 110 S08	3R X 6		9		110	8	
3JJTBS 060 150 S10	3R X 6		9		150	10	
3JJTBS 080 120 S10	4R X 8		12		120	10	
3JJTBS 080 160 S12	4R X 8	12	160	12			
3JJTBS 100 120 S12	5R X 10	15	120	12			
3JJTBS 100 160 S12	5R X 10	15	160	12			
3JJTBS 120 160 S16	6R X 12	18	160	16			
3JJTBS 120 200 S16	6R X 12	18	200	16			



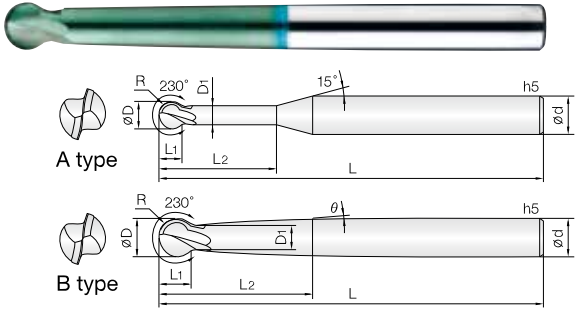

- 고경도강(HRc52~68), 프리하드강 계열의 고정밀 가공 엔드밀
  - 고품량 실리콘계 코팅(Si) 처리하여 내마모성이 우수합니다.
  - 230도 구형의 인선으로 광범위한 3D 가공이 가능합니다.
  - 유효장을 테이퍼 설계하여 깊은 홈 작업시 목부 파손 및 떨림을 최소화 하였습니다
  - 초미립자 초경합금(0.2µm)을 채택, 고속절삭시 뛰어난 성능을 발휘합니다.
- Endmills for pre-hardened and hardened steels(HRc52~68)
  - Good wear resistance by high quality Si-based PVD coating.
  - 230° degree ball shape for wide range 3D machining.
  - Minimize chattering and fracturing by taper designed flute.
  - Outstanding performance at high speed machining by ultra fine (0.2µm) WC grade.

2

UWC  
초미립자

TISIN-S  
Coating

R  
±0.005

R  
±0.01

15°  
Helix Angle

CUTTING  
DATA

0.25 ~ 2.5R    3 ~ 6R    410P

Condition	D Size	D Tolerance	Condition	D Size	D Tolerance
ØD ≠ Ød	Ø0.5 ~ 12	+0 ~ -0.01mm	ØD = Ød	Ø6 ~ 12	-0.005 ~ -0.015mm

단위 : mm

Order Number	날경 Diameter R × D	목경 Neck Diameter D1	날장 Length of cut L1	유효장 Effective Length L2	각도 Angle θ	전장 Overall Length L	타입 Type	샙크 Dia d	비고
New 2JJSP 005 010 S06	0.25R X 0.5	0.43	0.36	1	0°	55	A	6	
New 2JJSP 005 015 S06	0.25R X 0.5	0.43	0.36	1.5	0°	55	A	6	
New 2JJSP 005 020 S06	0.25R X 0.5	0.43	0.36	2	0°	55	A	6	
New 2JJSP 006 010 S06	0.3R X 0.6	0.52	0.43	1	0°	55	A	6	
New 2JJSP 006 020 S06	0.3R X 0.6	0.52	0.43	2	0°	55	A	6	
New 2JJSP 006 030 S06	0.3R X 0.6	0.52	0.43	3	0°	55	A	6	
New 2JJSP 008 020 S06	0.4R X 0.8	0.71	0.57	2	0°	55	A	6	
New 2JJSP 008 030 S06	0.4R X 0.8	0.71	0.57	3	0°	55	A	6	
New 2JJSP 008 040 S06	0.4R X 0.8	0.71	0.57	4	0°	55	A	6	
2JJSP 010 040 S06	0.5R X 1	0.91	0.7	4	0°	60	A	6	
2JJSP 010 060 S06	0.5R X 1	0.91	0.7	6	0°	60	A	6	
2JJSP 010 013 200	0.5R X 1	0.91	0.7	20	1°30'	80	B	6	
2JJSP 015 060 S06	0.75R X 1.5	1.36	1	6	0°	60	A	6	
2JJSP 015 080 S06	0.75R X 1.5	1.36	1	8	0°	60	A	6	
2JJSP 015 013 200	0.75R X 1.5	1.36	1	20	1°30'	80	B	6	
2JJSP 020 060 S06	1R X 2	1.8	1.4	6	0°	60	A	6	
2JJSP 020 100 S06	1R X 2	1.8	1.4	10	0°	60	A	6	
2JJSP 020 013 200	1R X 2	1.8	1.4	20	1°30'	80	B	6	
2JJSP 030 100 S06	1.5R X 3	2.7	2.1	10	0°	70	A	6	
2JJSP 030 150 S06	1.5R X 3	2.7	2.1	15	0°	70	A	6	
2JJSP 030 013 300	1.5R X 3	2.7	2.1	30	1°30'	80	B	6	
2JJSP 040 120 S06	2R X 4	3.6	2.8	12	0°	70	A	6	
2JJSP 040 200 S06	2R X 4	3.6	2.8	20	0°	70	A	6	
2JJSP 040 030 250	2R X 4	3.6	2.8	25	3°	80	B	6	
2JJSP 050 010 400	2.5R X 5	4.5	3.5	40	1°	90	B	6	
2JJSP 060 150 S06	3R X 6	5.4	4.2	15	0°	90	A	6	
2JJSP 060 300 S06	3R X 6	5.4	4.2	30	0°	90	A	6	
2JJSP 060 010 210	3R X 6	5.4	4.2	21	1°	100	B	6	
2JJSP 080 010 280	4R X 8	7.2	5.7	28	1°	100	B	8	
2JJSP 100 010 350	5R X 10	9	7.1	35	1°	110	B	10	
2JJSP 120 010 420	6R X 12	10.8	8.5	42	1°	120	B	12	

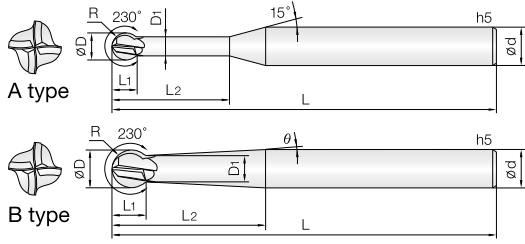

- 고경도강(HRc52~68), 프리하든강 계열의 고정밀 가공 엔드밀
- 고품질 실리콘계 코팅(Si) 처리하여 내마모성이 우수합니다.
- 230도 구형의 인선으로 광범위한 3D 가공이 가능합니다.
- 유효장을 테이퍼 설계하여 깊은 홈 작업시 목부 파손 및 떨림을 최소화 하였습니다.
- 초미립자 초경합금(0.2 $\mu$ m)을 채택, 고속절삭시 뛰어난 성능을 발휘합니다.

• Endmills for pre-hardened and hardened steels(HRc52~68)

- Good wear resistance by high quality Si-based PVD coating.
- 230° degree ball shape for wide range 3D machining.
- Minimize chattering and fracturing by taper designed flute.
- Outstanding performance at high speed machining by ultra fine (0.2 $\mu$ m) WC grade.

4

UWC  
초미립자

TISIN-S  
Coating

R  
±0.005

R  
±0.01

15°  
Helix Angle

CUTTING  
DATA

0.5 ~ 2.5R      3 ~ 6R      411P

Condition	D Size	D Tolerance	Condition	D Size	D Tolerance
∅D ≠ ∅d	∅1 ~ 12	+0 ~ -0.01mm	∅D = ∅d	∅6 ~ 12	-0.005 ~ -0.015mm

단위 : mm

Order Number	날경 Diameter R x D	목경 Neck Diameter D1	날장 Length of cut L1	유효장 Effective Length L2	각도 Angle θ	전장 Overall Length L	타입 Type	샤희크 Shank Dia d	비고
4JJSP 010 040 S06	0.5R X 1	0.91	0.7	4	0°	60	A	6	
4JJSP 010 060 S06	0.5R X 1	0.91	0.7	6	0°	60	A	6	
4JJSP 010 013 200	0.5R X 1	0.91	0.7	20	1°30'	80	B	6	
4JJSP 015 060 S06	0.75R X 1.5	1.36	1	6	0°	60	A	6	
4JJSP 015 080 S06	0.75R X 1.5	1.36	1	8	0°	60	A	6	
4JJSP 015 013 200	0.75R X 1.5	1.36	1	20	1°30'	80	B	6	
4JJSP 020 060 S06	1R X 2	1.8	1.4	6	0°	60	A	6	
4JJSP 020 100 S06	1R X 2	1.8	1.4	10	0°	60	A	6	
4JJSP 020 013 200	1R X 2	1.8	1.4	20	1°30'	80	B	6	
4JJSP 030 100 S06	1.5R X 3	2.7	2.1	10	0°	70	A	6	
4JJSP 030 150 S06	1.5R X 3	2.7	2.1	15	0°	70	A	6	
4JJSP 030 013 300	1.5R X 3	2.7	2.1	30	1°30'	80	B	6	
4JJSP 040 120 S06	2R X 4	3.6	2.8	12	0°	70	A	6	
4JJSP 040 200 S06	2R X 4	3.6	2.8	20	0°	70	A	6	
4JJSP 040 030 250	2R X 4	3.6	2.8	25	3°	80	B	6	
4JJSP 050 010 400	2.5R X 5	4.5	3.5	40	1°	90	B	6	
4JJSP 060 150 S06	3R X 6	5.4	4.2	15	0°	90	A	6	
4JJSP 060 300 S06	3R X 6	5.4	4.2	30	0°	90	A	6	
4JJSP 060 010 210	3R X 6	5.4	4.2	21	1°	100	B	6	
4JJSP 080 010 280	4R X 8	7.2	5.7	28	1°	100	B	8	
4JJSP 100 010 350	5R X 10	9	7.1	35	1°	110	B	10	
4JJSP 120 010 420	6R X 12	10.8	8.5	42	1°	120	B	12	

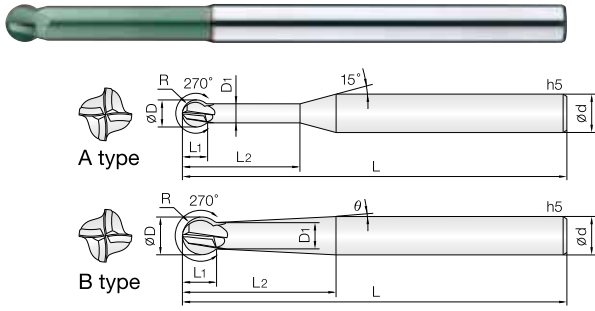

- 고경도강(HRc52~68), 프리하든강 계열의 고정밀 가공 엔드밀
- 고품량 실리콘계 코팅(Si) 처리하여 내마모성이 우수합니다.
- 270도 구형의 인선으로 광범위한 3D 가공이 가능합니다.
- 유효장을 테이퍼 설계하여 깊은 홈 작업시 목부 파손 및 떨림을 최소화 하였습니다.
- 초미립자 초경합금(0.2 $\mu$ m)을 채택, 고속절삭시 뛰어난 성능을 발휘합니다.
- Endmills for pre-hardened and hardened steels(HRc52~68)
- Good wear resistance by high quality Si-based PVD coating.
- 270° degree ball shape for wide range 3D machining.
- Minimize chattering and fracturing by taper designed flute.
- Outstanding performance at high speed machining by ultra fine (0.2 $\mu$ m) WC grade.

4 UWC 초미립자 TISIN-S Coating R ±0.005 R ±0.01 15° Helix Angle CUTTING DATA 411P

Condition	D Size	D Tolerance	Condition	D Size	D Tolerance
ØD ≠ Ød	Ø1 ~ 12	+0 ~ -0.01mm	ØD = Ød	Ø6 ~ 12	-0.005 ~ -0.015mm

단위 : mm

Order Number	날경 Diameter R × D	목경 Neck Diameter D1	날장 Length of cut L1	유효장 Effective Length L2	각도 Angle $\theta$	전장 Overall Length L	타입 Type	샙크 Shank Dia d	비고
4JJSPM 010 040 S06	0.5R X 1	0.7	0.8	4	0°	60	A	6	
4JJSPM 010 060 S06	0.5R X 1	0.7	0.8	6	0°	60	A	6	
4JJSPM 010 013 200	0.5R X 1	0.7	0.8	20	1°30'	80	B	6	
4JJSPM 015 060 S06	0.75R X 1.5	1	1.2	6	0°	60	A	6	
4JJSPM 015 080 S06	0.75R X 1.5	1	1.2	8	0°	60	A	6	
4JJSPM 015 013 200	0.75R X 1.5	1	1.2	20	1°30'	80	B	6	
4JJSPM 020 060 S06	1R X 2	1.4	1.7	6	0°	60	A	6	
4JJSPM 020 100 S06	1R X 2	1.4	1.7	10	0°	60	A	6	
4JJSPM 020 013 200	1R X 2	1.4	1.7	20	1°30'	80	B	6	
4JJSPM 030 100 S06	1.5R X 3	2.1	2.5	10	0°	70	A	6	
4JJSPM 030 150 S06	1.5R X 3	2.1	2.5	15	0°	70	A	6	
4JJSPM 030 013 300	1.5R X 3	2.1	2.5	30	1°30'	80	B	6	
4JJSPM 040120 S06	2R X 4	2.8	3.4	12	0°	70	A	6	
4JJSPM 040 200 S06	2R X 4	2.8	3.4	20	0°	70	A	6	
4JJSPM 040 030 250	2R X 4	2.8	3.4	25	3°	80	B	6	
4JJSPM 050 010 400	2.5R X 5	3.5	4.2	40	1°	90	B	6	
4JJSPM 060 150 S06	3R X 6	4.2	5.1	15	0°	90	A	6	
4JJSPM 060 300 S06	3R X 6	4.2	5.1	30	0°	90	A	6	
4JJSPM 060 010 210	3R X 6	4.2	5.1	21	1°	100	B	6	
4JJSPM 080 010 280	4R X 8	5.6	6.8	28	1°	100	B	8	
4JJSPM 100 010 350	5R X 10	7	8.5	35	1°	110	B	10	
4JJSPM 120 010 420	6R X 12	8.5	10	42	1°	120	B	12	

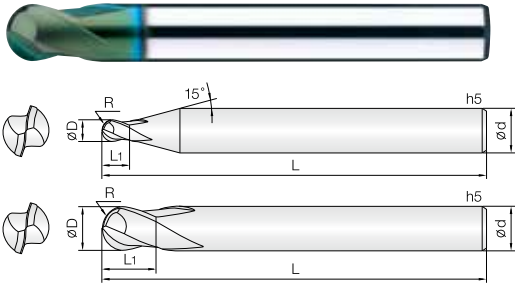

- 고경도강(HRc52~68), 프리하든강 계열의 고정밀 가공 엔드밀
- 고품량 실리콘계 코팅(Si) 처리하여 내마모성이 우수합니다.
- 고정밀 공차 적용으로 초정밀 가공에 적합합니다.
- 짧은 전장을 채택하여 열박음척 사용이 용이합니다.
- 날부인선의 조도가 뛰어나 피삭재의 면조도가 우수합니다.
- 초미립자 초경합금(0.2 $\mu$ m)을 채택, 고속절삭시 뛰어난 성능을 발휘합니다.

#### • Endmills for pre-hardened and hardened steels(HRc52~68)

- Good wear resistance by high quality Si-based PVD coating.
- High precise edge tolerance.
- Short overall length for easy use with shirinking chuck.
- Very nice work surface finish.
- Outstanding performance at high speed machining by ultra fine (0.2 $\mu$ m) WC grade.

2

UWC  
초미립자

TISIN-S  
Coating

R  
 $\pm 0.005$

R  
 $\pm 0.01$

30°  
Helix Angle

CUTTING  
DATA

0.05 ~ 2.5R    3 ~ 6R    411P

Condition	D Size	D Tolerance	Condition	D Size	D Tolerance
$\varnothing D \neq \varnothing d$	$\varnothing 0.1 \sim 0.15$	+0 ~ -0.005mm	$\varnothing D = \varnothing d$	$\varnothing 4 \sim 12$	-0.005 ~ -0.015mm
	$\varnothing 0.2 \sim 12$	+0 ~ -0.01mm			

단위 : mm

Order Number	날경 Diameter R x D	날장 Length of cut L1	전장 Overall Length L	생크 Shank Dia d	비고	Order Number	날경 Diameter R x D	날장 Length of cut L1	전장 Overall Length L	생크 Shank Dia d	비고
2JJSB 001 001 S04	0.05R X 0.1	0.1	40	4		2JJSB 120 120 060	6R X 12	12	60	12	
2JJSB 001 0015 S04	0.05R X 0.1	0.15	40	4		2JJSB 120 150 070	6R X 12	15	70	12	
2JJSB 0015 0015 S04	0.075R X 0.15	0.15	40	4							
2JJSB 0015 002 S04	0.075R X 0.15	0.2	40	4							
2JJSB 002 002 S04	0.1R X 0.2	0.2	40	4							
2JJSB 002 003 S04	0.1R X 0.2	0.3	40	4							
2JJSB 003 003 S04	0.15R X 0.3	0.3	40	4							
2JJSB 003 0045 S04	0.15R X 0.3	0.45	40	4							
2JJSB 004 004 S04	0.2R X 0.4	0.4	40	4							
2JJSB 004 006 S04	0.2R X 0.4	0.6	40	4							
2JJSB 005 005 S04	0.25R X 0.5	0.5	40	4							
2JJSB 005 0075 S04	0.25R X 0.5	0.75	40	4							
2JJSB 006 006 S04	0.3R X 0.6	0.6	40	4							
2JJSB 006 009 S04	0.3R X 0.6	0.9	40	4							
2JJSB 007 007 S04	0.35R X 0.7	0.7	40	4							
2JJSB 007 010 S04	0.35R X 0.7	1	40	4							
2JJSB 008 008 S04	0.4R X 0.8	0.8	40	4							
2JJSB 008 012 S04	0.4R X 0.8	1.2	40	4							
2JJSB 009 009 S04	0.45R X 0.9	0.9	40	4							
2JJSB 009 013 S04	0.45R X 0.9	1.3	40	4							
2JJSB 010 010 S04	0.5R X 1	1	40	4							
2JJSB 010 010 S06	0.5R X 1	1	40	6							
2JJSB 010 015 S04	0.5R X 1	1.5	40	4							
2JJSB 010 015 S06	0.5R X 1	1.5	40	6							
2JJSB 012 012 S04	0.6R X 1.2	1.2	40	4							
2JJSB 015 015 S04	0.75R X 1.5	1.5	40	4							
2JJSB 015 015 S06	0.75R X 1.5	1.5	40	6							
2JJSB 015 023 S04	0.75R X 1.5	2.3	40	4							
2JJSB 015 023 S06	0.75R X 1.5	2.3	40	6							
2JJSB 020 020 S04	1R X 2	2	45	4							
2JJSB 020 020 S06	1R X 2	2	45	6							
2JJSB 020 030 S04	1R X 2	3	45	4							
2JJSB 020 030 S06	1R X 2	3	45	6							
2JJSB 025 025 S06	1.25R X 2.5	2.5	45	6							
2JJSB 030 030 S04	1.5R X 3	3	45	4							
2JJSB 030 030 S06	1.5R X 3	3	45	6							
2JJSB 030 045 S04	1.5R X 3	4.5	45	4							
2JJSB 030 045 S06	1.5R X 3	4.5	45	6							
2JJSB 040 040 S04	2R X 4	4	45	4							
2JJSB 040 040 S06	2R X 4	4	45	6							
2JJSB 040 060 S04	2R X 4	6	45	4							
2JJSB 040 060 S06	2R X 4	6	45	6							
2JJSB 050 050 S06	2.5R X 5	5	50	6							
2JJSB 050 075 S06	2.5R X 5	7.5	50	6							
2JJSB 060 060 050	3R X 6	6	50	6							
2JJSB 060 080 055	3R X 6	8	55	6							
2JJSB 080 080 050	4R X 8	8	50	8							
2JJSB 080 110 060	4R X 8	11	60	8							
2JJSB 100 100 060	5R X 10	10	60	10							
2JJSB 100 130 070	5R X 10	13	70	10							

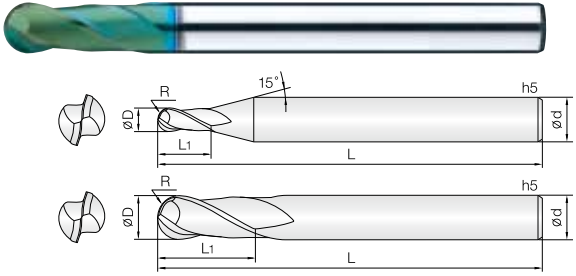

- 고경도강(HRc52~68), 프리하든강 계열의 고정밀 가공 엔드밀
  - 고품질 실리콘계 코팅 (Si) 처리하여 내마모성이 우수합니다.
  - 고정밀 공차 적용으로 초정밀 가공에 적합합니다.
  - 날부인선의 조도가 뛰어나 피삭재의 면조도가 우수합니다.
  - 초미립자 초경합금(0.2μm)을 채택, 고속절삭시 뛰어난 성능을 발휘합니다.
- Endmills for pre-hardened and hardened steels(HRc52~68)
  - Good wear resistance by high quality Si-based PVD coating.
  - High precise edge tolerance.
  - Excellent surface finish.
  - Very nice work surface finish.
  - Outstanding performance at high speed machining by ultra fine (0.2μm) WC grade.

2

UWC  
초미립자

TISIN-S  
Coating

R

R

R

30°  
Helix Angle

CUTTING  
DATA

0.05 ~ 2.75R
3 ~ 6R
7R
411P

Condition	D Size		D Tolerance	Condition	D Size		D Tolerance
	φD ≠ φd	φ0.1 ~ 0.15			+0 ~ -0.005mm	φD = φd	φ3 ~ 12
φ0.2 ~ 14			+0 ~ -0.01mm	φ14			-0.01 ~ -0.02mm

단위 : mm

Order Number	날경 Diameter R × D	날장 Length of cut L1	전장 Overall Length L	생크 Shank Dia d	비고	Order Number	날경 Diameter R × D	날장 Length of cut L1	전장 Overall Length L	생크 Shank Dia d	비고
2JJB 001 002 S04	0.05R X 0.1	0.2	40	4		2JJB 140 240 110	7R X 14	24	110	14	
2JJB 0015 003 S04	0.075R X 0.15	0.3	40	4							
2JJB 002 004 S04	0.1R X 0.2	0.4	40	4							
2JJB 003 006 S04	0.15R X 0.3	0.6	40	4							
2JJB 004 008 S04	0.2R X 0.4	0.8	40	4							
2JJB 005 010 S04	0.25R X 0.5	1	45	4							
2JJB 006 012 S04	0.3R X 0.6	1.2	45	4							
2JJB 007 015 S04	0.35R X 0.7	1.5	45	4							
2JJB 008 020 S04	0.4R X 0.8	2	45	4							
2JJB 009 020 S04	0.45R X 0.9	2	45	4							
2JJB 010 025 S03	0.5R X 1	2.5	50	3							
2JJB 010 025 S04	0.5R X 1	2.5	50	4							
2JJB 010 025 S06	0.5R X 1	2.5	50	6							
2JJB 010 025 070	0.5R X 1	2.5	70	6							
2JJB 012 030 S03	0.6R X 1.2	3	50	3							
2JJB 012 030 S04	0.6R X 1.2	3	50	4							
2JJB 015 040 S03	0.75R X 1.5	4	50	3							
2JJB 015 040 S04	0.75R X 1.5	4	50	4							
2JJB 015 040 S06	0.75R X 1.5	4	50	6							
2JJB 015 040 070	0.75R X 1.5	4	70	6							
2JJB 020 050 S03	1R X 2	5	50	3							
2JJB 020 050 S04	1R X 2	5	50	4							
2JJB 020 050 S06	1R X 2	5	50	6							
2JJB 020 050 075	1R X 2	5	75	6							
2JJB 025 060 S03	1.25R X 2.5	6	50	3							
2JJB 025 060 S04	1.25R X 2.5	6	50	4							
2JJB 025 060 S06	1.25R X 2.5	6	75	6							
2JJB 030 080 S03	1.5R X 3	8	50	3							
2JJB 030 080 S04	1.5R X 3	8	50	4							
2JJB 030 080 S06	1.5R X 3	8	60	6							
2JJB 030 080 080	1.5R X 3	8	80	6							
2JJB 035 080 S06	1.75R X 3.5	8	60	6							
2JJB 040 080 S04	2R X 4	8	60	4							
2JJB 040 080 080	2R X 4	8	80	4							
2JJB 040 080 S06	2R X 4	8	70	6							
2JJB 040 080 090	2R X 4	8	90	6							
2JJB 045 080 S06	2.25R X 4.5	8	70	6							
2JJB 050 100 S06	2.5R X 5	10	75	6							
2JJB 055 100 S06	2.75R X 5.5	10	75	6							
2JJB 060 100 060	3R X 6	10	60	6							
2JJB 060 120 080	3R X 6	12	80	6							
2JJB 060 120 090	3R X 6	12	90	6							
2JJB 070 140 S08	3.5R X 7	14	80	8							
2JJB 080 120 060	4R X 8	12	60	8							
2JJB 080 140 090	4R X 8	14	90	8							
2JJB 080 140 100	4R X 8	14	100	8							
2JJB 100 150 070	5R X 10	15	70	10							
2JJB 100 180 100	5R X 10	18	100	10							
2JJB 120 180 075	6R X 12	18	75	12							
2JJB 120 220 110	6R X 12	22	110	12							



### 3 Flutes JJ Ball End Mills for Hardened Steels

## 3날 고경도재 가공용 제이제이 볼 엔드밀

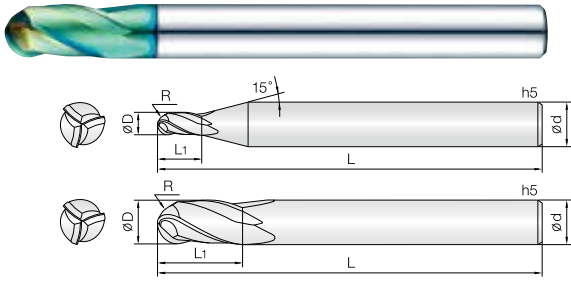

- 고경도강(HRC52~68), 프리하든강 계열의 고정밀 가공 엔드밀
- 고품량 실리콘계 코팅(Si) 처리하여 내마모성이 우수합니다.
- 고정밀 공차 적용으로 초정밀 가공에 적합합니다.
- 3날 볼타입 적용으로 고속, 고이송 작업이 가능합니다.
- 초미립자 초경합금(0.2μm)을 채택, 고속절삭시 뛰어난 성능을 발휘합니다.

### Endmills for pre-hardened and hardened steels(HRC52~68)

- Good wear resistance by high quality Si-based PVD coating.
- High precise edge tolerance.
- Three flutes ball edge design for high speed, feed condition.
- Outstanding performance at high speed machining by ultra fine (0.2μm) WC grade.

0.5 ~ 2.5R    3 ~ 6R    411P

Condition	D Size	D Tolerance	Condition	D Size	D Tolerance
∅D ≠ ∅d	∅1 ~ 12	+0 ~ -0.01mm	∅D = ∅d	∅4 ~ 12	-0.005 ~ -0.015mm

단위 : mm

Order Number	날경 Diameter R × D	날장 Length of cut L1	전장 Overall Length L	샥크 Shank Dia d	비고	Order Number	날경 Diameter R × D	날장 Length of cut L1	전장 Overall Length L	샥크 Shank Dia d	비고
3JJB 010 025 S04	0.5R X 1	2.5	50	4		3JJB 060 120 S06	3R X 6	12	80	6	
3JJB 012 030 S04	0.6R X 1.2	3	50	4		3JJB 060 120 120	3R X 6	12	120	6	
3JJB 015 040 S04	0.75R X 1.5	4	50	4		3JJB 080 140 S08	4R X 8	14	90	8	
3JJB 020 050 S06	1R X 2	5	50	6		3JJB 080 140 150	4R X 8	14	150	8	
3JJB 030 080 S06	1.5R X 3	8	65	6		3JJB 100 180 S10	5R X 10	18	100	10	
3JJB 040 080 S04	2R X 4	8	60	4		3JJB 100 180 150	5R X 10	18	150	10	
3JJB 040 080 S06	2R X 4	8	70	6		3JJB 120 220 S12	6R X 12	22	110	12	
3JJB 050 100 S06	2.5R X 5	10	75	6		3JJB 120 220 150	6R X 12	22	150	12	



### 4 Flutes JJ Short Length Ball End Mills for Hardened Steels

## 4날 고경도재 가공용 제이제이 짧은 길이 볼 엔드밀

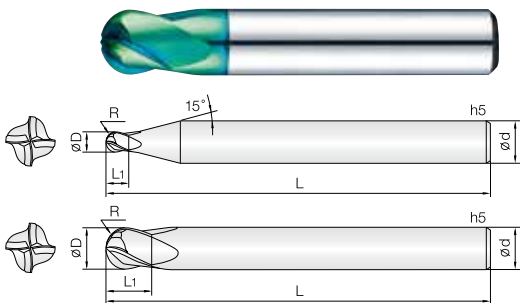

- 고경도강(HRC52~68), 프리하든강 계열의 고정밀 가공 엔드밀
- 고품량 실리콘계 코팅(Si) 처리하여 내마모성이 우수합니다.
- 고정밀 공차 적용으로 초정밀 가공에 적합합니다.
- 짧은 전장을 채택하여 열박음척 사용이 용이합니다.
- 4날 볼타입 적용으로 고속, 고이송 작업이 가능합니다.
- 초미립자 초경합금(0.2μm)을 채택, 고속절삭시 뛰어난 성능을 발휘합니다.

### Endmills for pre-hardened and hardened steels(HRC52~68)

- Good wear resistance by high quality Si-based PVD coating.
- High precise edge tolerance.
- Short overall length for easy use with shirking chuck.
- Four flutes ball edge design for high speed, feed condition.
- Outstanding performance at high speed machining by ultra fine (0.2μm) WC grade.

0.5 ~ 2.5R    3 ~ 6R    411P

Condition	D Size	D Tolerance	Condition	D Size	D Tolerance
∅D ≠ ∅d	∅1 ~ 12	+0 ~ -0.01mm	∅D = ∅d	∅4 ~ 12	-0.005 ~ -0.015mm

단위 : mm

Order Number	날경 Diameter R × D	날장 Length of cut L1	전장 Overall Length L	샥크 Shank Dia d	비고	Order Number	날경 Diameter R × D	날장 Length of cut L1	전장 Overall Length L	샥크 Shank Dia d	비고
4JJSB 010 012 S04	0.5R X 1	1.2	40	4							
4JJSB 012 015 S04	0.6R X 1.2	1.5	40	4							
4JJSB 015 018 S04	0.75R X 1.5	1.8	40	4							
4JJSB 020 024 S04	1R X 2	2.4	40	4							
4JJSB 025 030 S04	1.25R X 2.5	3	45	4							
4JJSB 030 036 S06	1.5R X 3	3.6	45	6							
4JJSB 040 050 S04	2R X 4	5	45	4							
4JJSB 040 050 S06	2R X 4	5	45	6							
4JJSB 050 060 S06	2.5R X 5	6	50	6							
4JJSB 060 070 S06	3R X 6	7	50	6							
4JJSB 060 070 060	3R X 6	7	60	6							
4JJSB 080 080 S08	4R X 8	8	60	8							
4JJSB 100 100 S10	5R X 10	10	60	10							
4JJSB 120 120 S12	6R X 12	12	75	12							

## 4날 고경도재 가공용 제이제이 볼 엔드밀

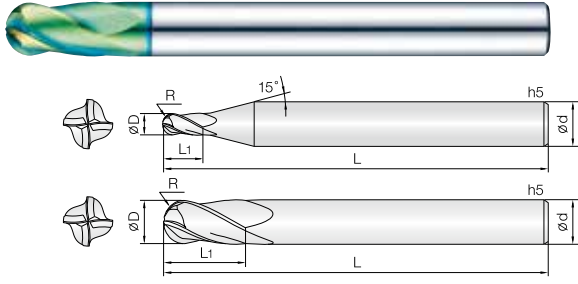

- 고경도강(HRc52~68), 프리하든강 계열의 고정밀 가공 엔드밀
- 고품량 실리콘계 코팅 (Si) 처리하여 내마모성이 우수합니다.
- 고정밀 공차 적용으로 초정밀 가공에 적합합니다.
- 4날 볼타입 적용으로 고속, 고이송 작업이 가능합니다.
- 항절력이 높은 미립자 초경합금 (0.5µm)을 채택, 엔드밀의 파손을 최소화 하였습니다.

### • Endmill for pre-hardened and hardened steels (HRc52~68)

- Good wear resistance by high quality Si-based PVD coating.
- High precise edge tolerance.
- Four flutes ball edge design for high speed, feed condition.
- Minimizing fracturing by high TRS fine (0.5µm) WC grade.

<b>4</b> 미립자	<b>WC</b> 미립자	<b>TISIN-S</b> Coating	<b>R</b> ±0.005	<b>R</b> ±0.01	<b>R</b> ±0.015	<b>30°</b> Helix Angle	<b>CUTTING DATA</b> 411P
			0.5 ~ 2.5R	3 ~ 6R	7 ~ 10R		

Condition	D Size	D Tolerance
ØD ≠ Ød	Ø1 ~ 20	+0 ~ -0.01mm

Condition	D Size	D Tolerance
ØD = Ød	Ø4 ~ 12	-0.005 ~ -0.015mm
	Ø14 ~ 20	-0.01 ~ -0.02mm

단위 : mm

Order Number	날경 Diameter R x D	날장 Length of cut L1	전장 Overall Length L	생크 Shank Dia d	비고
4JJB 010 025 S06	0.5R X 1	2.5	50	6	
4JJB 010 025 080	0.5R X 1	2.5	80	6	
4JJB 012 030 S06	0.6R X 1.2	3	50	6	
4JJB 015 040 S06	0.75R X 1.5	4	50	6	
4JJB 015 040 080	0.75R X 1.5	4	80	6	
4JJB 020 050 S06	1R X 2	5	50	6	
4JJB 020 050 080	1R X 2	5	80	6	
4JJB 025 070 S06	1.25R X 2.5	7	50	6	
4JJB 025 070 080	1.25R X 2.5	7	80	6	
4JJB 030 080 S06	1.5R X 3	8	60	6	
4JJB 030 080 090	1.5R X 3	8	90	6	
4JJB 040 080 S04	2R X 4	8	60	4	
4JJB 040 080 090	2R X 4	8	90	4	
4JJB 040 080 S06	2R X 4	8	70	6	
4JJB 040 080 100	2R X 4	8	100	6	
4JJB 050 100 S06	2.5R X 5	10	80	6	
4JJB 050 100 110	2.5R X 5	10	110	6	
4JJB 060 120 S06	3R X 6	12	90	6	
4JJB 060 120 110	3R X 6	12	110	6	
4JJB 080 140 S08	4R X 8	14	100	8	
4JJB 080 140 150	4R X 8	14	150	8	
4JJB 100 180 S10	5R X 10	18	100	10	
4JJB 100 180 150	5R X 10	18	150	10	
4JJB 120 220 S12	6R X 12	22	110	12	
4JJB 120 220 150	6R X 12	22	150	12	
4JJB 140 240 110	7R X 14	24	110	14	
4JJB 160 300 S16	8R X 16	30	130	16	
4JJB 160 300 160	8R X 16	30	160	16	
4JJB 200 400 S20	10R X 20	40	160	20	
4JJB 200 400 200	10R X 20	40	200	20	

Order Number	날경 Diameter R x D	날장 Length of cut L1	전장 Overall Length L	생크 Shank Dia d	비고

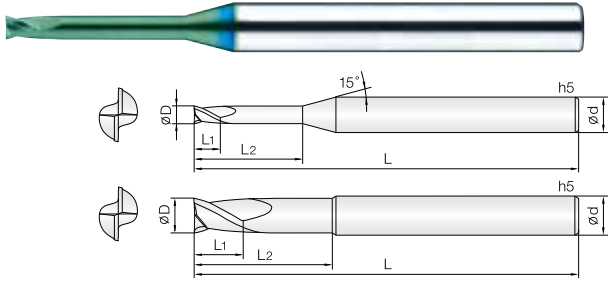

- 고경도강(HRc52~68), 프리하드강 계열의 고정밀 가공 엔드밀
- 고품량 실리콘계 코팅(Si) 처리하여 내마모성이 우수합니다.
- 고정밀 공차 적용으로 초정밀 가공에 적합합니다.
- 인선부 강성을 보강하여 날부치핑을 최소화 하였습니다.
- 초미립자 초경합금(0.2 $\mu$ m)을 채택, 고속절삭시 뛰어난 성능을 발휘합니다.

#### • Endmills for pre-hardened and hardened steels(HRc52~68)

- Good wear resistance by high quality Si-based PVD coating.
- High precise edge tolerance.
- Reinforced edge design for preventing edge chipping.
- Outstanding performance at high speed machining by ultra fine (0.2 $\mu$ m) WC grade.



Shield Edge 412P

Condition	D Size	D Tolerance	Condition	D Size	D Tolerance
øD ≠ ød	ø0.1 ~ 0.15	+0 ~ -0.005mm	øD = ød	ø6	-0.005 ~ -0.015mm
	ø0.2 ~ 6	+0 ~ -0.01mm		ø8 ~ 12	-0.01 ~ -0.025mm
	ø8 ~ 12	+0 ~ -0.015mm			

단위 : mm

Order Number	날경 Diameter D	날장 Length of cut L1	유효장 Effective Length L2	전장 Overall Length L	생크 Shank Dia d	비고	Order Number	날경 Diameter D	날장 Length of cut L1	유효장 Effective Length L2	전장 Overall Length L	생크 Shank Dia d	비고
2JJRE 001 003 S04	0.1	0.15	0.3	40	4		2JJRE 005 140 S04	0.5	0.5	14	45	4	
2JJRE 001 005 S04	0.1	0.15	0.5	40	4		2JJRE 005 160 S04	0.5	0.5	16	45	4	
2JJRE 0015 003 S04	0.15	0.15	0.3	40	4		2JJRE 006 010 S04	0.6	0.6	1	40	4	
2JJRE 0015 005 S04	0.15	0.15	0.5	40	4		2JJRE 006 020 S04	0.6	0.6	2	40	4	
2JJRE 0015 0075 S04	0.15	0.15	0.75	40	4		2JJRE 006 030 S04	0.6	0.6	3	40	4	
2JJRE 0015 010 S04	0.15	0.15	1	40	4		2JJRE 006 040 S04	0.6	0.6	4	40	4	
2JJRE 002 005 S04	0.2	0.2	0.5	40	4		2JJRE 006 050 S04	0.6	0.6	5	40	4	
2JJRE 002 010 S04	0.2	0.2	1	40	4		2JJRE 006 060 S04	0.6	0.6	6	40	4	
2JJRE 002 015 S04	0.2	0.2	1.5	40	4		2JJRE 006 080 S04	0.6	0.6	8	45	4	
2JJRE 002 020 S04	0.2	0.2	2	40	4		2JJRE 006 100 S04	0.6	0.6	10	45	4	
2JJRE 002 025 S04	0.2	0.2	2.5	40	4		2JJRE 006 120 S04	0.6	0.6	12	45	4	
2JJRE 002 030 S04	0.2	0.2	3	40	4		2JJRE 006 140 S04	0.6	0.6	14	45	4	
2JJRE 0025 005 S04	0.25	0.25	0.5	40	4		2JJRE 006 160 S04	0.6	0.6	16	45	4	
2JJRE 0025 010 S04	0.25	0.25	1	40	4		2JJRE 006 180 S04	0.6	0.6	18	50	4	
2JJRE 0025 015 S04	0.25	0.25	1.5	40	4		2JJRE 007 020 S04	0.7	0.7	2	40	4	
2JJRE 0025 020 S04	0.25	0.25	2	40	4		2JJRE 007 040 S04	0.7	0.7	4	40	4	
2JJRE 0025 025 S04	0.25	0.25	2.5	40	4		2JJRE 007 060 S04	0.7	0.7	6	40	4	
2JJRE 0025 030 S04	0.25	0.25	3	40	4		2JJRE 007 080 S04	0.7	0.7	8	45	4	
2JJRE 003 010 S04	0.3	0.3	1	40	4		2JJRE 007 100 S04	0.7	0.7	10	45	4	
2JJRE 003 015 S04	0.3	0.3	1.5	40	4		2JJRE 007 120 S04	0.7	0.7	12	45	4	
2JJRE 003 020 S04	0.3	0.3	2	40	4		2JJRE 007 140 S04	0.7	0.7	14	45	4	
2JJRE 003 025 S04	0.3	0.3	2.5	40	4		2JJRE 007 160 S04	0.7	0.7	16	45	4	
2JJRE 003 030 S04	0.3	0.3	3	40	4		2JJRE 008 010 S04	0.8	0.8	1	40	4	
2JJRE 003 035 S04	0.3	0.3	3.5	40	4		2JJRE 008 020 S04	0.8	0.8	2	40	4	
2JJRE 003 040 S04	0.3	0.3	4	40	4		2JJRE 008 030 S04	0.8	0.8	3	40	4	
2JJRE 003 050 S04	0.3	0.3	5	40	4		2JJRE 008 040 S04	0.8	0.8	4	40	4	
2JJRE 003 060 S04	0.3	0.3	6	40	4		2JJRE 008 050 S04	0.8	0.8	5	40	4	
2JJRE 003 070 S04	0.3	0.3	7	40	4		2JJRE 008 060 S04	0.8	0.8	6	40	4	
2JJRE 003 080 S04	0.3	0.3	8	40	4		2JJRE 008 080 S04	0.8	0.8	8	45	4	
2JJRE 004 010 S04	0.4	0.4	1	40	4		2JJRE 008 100 S04	0.8	0.8	10	45	4	
2JJRE 004 015 S04	0.4	0.4	1.5	40	4		2JJRE 008 120 S04	0.8	0.8	12	45	4	
2JJRE 004 020 S04	0.4	0.4	2	40	4		2JJRE 008 140 S04	0.8	0.8	14	45	4	
2JJRE 004 025 S04	0.4	0.4	2.5	40	4		2JJRE 008 160 S04	0.8	0.8	16	45	4	
2JJRE 004 030 S04	0.4	0.4	3	40	4		2JJRE 008 180 S04	0.8	0.8	18	50	4	
2JJRE 004 035 S04	0.4	0.4	3.5	40	4		2JJRE 008 200 S04	0.8	0.8	20	50	4	
2JJRE 004 040 S04	0.4	0.4	4	40	4		2JJRE 009 040 S04	0.9	0.9	4	40	4	
2JJRE 004 050 S04	0.4	0.4	5	40	4		2JJRE 009 060 S04	0.9	0.9	6	40	4	
2JJRE 004 060 S04	0.4	0.4	6	40	4		2JJRE 009 080 S04	0.9	0.9	8	45	4	
2JJRE 004 080 S04	0.4	0.4	8	40	4		2JJRE 009 100 S04	0.9	0.9	10	45	4	
2JJRE 004 100 S04	0.4	0.4	10	45	4		2JJRE 010 020 S04	1	1	2	45	4	
2JJRE 004 120 S04	0.4	0.4	12	45	4		2JJRE 010 030 S04	1	1	3	45	4	
2JJRE 005 010 S04	0.5	0.5	1	40	4		2JJRE 010 040 S04	1	1	4	45	4	
2JJRE 005 020 S04	0.5	0.5	2	40	4		2JJRE 010 050 S04	1	1	5	45	4	
2JJRE 005 030 S04	0.5	0.5	3	40	4		2JJRE 010 060 S04	1	1	6	45	4	
2JJRE 005 040 S04	0.5	0.5	4	40	4		2JJRE 010 080 S04	1	1	8	45	4	
2JJRE 005 050 S04	0.5	0.5	5	40	4		2JJRE 010 100 S04	1	1	10	45	4	
2JJRE 005 060 S04	0.5	0.5	6	40	4		2JJRE 010 120 S04	1	1	12	50	4	
2JJRE 005 080 S04	0.5	0.5	8	45	4		2JJRE 010 140 S04	1	1	14	50	4	
2JJRE 005 100 S04	0.5	0.5	10	45	4		2JJRE 010 160 S04	1	1	16	50	4	
2JJRE 005 120 S04	0.5	0.5	12	45	4		2JJRE 010 180 S04	1	1	18	50	4	



단위 : mm

Order Number	날경 Diameter D	날장 Length of cut L1	유효장 Effective Length L2	전장 Overall Length L	샙크 Dia d	비고	Order Number	날경 Diameter D	날장 Length of cut L1	유효장 Effective Length L2	전장 Overall Length L	샙크 Dia d	비고
2JJRE 010 200 S04	1	1	20	50	4		2JJRE 025 350 S04	2.5	2.5	35	70	4	
2JJRE 010 220 S04	1	1	22	60	4		2JJRE 025 400 S04	2.5	2.5	40	80	4	
2JJRE 010 250 S04	1	1	25	60	4		2JJRE 025 450 S04	2.5	2.5	45	90	4	
2JJRE 010 300 S04	1	1	30	70	4		2JJRE 025 500 S04	2.5	2.5	50	90	4	
2JJRE 012 040 S04	1.2	1.2	4	45	4		2JJRE 030 060 S06	3	3	6	45	6	
2JJRE 012 060 S04	1.2	1.2	6	45	4		2JJRE 030 080 S06	3	3	8	45	6	
2JJRE 012 080 S04	1.2	1.2	8	45	4		2JJRE 030 100 S06	3	3	10	50	6	
2JJRE 012 100 S04	1.2	1.2	10	45	4		2JJRE 030 120 S06	3	3	12	50	6	
2JJRE 012 120 S04	1.2	1.2	12	50	4		2JJRE 030 160 S06	3	3	16	55	6	
2JJRE 012 160 S04	1.2	1.2	16	50	4		2JJRE 030 200 S06	3	3	20	60	6	
2JJRE 012 200 S04	1.2	1.2	20	50	4		2JJRE 030 250 S06	3	3	25	65	6	
2JJRE 012 250 S04	1.2	1.2	25	60	4		2JJRE 030 300 S06	3	3	30	70	6	
2JJRE 014 080 S04	1.4	1.4	8	45	4		2JJRE 030 350 S06	3	3	35	75	6	
2JJRE 014 100 S04	1.4	1.4	10	45	4		2JJRE 030 400 S06	3	3	40	80	6	
2JJRE 014 140 S04	1.4	1.4	14	50	4		2JJRE 030 450 S06	3	3	45	90	6	
2JJRE 014 160 S04	1.4	1.4	16	50	4		2JJRE 030 500 S06	3	3	50	100	6	
2JJRE 014 200 S04	1.4	1.4	20	50	4		2JJRE 030 600 S06	3	3	60	100	6	
2JJRE 014 220 S04	1.4	1.4	22	60	4		2JJRE 035 120 S06	3.5	3.5	12	50	6	
2JJRE 015 040 S04	1.5	1.5	4	45	4		2JJRE 035 160 S06	3.5	3.5	16	55	6	
2JJRE 015 060 S04	1.5	1.5	6	45	4		2JJRE 035 200 S06	3.5	3.5	20	60	6	
2JJRE 015 080 S04	1.5	1.5	8	45	4		2JJRE 035 250 S06	3.5	3.5	25	65	6	
2JJRE 015 100 S04	1.5	1.5	10	50	4		2JJRE 035 300 S06	3.5	3.5	30	70	6	
2JJRE 015 120 S04	1.5	1.5	12	50	4		2JJRE 035 350 S06	3.5	3.5	35	75	6	
2JJRE 015 140 S04	1.5	1.5	14	50	4		2JJRE 035 400 S06	3.5	3.5	40	80	6	
2JJRE 015 160 S04	1.5	1.5	16	50	4		2JJRE 040 080 S06	4	4	8	50	6	
2JJRE 015 180 S04	1.5	1.5	18	50	4		2JJRE 040 100 S06	4	4	10	50	6	
2JJRE 015 200 S04	1.5	1.5	20	50	4		2JJRE 040 120 S06	4	4	12	50	6	
2JJRE 015 220 S04	1.5	1.5	22	60	4		2JJRE 040 160 S06	4	4	16	55	6	
2JJRE 015 250 S04	1.5	1.5	25	60	4		2JJRE 040 200 S06	4	4	20	60	6	
2JJRE 015 350 S04	1.5	1.5	35	70	4		2JJRE 040 250 S06	4	4	25	65	6	
2JJRE 015 400 S04	1.5	1.5	40	80	4		2JJRE 040 300 S06	4	4	30	70	6	
2JJRE 016 060 S04	1.6	1.6	6	45	4		2JJRE 040 350 S06	4	4	35	75	6	
2JJRE 016 100 S04	1.6	1.6	10	50	4		2JJRE 040 400 S06	4	4	40	80	6	
2JJRE 016 140 S04	1.6	1.6	14	50	4		2JJRE 040 450 S06	4	4	45	90	6	
2JJRE 016 180 S04	1.6	1.6	18	50	4		2JJRE 040 500 S06	4	4	50	100	6	
2JJRE 016 200 S04	1.6	1.6	20	50	4		2JJRE 040 600 S06	4	4	60	100	6	
2JJRE 018 100 S04	1.8	1.8	10	50	4		2JJRE 045 120 S06	4.5	4.5	12	50	6	
2JJRE 018 120 S04	1.8	1.8	12	50	4		2JJRE 045 160 S06	4.5	4.5	16	55	6	
2JJRE 018 140 S04	1.8	1.8	14	50	4		2JJRE 045 200 S06	4.5	4.5	20	60	6	
2JJRE 018 160 S04	1.8	1.8	16	50	4		2JJRE 045 250 S06	4.5	4.5	25	65	6	
2JJRE 018 180 S04	1.8	1.8	18	50	4		2JJRE 045 300 S06	4.5	4.5	30	70	6	
2JJRE 018 200 S04	1.8	1.8	20	50	4		2JJRE 045 400 S06	4.5	4.5	40	80	6	
2JJRE 018 250 S04	1.8	1.8	25	60	4		2JJRE 050 160 S06	5	6	16	60	6	
2JJRE 020 060 S04	2	2	6	45	4		2JJRE 050 200 S06	5	6	20	60	6	
2JJRE 020 080 S04	2	2	8	45	4		2JJRE 050 250 S06	5	6	25	65	6	
2JJRE 020 100 S04	2	2	10	50	4		2JJRE 050 300 S06	5	6	30	70	6	
2JJRE 020 120 S04	2	2	12	50	4		2JJRE 050 350 S06	5	6	35	75	6	
2JJRE 020 140 S04	2	2	14	50	4		2JJRE 050 400 S06	5	6	40	80	6	
2JJRE 020 160 S04	2	2	16	50	4		2JJRE 050 500 S06	5	6	50	100	6	
2JJRE 020 180 S04	2	2	18	50	4		2JJRE 050 600 S06	5	6	60	100	6	
2JJRE 020 200 S04	2	2	20	50	4		2JJRE 060 200 S06	6	10	20	60	6	
2JJRE 020 220 S04	2	2	22	60	4		2JJRE 060 300 S06	6	10	30	75	6	
2JJRE 020 250 S04	2	2	25	60	4		2JJRE 060 400 S06	6	10	40	80	6	
2JJRE 020 300 S04	2	2	30	60	4		2JJRE 060 500 S06	6	10	50	90	6	
2JJRE 020 350 S04	2	2	35	70	4		2JJRE 060 600 S06	6	10	60	110	6	
2JJRE 020 400 S04	2	2	40	80	4		2JJRE 080 300 S08	8	12	30	80	8	
2JJRE 020 450 S04	2	2	45	90	4		2JJRE 080 500 S08	8	12	50	100	8	
2JJRE 020 500 S04	2	2	50	90	4		2JJRE 100 400 S10	10	15	40	90	10	
2JJRE 025 100 S04	2.5	2.5	10	50	4		2JJRE 100 600 S10	10	15	60	110	10	
2JJRE 025 120 S04	2.5	2.5	12	50	4		2JJRE 120 500 S12	12	18	50	100	12	
2JJRE 025 160 S04	2.5	2.5	16	50	4		2JJRE 120 700 S12	12	18	70	120	12	
2JJRE 025 200 S04	2.5	2.5	20	50	4								
2JJRE 025 250 S04	2.5	2.5	25	60	4								
2JJRE 025 300 S04	2.5	2.5	30	70	4								

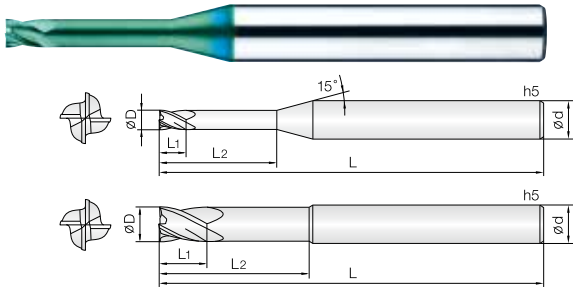

- 고정도강(HRc52~68), 프리하든강 계열의 고정밀 가공 엔드밀
- 고품량 실리콘계 코팅(Si) 처리하여 내마모성이 우수합니다.
- 고정밀 공차 적용으로 초정밀 가공에 적합합니다.
- 인선부 강성을 보강하여 날부치핑을 최소화 하였습니다.
- 초미립자 초경합금(0.2 $\mu$ m)을 채택, 고속절삭시 뛰어난 성능을 발휘합니다.

#### • Endmills for pre-hardened and hardened steels(HRc52~68)

- Good wear resistance by high quality Si-based PVD coating.
- High precise edge tolerance.
- Reinforced edge design for preventing edge chipping.
- Outstanding performance at high speed machining by ultra fine (0.2 $\mu$ m) WC grade.



Condition	D Size	D Tolerance	Condition	D Size	D Tolerance
$\varnothing D \neq \varnothing d$	$\varnothing 0.5 \sim 6$	+0 ~ -0.01mm	$\varnothing D = \varnothing d$	$\varnothing 6$	-0.005 ~ -0.015mm
	$\varnothing 8 \sim 12$	+0 ~ -0.015mm		$\varnothing 8 \sim 12$	-0.01 ~ -0.025mm

단위 : mm

Order Number	날경 Diameter D	날장 Length of cut L1	유효장 Effective Length L2	전장 Overall Length L	샙크 Shank Dia d	비고	Order Number	날경 Diameter D	날장 Length of cut L1	유효장 Effective Length L2	전장 Overall Length L	샙크 Shank Dia d	비고
4JJRE 005 010 S04	0.5	0.5	1	40	4		4JJRE 012 200 S04	1.2	1.2	20	60	4	
4JJRE 005 020 S04	0.5	0.5	2	40	4		4JJRE 014 060 S04	1.4	1.4	6	45	4	
4JJRE 005 030 S04	0.5	0.5	3	45	4		4JJRE 014 080 S04	1.4	1.4	8	45	4	
4JJRE 005 040 S04	0.5	0.5	4	45	4		4JJRE 014 100 S04	1.4	1.4	10	50	4	
4JJRE 005 050 S04	0.5	0.5	5	45	4		4JJRE 014 120 S04	1.4	1.4	12	50	4	
4JJRE 005 060 S04	0.5	0.5	6	45	4		4JJRE 014 140 S04	1.4	1.4	14	50	4	
4JJRE 005 080 S04	0.5	0.5	8	45	4		4JJRE 014 160 S04	1.4	1.4	16	50	4	
4JJRE 005 100 S04	0.5	0.5	10	50	4		4JJRE 015 040 S04	1.5	1.5	4	45	4	
4JJRE 006 010 S04	0.6	0.6	1	45	4		4JJRE 015 060 S04	1.5	1.5	6	45	4	
4JJRE 006 020 S04	0.6	0.6	2	45	4		4JJRE 015 080 S04	1.5	1.5	8	45	4	
4JJRE 006 030 S04	0.6	0.6	3	45	4		4JJRE 015 100 S04	1.5	1.5	10	50	4	
4JJRE 006 040 S04	0.6	0.6	4	45	4		4JJRE 015 120 S04	1.5	1.5	12	50	4	
4JJRE 006 050 S04	0.6	0.6	5	45	4		4JJRE 015 160 S04	1.5	1.5	16	50	4	
4JJRE 006 060 S04	0.6	0.6	6	45	4		4JJRE 015 180 S04	1.5	1.5	18	60	4	
4JJRE 006 080 S04	0.6	0.6	8	45	4		4JJRE 015 200 S04	1.5	1.5	20	60	4	
4JJRE 006 100 S04	0.6	0.6	10	50	4		4JJRE 015 250 S04	1.5	1.5	25	60	4	
4JJRE 006 120 S04	0.6	0.6	12	50	4		4JJRE 015 300 S04	1.5	1.5	30	70	4	
4JJRE 007 020 S04	0.7	0.7	2	45	4		4JJRE 016 060 S04	1.6	1.6	6	45	4	
4JJRE 007 040 S04	0.7	0.7	4	45	4		4JJRE 016 080 S04	1.6	1.6	8	45	4	
4JJRE 007 060 S04	0.7	0.7	6	45	4		4JJRE 016 100 S04	1.6	1.6	10	50	4	
4JJRE 007 080 S04	0.7	0.7	8	45	4		4JJRE 016 120 S04	1.6	1.6	12	50	4	
4JJRE 007 100 S04	0.7	0.7	10	50	4		4JJRE 016 140 S04	1.6	1.6	14	50	4	
4JJRE 008 010 S04	0.8	0.8	1	40	4		4JJRE 016 160 S04	1.6	1.6	16	50	4	
4JJRE 008 020 S04	0.8	0.8	2	40	4		4JJRE 016 180 S04	1.6	1.6	18	60	4	
4JJRE 008 030 S04	0.8	0.8	3	40	4		4JJRE 016 200 S04	1.6	1.6	20	60	4	
4JJRE 008 040 S04	0.8	0.8	4	40	4		4JJRE 016 250 S04	1.6	1.6	25	70	4	
4JJRE 008 050 S04	0.8	0.8	5	40	4		4JJRE 018 060 S04	1.8	1.8	6	45	4	
4JJRE 008 060 S04	0.8	0.8	6	40	4		4JJRE 018 080 S04	1.8	1.8	8	45	4	
4JJRE 008 080 S04	0.8	0.8	8	40	4		4JJRE 018 100 S04	1.8	1.8	10	50	4	
4JJRE 008 100 S04	0.8	0.8	10	50	4		4JJRE 018 120 S04	1.8	1.8	12	50	4	
4JJRE 008 120 S04	0.8	0.8	12	50	4		4JJRE 018 160 S04	1.8	1.8	16	50	4	
4JJRE 008 160 S04	0.8	0.8	16	50	4		4JJRE 018 200 S04	1.8	1.8	20	60	4	
4JJRE 010 020 S04	1	1	2	45	4		4JJRE 018 250 S04	1.8	1.8	25	70	4	
4JJRE 010 030 S04	1	1	3	45	4		4JJRE 020 040 S04	2	2	4	45	4	
4JJRE 010 040 S04	1	1	4	45	4		4JJRE 020 060 S04	2	2	6	45	4	
4JJRE 010 060 S04	1	1	6	45	4		4JJRE 020 080 S04	2	2	8	45	4	
4JJRE 010 080 S04	1	1	8	45	4		4JJRE 020 100 S04	2	2	10	50	4	
4JJRE 010 100 S04	1	1	10	50	4		4JJRE 020 120 S04	2	2	12	50	4	
4JJRE 010 120 S04	1	1	12	50	4		4JJRE 020 140 S04	2	2	14	50	4	
4JJRE 010 140 S04	1	1	14	50	4		4JJRE 020 160 S04	2	2	16	50	4	
4JJRE 010 160 S04	1	1	16	50	4		4JJRE 020 180 S04	2	2	18	50	4	
4JJRE 010 180 S04	1	1	18	60	4		4JJRE 020 200 S04	2	2	20	50	4	
4JJRE 010 200 S04	1	1	20	60	4		4JJRE 020 220 S04	2	2	22	60	4	
4JJRE 012 040 S04	1.2	1.2	4	45	4		4JJRE 020 250 S04	2	2	25	60	4	
4JJRE 012 060 S04	1.2	1.2	6	45	4		4JJRE 020 300 S04	2	2	30	70	4	
4JJRE 012 080 S04	1.2	1.2	8	45	4		4JJRE 025 100 S04	2.5	2.5	10	50	4	
4JJRE 012 100 S04	1.2	1.2	10	50	4		4JJRE 025 120 S04	2.5	2.5	12	50	4	
4JJRE 012 120 S04	1.2	1.2	12	50	4		4JJRE 025 160 S04	2.5	2.5	16	50	4	
4JJRE 012 160 S04	1.2	1.2	16	50	4		4JJRE 025 200 S04	2.5	2.5	20	50	4	
4JJRE 012 180 S04	1.2	1.2	18	60	4		4JJRE 025 250 S04	2.5	2.5	25	60	4	

단위 : mm

Order Number	날경 Diameter D	날장 Length of cut L1	유효장 Effective Length L2	전장 Overall Length L	샙크 Shank Dia d	비고	Order Number	날경 Diameter D	날장 Length of cut L1	유효장 Effective Length L2	전장 Overall Length L	샙크 Shank Dia d	비고
4JJRE 025 300 S04	2.5	2.5	30	70	4								
4JJRE 030 060 S06	3	3	6	45	6								
4JJRE 030 080 S06	3	3	8	45	6								
4JJRE 030 100 S06	3	3	10	50	6								
4JJRE 030 120 S06	3	3	12	50	6								
4JJRE 030160 S06	3	3	16	55	6								
4JJRE 030 200 S06	3	3	20	60	6								
4JJRE 030 250 S06	3	3	25	65	6								
4JJRE 030 300 S06	3	3	30	70	6								
4JJRE 030 350 S06	3	3	35	75	6								
4JJRE 030 400 S06	3	3	40	80	6								
4JJRE 030 450 S06	3	3	45	90	6								
4JJRE 030 500 S06	3	3	50	100	6								
4JJRE 030 600 S06	3	3	60	110	6								
4JJRE 035 120 S06	3.5	3.5	12	50	6								
4JJRE 035 160 S06	3.5	3.5	16	55	6								
4JJRE 035 200 S06	3.5	3.5	20	60	6								
4JJRE 035 250 S06	3.5	3.5	25	65	6								
4JJRE 035 300 S06	3.5	3.5	30	70	6								
4JJRE 035 350 S06	3.5	3.5	35	75	6								
4JJRE 035 400 S06	3.5	3.5	40	80	6								
4JJRE 040 060 S06	4	4	6	50	6								
4JJRE 040 080 S06	4	4	8	50	6								
4JJRE 040 100 S06	4	4	10	50	6								
4JJRE 040 120 S06	4	4	12	50	6								
4JJRE 040 160 S06	4	4	16	55	6								
4JJRE 040 200 S06	4	4	20	60	6								
4JJRE 040 250 S06	4	4	25	65	6								
4JJRE 040 300 S06	4	4	30	70	6								
4JJRE 040 400 S06	4	4	40	80	6								
4JJRE 040 450 S06	4	4	45	90	6								
4JJRE 040 500 S06	4	4	50	100	6								
4JJRE 040 600 S06	4	4	60	110	6								
4JJRE 045 120 S06	4.5	4.5	12	50	6								
4JJRE 045 160 S06	4.5	4.5	16	55	6								
4JJRE 045 200 S06	4.5	4.5	20	60	6								
4JJRE 045 250 S06	4.5	4.5	25	65	6								
4JJRE 045 300 S06	4.5	4.5	30	70	6								
4JJRE 045 400 S06	4.5	4.5	40	80	6								
4JJRE 050 160 S06	5	5	16	60	6								
4JJRE 050 200 S06	5	5	20	60	6								
4JJRE 050 250 S06	5	5	25	65	6								
4JJRE 050 300 S06	5	5	30	70	6								
4JJRE 050 400 S06	5	5	40	80	6								
4JJRE 050 500 S06	5	5	50	100	6								
4JJRE 050 600 S06	5	5	60	110	6								
4JJRE 060 200 S06	6	6	20	60	6								
4JJRE 060 300 S06	6	6	30	75	6								
4JJRE 060 400 S06	6	6	40	80	6								
4JJRE 060 500 S06	6	6	50	90	6								
4JJRE 060 600 S06	6	6	60	100	6								
4JJRE 080 250 S08	8	12	25	65	8								
4JJRE 080 400 S08	8	12	40	100	8								
4JJRE 080 500 S08	8	12	50	110	8								
4JJRE 100 300 S10	10	15	30	70	10								
4JJRE 100 500 S10	10	15	50	100	10								
4JJRE 100 600 S10	10	15	60	120	10								
4JJRE 120 400 S12	12	18	40	80	12								
4JJRE 120 600 S12	12	18	60	110	12								
4JJRE 120 700 S12	12	18	70	130	12								

# 2JJE 2 Flutes JJ End Mills for Hardened Steels

## 2날 고경도재 가공용 제이제이 엔드밀

JJ series

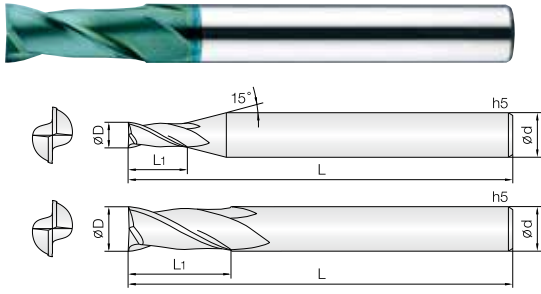

- 고경도강(HRc52~68), 프리하든강 계열의 고정밀 가공 엔드밀
- 고품량 실리콘계 코팅(Si) 처리하여 내마모성이 우수합니다.
- 고정밀 공차 적용으로 초정밀 가공에 적합합니다.
- 인선부 강성을 보강하여 날부치핑을 최소화 하였습니다.
- 국내최초 날경 0.03mm 제품부터 생산합니다.
- 초미립자 초경합금(0.2 $\mu$ m)을 채택, 고속절삭시 뛰어난 성능을 발휘합니다.

### • Endmills for pre-hardened and hardened steels(HRc52~68)

- Good wear resistance by high quality Si-based PVD coating.
- High precise edge tolerance.
- Reinforced edge design for preventing edge chipping.
- Produce down to 0.03mm in diameter endmills at the first time in Korea.
- Outstanding performance at high speed machining by ultra fine (0.2 $\mu$ m) WC grade.



Condition	D Size	D Tolerance	Condition	D Size	D Tolerance
øD ≠ ød	ø0.03 ~ 0.15	+0 ~ -0.005mm	øD = ød	ø3 ~ 6	-0.005 ~ -0.015mm
	ø0.2 ~ 6	+0 ~ -0.01mm		ø8 ~ 12	-0.01 ~ -0.025mm
	ø6.5 ~ 20	+0 ~ -0.015mm		ø14 ~ 20	-0.015 ~ -0.03mm

단위 : mm

Order Number	날경 Diameter D	날장 Length of cut L1	전장 Overall Length L	샙크 Shank Dia d	비고	Order Number	날경 Diameter D	날장 Length of cut L1	전장 Overall Length L	샙크 Shank Dia d	비고
2JJE 0003 00045 S04	0.03	0.045	40	4		2JJE 026 080 S04	2.6	8	45	4	
2JJE 0004 0006 S04	0.04	0.06	40	4		2JJE 027 080 S04	2.7	8	45	4	
2JJE 0005 0008 S04	0.05	0.08	40	4		2JJE 028 080 S04	2.8	8	45	4	
2JJE 0006 001 S04	0.06	0.1	40	4		2JJE 029 080 S04	2.9	8	45	4	
2JJE 0007 0012 S04	0.07	0.12	40	4		2JJE 030 080 S03	3	8	50	3	
2JJE 0008 0015 S04	0.08	0.15	40	4		2JJE 030 080 S04	3	8	45	4	
2JJE 0009 0017 S04	0.09	0.17	40	4		2JJE 030 080 S06	3	8	45	6	
2JJE 001 002 S04	0.1	0.2	40	4		2JJE 035 100 S06	3.5	10	45	6	
2JJE 0015 003 S04	0.15	0.3	40	4		2JJE 040 100 S04	4	10	45	4	
2JJE 002 004 S04	0.2	0.4	40	4		2JJE 040 110 S06	4	11	45	6	
2JJE 0025 005 S04	0.25	0.5	40	4		2JJE 045 110 S06	4.5	11	45	6	
2JJE 003 006 S04	0.3	0.6	40	4		2JJE 050 130 S06	5	13	50	6	
2JJE 0035 007 S04	0.35	0.7	40	4		2JJE 055 130 S06	5.5	13	50	6	
2JJE 004 008 S04	0.4	0.8	40	4		2JJE 060 130 S06	6	13	50	6	
2JJE 0045 009 S04	0.45	0.9	40	4		2JJE 065 160 S08	6.5	16	60	8	
2JJE 005 010 S04	0.5	1	40	4		2JJE 070 160 S08	7	16	60	8	
2JJE 0055 011 S04	0.55	1.1	40	4		2JJE 075 160 S08	7.5	16	60	8	
2JJE 006 012 S04	0.6	1.2	40	4		2JJE 080 190 S08	8	19	60	8	
2JJE 0065 013 S04	0.65	1.3	40	4		2JJE 085 190 S10	8.5	19	70	10	
2JJE 007 014 S04	0.7	1.4	40	4		2JJE 090 190 S10	9	19	70	10	
2JJE 0075 015 S04	0.75	1.5	40	4		2JJE 095 190 S10	9.5	19	70	10	
2JJE 008 016 S04	0.8	1.6	40	4		2JJE 100 220 S10	10	22	70	10	
2JJE 0085 017 S04	0.85	1.7	40	4		2JJE 105 220 S12	10.5	22	75	12	
2JJE 009 020 S04	0.9	2	40	4		2JJE 110 220 S12	11	22	75	12	
2JJE 0095 020 S04	0.95	2	40	4		2JJE 115 220 S12	11.5	22	75	12	
2JJE 010 025 S03	1	2.5	40	3		2JJE 120 260 S12	12	26	75	12	
2JJE 010 025 S04	1	2.5	40	4		2JJE 140 260 S14	14	26	80	14	
2JJE 010 025 S06	1	2.5	40	6		2JJE 140 260 S16	14	26	90	16	
2JJE 011 027 S04	1.1	2.7	40	4		2JJE 160 350 S16	16	35	100	16	
2JJE 012 030 S03	1.2	3	40	3		2JJE 180 350 S18	18	35	100	18	
2JJE 012 030 S04	1.2	3	40	4		2JJE 200 400 S20	20	40	100	20	
2JJE 013 032 S04	1.3	3.2	40	4							
2JJE 014 035 S04	1.4	3.5	40	4							
2JJE 015 040 S03	1.5	4	40	3							
2JJE 015 040 S04	1.5	4	40	4							
2JJE 015 040 S06	1.5	4	40	6							
2JJE 016 040 S04	1.6	4	40	4							
2JJE 017 042 S04	1.7	4.2	40	4							
2JJE 018 045 S04	1.8	4.5	40	4							
2JJE 019 050 S04	1.9	5	40	4							
2JJE 020 060 S03	2	6	40	3							
2JJE 020 060 S04	2	6	40	4							
2JJE 020 060 S06	2	6	40	6							
2JJE 021 060 S04	2.1	6	40	4							
2JJE 022 060 S04	2.2	6	40	4							
2JJE 023 060 S04	2.3	6	40	4							
2JJE 024 080 S04	2.4	8	45	4							
2JJE 025 080 S03	2.5	8	45	3							
2JJE 025 080 S04	2.5	8	45	4							
2JJE 025 080 S06	2.5	8	45	6							



# 4 Flutes JJ End Mills for Hardened Steels

## 4날 고정도재 가공용 제이제이 엔드밀

4J series

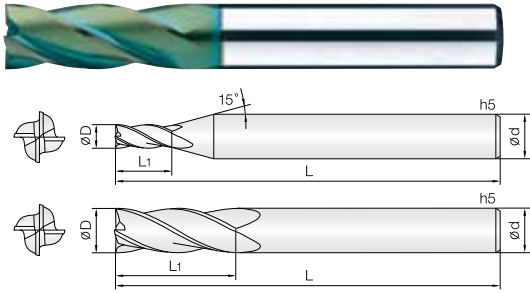

- 고경도강(HRc52~68), 프리하든강 계열의 고정밀 가공 엔드밀
- 고함량 실리콘계 코팅(Si) 처리하여 내마모성이 우수합니다.
- 고정밀 공차 적용으로 초정밀 가공에 적합합니다.
- 인선부 강성을 보강하여 날부치핑을 최소화 하였습니다.
- 초미립자 초경합금(0.2 $\mu$ m)을 채택, 고속절삭시 뛰어난 성능을 발휘합니다.

### Endmills for pre-hardened and hardened steels(HRc52~68)

- Good wear resistance by high quality Si-based PVD coating.
- High precise edge tolerance.
- Reinforced edge design for preventing edge chipping.
- Outstanding performance at high speed machining by ultra fine (0.2 $\mu$ m) WC grade.



Shield Edge 413P

Condition	D Size	D Tolerance	Condition	D Size	D Tolerance
$\emptyset D \neq \emptyset d$	$\emptyset 0.3 \sim 6$	+0 ~ -0.01mm	$\emptyset D = \emptyset d$	$\emptyset 3 \sim 6$	-0.005 ~ -0.015mm
	$\emptyset 8 \sim 20$	+0 ~ -0.015mm		$\emptyset 8 \sim 12$	-0.01 ~ -0.025mm
		$\emptyset 14 \sim 20$		-0.015 ~ -0.03mm	

단위 : mm

Order Number	날경 Diameter D	날장 Length of cut L1	전장 Overall Length L	샙크 Shank Dia d	비고
4JJE 003 006 S04	0.3	0.6	40	4	
4JJE 004 008 S04	0.4	0.8	40	4	
4JJE 005 010 S04	0.5	1	40	4	
4JJE 006 012 S04	0.6	1.2	40	4	
4JJE 007 014 S04	0.7	1.4	40	4	
4JJE 008 016 S04	0.8	1.6	40	4	
4JJE 009 018 S04	0.9	1.8	40	4	
4JJE 010 025 S03	1	2.5	40	3	
4JJE 010 025 S04	1	2.5	40	4	
4JJE 010 025 S06	1	2.5	40	6	
4JJE 012 030 S03	1.2	3	40	3	
4JJE 012 030 S04	1.2	3	40	4	
4JJE 015 040 S03	1.5	4	40	3	
4JJE 015 040 S04	1.5	4	40	4	
4JJE 015 040 S06	1.5	4	40	6	
4JJE 020 060 S03	2	6	40	3	
4JJE 020 060 S04	2	6	40	4	
4JJE 020 060 S06	2	6	40	6	
4JJE 025 080 S03	2.5	8	45	3	
4JJE 025 080 S04	2.5	8	45	4	
4JJE 025 080 S06	2.5	8	45	6	
4JJE 030 080 S03	3	8	50	3	
4JJE 030 080 S04	3	8	45	4	
4JJE 030 080 S06	3	8	45	6	
4JJE 035 100 S06	3.5	10	45	6	
4JJE 040 110 S04	4	11	45	4	
4JJE 040 110 S06	4	11	45	6	
4JJE 045 110 S06	4.5	11	45	6	
4JJE 050 130 S06	5	13	50	6	
4JJE 055 130 S06	5.5	13	50	6	
4JJE 060 130 S06	6	13	50	6	
4JJE 080 190 S08	8	19	60	8	
4JJE 100 220 S10	10	22	70	10	
4JJE 120 260 S12	12	26	75	12	
4JJE 140 300 S14	14	30	90	14	
4JJE 160 350 S16	16	35	100	16	
4JJE 200 400 S20	20	40	100	20	

Order Number	날경 Diameter D	날장 Length of cut L1	전장 Overall Length L	샙크 Shank Dia d	비고

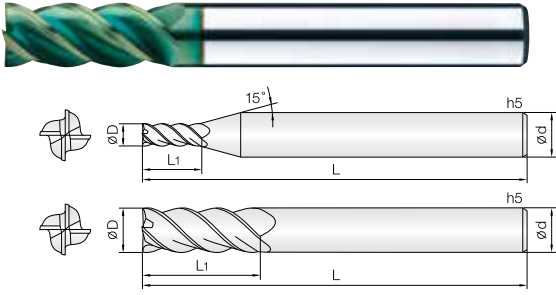

- 고경도강(HRc52~68), 프리하든강 계열의 고정밀 가공 엔드밀
- 고품량 실리콘계 코팅(Si) 처리하여 내마모성이 우수합니다.
- 고정밀 공차 적용으로 초정밀 가공에 적합합니다.
- 인선부 강성을 보강하여 날부치핑을 최소화 하였습니다.
- 국내최초 날경 0.03mm 제품부터 생산합니다.
- 초미립자 초경합금(0.2 $\mu$ m)을 채택, 고속절삭시 뛰어난 성능을 발휘합니다.

#### • Endmills for pre-hardened and hardened steels(HRc52~68)

- Good wear resistance by high quality Si-based PVD coating.
- High precise edge tolerance.
- Reinforced edge design for preventing edge chipping.
- Produce down to 0.03mm in diameter endmills at the first time in Korea.
- Outstanding performance at high speed machining by ultra fine (0.2 $\mu$ m) WC grade.

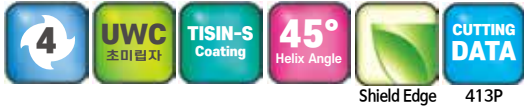

Condition	D Size	D Tolerance	Condition	D Size	D Tolerance
$\varnothing D \neq \varnothing d$	$\varnothing 0.3 \sim 6$	+0 ~ -0.01mm	$\varnothing D = \varnothing d$	$\varnothing 6$	-0.005 ~ -0.015mm
	$\varnothing 7 \sim 20$	+0 ~ -0.015mm		$\varnothing 8 \sim 12$	-0.01 ~ -0.025mm
		$\varnothing 14 \sim 20$		-0.015 ~ -0.03mm	

단위 : mm

Order Number	날경 Diameter D	날장 Length of cut L1	전장 Overall Length L	샙크 Shank Dia d	비고	Order Number	날경 Diameter D	날장 Length of cut L1	전장 Overall Length L	샙크 Shank Dia d	비고
New 4JJHE 003 006 S04	0.3	0.6	40	4		4JJHE 060 200 S06	6	20	60	6	
New 4JJHE 004 008 S04	0.4	0.8	40	4		4JJHE 060 250 S06	6	25	70	6	
New 4JJHE 005 008 S04	0.5	0.8	40	4		4JJHE 060 300 S06	6	30	75	6	
New 4JJHE 005 010 S04	0.5	1	40	4		4JJHE 070 160 S08	7	16	60	8	
New 4JJHE 006 009 S04	0.6	0.9	40	4		4JJHE 080 200 S08	8	20	60	8	
New 4JJHE 006 012 S04	0.6	1.2	40	4		4JJHE 080 250 S08	8	25	70	8	
New 4JJHE 008 012 S04	0.8	1.2	40	4		4JJHE 080 300 S08	8	30	80	8	
New 4JJHE 008 020 S04	0.8	2	40	4		4JJHE 080 400 S08	8	40	90	8	
New 4JJHE 010 015 S04	1	1.5	40	4		4JJHE 090 220 S10	9	22	70	10	
4JJHE 010 015 S06	1	1.5	40	6		4JJHE 100 220 S10	10	22	70	10	
New 4JJHE 010 025 S04	1	2.5	40	4		4JJHE 100 300 S10	10	30	80	10	
4JJHE 010 025 S06	1	2.5	40	6		4JJHE 100 400 S10	10	40	90	10	
New 4JJHE 010 035 S04	1	3.5	40	4		4JJHE 100 500 S10	10	50	100	10	
4JJHE 010 035 S06	1	3.5	40	6		4JJHE 120 260 S12	12	26	75	12	
4JJHE 010 050 S06	1	5	45	6		4JJHE 120 350 S12	12	35	90	12	
New 4JJHE 015 040 S04	1.5	4	40	4		4JJHE 120 500 S12	12	50	100	12	
4JJHE 015 040 S06	1.5	4	40	6		4JJHE 120 600 S12	12	60	110	12	
New 4JJHE 015 060 S04	1.5	6	40	4		4JJHE 140 350 S14	14	35	90	14	
4JJHE 015 060 S06	1.5	6	40	6		4JJHE 140 550 S14	14	55	110	14	
4JJHE 015 080 S06	1.5	8	40	6		4JJHE 160 350 S16	16	35	90	16	
New 4JJHE 020 030 S04	2	3	40	4		4JJHE 160 500 S16	16	50	110	16	
4JJHE 020 030 S06	2	3	40	6		4JJHE 160 700 S16	16	70	130	16	
New 4JJHE 020 050 S04	2	5	40	4		4JJHE 180 380 S18	18	38	100	18	
4JJHE 020 050 S06	2	5	40	6		4JJHE 200 400 S20	20	40	100	20	
4JJHE 020 080 S06	2	8	40	6		4JJHE 200 550 S20	20	55	120	20	
4JJHE 020 100 S06	2	10	45	6		4JJHE 200 750 S20	20	75	150	20	
New 4JJHE 025 060 S04	2.5	6	45	4							
4JJHE 025 060 S06	2.5	6	45	6							
New 4JJHE 025 080 S04	2.5	8	45	4							
4JJHE 025 080 S06	2.5	8	45	6							
4JJHE 025 100 S06	2.5	10	50	6							
New 4JJHE 030 060 S04	3	6	45	4							
4JJHE 030 060 S06	3	6	45	6							
New 4JJHE 030 080 S04	3	8	45	4							
4JJHE 030 080 S06	3	8	45	6							
4JJHE 030 120 S06	3	12	50	6							
4JJHE 030 150 S06	3	15	50	6							
4JJHE 035 080 S06	3.5	8	45	6							
4JJHE 040 080 S06	4	8	45	6							
4JJHE 040 110 S06	4	11	45	6							
4JJHE 040 150 S06	4	15	55	6							
4JJHE 040 200 S06	4	20	60	6							
4JJHE 045 110 S06	4.5	11	50	6							
4JJHE 050 100 S06	5	10	50	6							
4JJHE 050 130 S06	5	13	50	6							
4JJHE 050 200 S06	5	20	60	6							
4JJHE 050 250 S06	5	25	70	6							
4JJHE 050 300 S06	5	30	75	6							
4JJHE 060 130 S06	6	13	50	6							
4JJHE 060 150 S06	6	15	55	6							



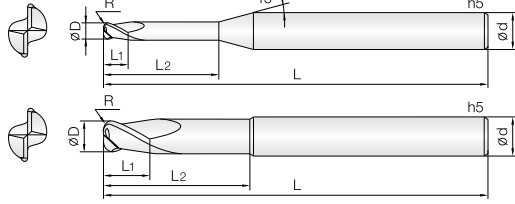

- 고정도강(HRc52~68), 프리하든강 계열의 고정밀 가공 엔드밀
- 고품량 실리콘계 코팅(Si) 처리하여 내마모성이 우수합니다.
- 고정밀 공차 적용으로 초정밀 가공에 적합합니다.
- 코너R 형상을 날부치핑이 적도록 설계하였습니다.
- 다양한 코너R과 유효장으로 맞춤 가공이 가능합니다.
- 초미립자 초경합금(0.2µm)을 채택, 고속절삭시 뛰어난 성능을 발휘합니다.

#### • Endmills for pre-hardened and hardened steels(HRc52~68)

- Good wear resistance by high quality Si-based PVD coating.
- High precise edge tolerance.
- Designed for minimizing edge chipping by corner R shape.
- Various corner R and flute length for wide range application.
- Outstanding performance at high speed machining by ultra fine (0.2µm) WC grade.

2

UWC  
초미립자

TISIN-S  
Coating

R

R

R

30°  
Helix Angle

CUTTING  
DATA

R0.2 ~ 0.5   R1 ~ 1.5   R2 ~ 3   415P

Condition	D Size	D Tolerance
ØD ≠ Ød	Ø0.2 ~ 16	+0 ~ -0.01mm

Condition	D Size	D Tolerance
ØD = Ød	Ø6 ~ 12	-0.005 ~ -0.015mm
	Ø16	-0.01 ~ -0.02mm

단위 : mm

Order Number	날경 D × R	날장 Length of cut L1	유효장 Effective Length L2	전장 Overall Length L	생크 Shank Dia d	비고	Order Number	날경 D × R	날장 Length of cut L1	유효장 Effective Length L2	전장 Overall Length L	생크 Shank Dia d	비고
2JJCR 002 0002 005	0.2 X R0.02	0.2	0.5	40	4		2JJCR 005 001 040	0.5 X R0.1	0.5	4	45	4	
2JJCR 002 0002 010	0.2 X R0.02	0.2	1	40	4		2JJCR 005 001 050	0.5 X R0.1	0.5	5	45	4	
2JJCR 002 0002 015	0.2 X R0.02	0.2	1.5	40	4		2JJCR 005 001 060	0.5 X R0.1	0.5	6	45	4	
2JJCR 002 0005 005	0.2 X R0.05	0.2	0.5	40	4		2JJCR 005 001 080	0.5 X R0.1	0.5	8	45	4	
2JJCR 002 0005 010	0.2 X R0.05	0.2	1	40	4		2JJCR 005 001 100	0.5 X R0.1	0.5	10	45	4	
2JJCR 002 0005 015	0.2 X R0.05	0.2	1.5	40	4		2JJCR 006 0002 020	0.6 X R0.02	0.6	2	45	4	
2JJCR 003 0002 010	0.3 X R0.02	0.3	1	40	4		2JJCR 006 0002 030	0.6 X R0.02	0.6	3	45	4	
2JJCR 003 0002 020	0.3 X R0.02	0.3	2	40	4		2JJCR 006 0002 040	0.6 X R0.02	0.6	4	45	4	
2JJCR 003 0002 030	0.3 X R0.02	0.3	3	40	4		2JJCR 006 0002 060	0.6 X R0.02	0.6	6	45	4	
2JJCR 003 0005 010	0.3 X R0.05	0.3	1	40	4		2JJCR 006 0002 080	0.6 X R0.02	0.6	8	45	4	
2JJCR 003 0005 020	0.3 X R0.05	0.3	2	40	4		2JJCR 0060002 100	0.6 X R0.02	0.6	10	45	4	
2JJCR 003 0005 030	0.3 X R0.05	0.3	3	40	4		2JJCR 0060002 120	0.6 X R0.02	0.6	12	50	4	
2JJCR 004 0002 010	0.4 X R0.02	0.4	1	40	4		2JJCR 006 0005 020	0.6 X R0.05	0.6	2	45	4	
2JJCR 004 0002 020	0.4 X R0.02	0.4	2	40	4		2JJCR 006 0005 030	0.6 X R0.05	0.6	3	45	4	
2JJCR 004 0002 030	0.4 X R0.02	0.4	3	40	4		2JJCR 006 0005 040	0.6 X R0.05	0.6	4	45	4	
2JJCR 004 0002 040	0.4 X R0.02	0.4	4	40	4		2JJCR 006 0005 060	0.6 X R0.05	0.6	6	45	4	
2JJCR 004 0005 010	0.4 X R0.05	0.4	1	40	4		2JJCR 006 0005 080	0.6 X R0.05	0.6	8	45	4	
2JJCR 004 0005 020	0.4 X R0.05	0.4	2	40	4		2JJCR 0060005 100	0.6 X R0.05	0.6	10	45	4	
2JJCR 004 0005 030	0.4 X R0.05	0.4	3	40	4		2JJCR 0060005 120	0.6 X R0.05	0.6	12	50	4	
2JJCR 004 0005 040	0.4 X R0.05	0.4	4	40	4		2JJCR 006 001 020	0.6 X R0.1	0.6	2	45	4	
2JJCR 004 001 010	0.4 X R0.1	0.4	1	40	4		2JJCR 006 001 030	0.6 X R0.1	0.6	3	45	4	
2JJCR 004 001 015	0.4 X R0.1	0.4	1.5	40	4		2JJCR 006 001 040	0.6 X R0.1	0.6	4	45	4	
2JJCR 004 001 020	0.4 X R0.1	0.4	2	40	4		2JJCR 006 001 060	0.6 X R0.1	0.6	6	45	4	
2JJCR 004 001 030	0.4 X R0.1	0.4	3	40	4		2JJCR 006 001 080	0.6 X R0.1	0.6	8	45	4	
2JJCR 004 001 040	0.4 X R0.1	0.4	4	40	4		2JJCR 006001 100	0.6 X R0.1	0.6	10	45	4	
2JJCR 005 0002 010	0.5 X R0.02	0.5	1	45	4		2JJCR 006001 120	0.6 X R0.1	0.6	12	50	4	
2JJCR 005 0002 015	0.5 X R0.02	0.5	1.5	45	4		2JJCR 007 001 020	0.7 X R0.1	0.7	2	45	4	
2JJCR 005 0002 020	0.5 X R0.02	0.5	2	45	4		2JJCR 007 001 040	0.7 X R0.1	0.7	4	45	4	
2JJCR 005 0002 025	0.5 X R0.02	0.5	2.5	45	4		2JJCR 007 001 060	0.7 X R0.1	0.7	6	45	4	
2JJCR 005 0002 030	0.5 X R0.02	0.5	3	45	4		2JJCR 007 001 080	0.7 X R0.1	0.7	8	45	4	
2JJCR 005 0002 040	0.5 X R0.02	0.5	4	45	4		2JJCR 007 001 100	0.7 X R0.1	0.7	10	45	4	
2JJCR 005 0002 050	0.5 X R0.02	0.5	5	45	4		2JJCR 008 0002 020	0.8 X R0.02	0.8	2	45	4	
2JJCR 005 0002 060	0.5 X R0.02	0.5	6	45	4		2JJCR 008 0002 040	0.8 X R0.02	0.8	4	45	4	
2JJCR 005 0002 080	0.5 X R0.02	0.5	8	45	4		2JJCR 008 0002 060	0.8 X R0.02	0.8	6	45	4	
2JJCR 005 0002 100	0.5 X R0.02	0.5	10	45	4		2JJCR 008 0002 080	0.8 X R0.02	0.8	8	45	4	
2JJCR 005 0005 010	0.5 X R0.05	0.5	1	45	4		2JJCR 008 0002 100	0.8 X R0.02	0.8	10	45	4	
2JJCR 005 0005 015	0.5 X R0.05	0.5	1.5	45	4		2JJCR 008 0002 120	0.8 X R0.02	0.8	12	50	4	
2JJCR 005 0005 020	0.5 X R0.05	0.5	2	45	4		2JJCR 008 0005 020	0.8 X R0.05	0.8	2	45	4	
2JJCR 005 0005 025	0.5 X R0.05	0.5	2.5	45	4		2JJCR 008 0005 040	0.8 X R0.05	0.8	4	45	4	
2JJCR 005 0005 030	0.5 X R0.05	0.5	3	45	4		2JJCR 008 0005 060	0.8 X R0.05	0.8	6	45	4	
2JJCR 005 0005 040	0.5 X R0.05	0.5	4	45	4		2JJCR 008 0005 080	0.8 X R0.05	0.8	8	45	4	
2JJCR 005 0005 050	0.5 X R0.05	0.5	5	45	4		2JJCR 008 0005 100	0.8 X R0.05	0.8	10	45	4	
2JJCR 005 0005 060	0.5 X R0.05	0.5	6	45	4		2JJCR 008 0005 120	0.8 X R0.05	0.8	12	50	4	
2JJCR 005 0005 080	0.5 X R0.05	0.5	8	45	4		2JJCR 008 001 020	0.8 X R0.1	0.8	2	45	4	
2JJCR 005 0005 100	0.5 X R0.05	0.5	10	45	4		2JJCR 008 001 040	0.8 X R0.1	0.8	4	45	4	
2JJCR 005 001 010	0.5 X R0.1	0.5	1	45	4		2JJCR 008 001 060	0.8 X R0.1	0.8	6	45	4	
2JJCR 005 001 015	0.5 X R0.1	0.5	1.5	45	4		2JJCR 008 001 080	0.8 X R0.1	0.8	8	45	4	
2JJCR 005 001 020	0.5 X R0.1	0.5	2	45	4		2JJCR 008 001 100	0.8 X R0.1	0.8	10	45	4	
2JJCR 005 001 025	0.5 X R0.1	0.5	2.5	45	4		2JJCR 008 001 120	0.8 X R0.1	0.8	12	50	4	
2JJCR 005 001 030	0.5 X R0.1	0.5	3	45	4		2JJCR 008 002 020	0.8 X R0.2	0.8	2	45	4	



단위 : mm

Order Number	날경 D×R	날장 Length of cut L1	유효장 Effective Length L2	전장 Overall Length L	샙크 Dia d	비고	Order Number	날경 D×R	날장 Length of cut L1	유효장 Effective Length L2	전장 Overall Length L	샙크 Dia d	비고
2JJCR 008 002 040	0.8 X R0.2	0.8	4	45	4		2JJCR 012 001 100	1.2 X R0.1	1.2	10	50	4	
2JJCR 008 002 060	0.8 X R0.2	0.8	6	45	4		2JJCR 012 001 120	1.2 X R0.1	1.2	12	50	4	
2JJCR 008 002 080	0.8 X R0.2	0.8	8	45	4		2JJCR 012 001 140	1.2 X R0.1	1.2	14	50	4	
2JJCR 008 002 100	0.8 X R0.2	0.8	10	45	4		2JJCR 012 001 160	1.2 X R0.1	1.2	16	50	4	
2JJCR 008 002 120	0.8 X R0.2	0.8	12	50	4		2JJCR 012 001 200	1.2 X R0.1	1.2	20	50	4	
2JJCR 010 0002 040	1 X R0.02	1	4	45	4		2JJCR 012 002 040	1.2 X R0.2	1.2	4	45	4	
2JJCR 010 0002 060	1 X R0.02	1	6	45	4		2JJCR 012 002 060	1.2 X R0.2	1.2	6	45	4	
2JJCR 010 0002 080	1 X R0.02	1	8	45	4		2JJCR 012 002 080	1.2 X R0.2	1.2	8	45	4	
2JJCR 010 0002 100	1 X R0.02	1	10	50	4		2JJCR 012 002 100	1.2 X R0.2	1.2	10	50	4	
2JJCR 010 0002 120	1 X R0.02	1	12	50	4		2JJCR 012 002 120	1.2 X R0.2	1.2	12	50	4	
2JJCR 010 0002 140	1 X R0.02	1	14	50	4		2JJCR 012 002 140	1.2 X R0.2	1.2	14	50	4	
2JJCR 010 0002 160	1 X R0.02	1	16	50	4		2JJCR 012 002 160	1.2 X R0.2	1.2	16	50	4	
2JJCR 010 0002 200	1 X R0.02	1	20	50	4		2JJCR 012 002 200	1.2 X R0.2	1.2	20	50	4	
2JJCR 010 0005 040	1 X R0.05	1	4	45	4		2JJCR 012 003 040	1.2 X R0.3	1.2	4	45	4	
2JJCR 010 0005 060	1 X R0.05	1	6	45	4		2JJCR 012 003 060	1.2 X R0.3	1.2	6	45	4	
2JJCR 010 0005 080	1 X R0.05	1	8	45	4		2JJCR 012 003 080	1.2 X R0.3	1.2	8	45	4	
2JJCR 010 0005 100	1 X R0.05	1	10	50	4		2JJCR 012 003 100	1.2 X R0.3	1.2	10	50	4	
2JJCR 010 0005 120	1 X R0.05	1	12	50	4		2JJCR 012 003 120	1.2 X R0.3	1.2	12	50	4	
2JJCR 010 0005 140	1 X R0.05	1	14	50	4		2JJCR 012 003 140	1.2 X R0.3	1.2	14	50	4	
2JJCR 010 0005 160	1 X R0.05	1	16	50	4		2JJCR 012 003 160	1.2 X R0.3	1.2	16	50	4	
2JJCR 010 0005 200	1 X R0.05	1	20	50	4		2JJCR 012 003 200	1.2 X R0.3	1.2	20	50	4	
2JJCR 010 001 040	1 X R0.1	1	4	45	4		2JJCR 015 0002 040	1.5 X R0.02	1.5	4	45	4	
2JJCR 010 001 060	1 X R0.1	1	6	45	4		2JJCR 015 0002 060	1.5 X R0.02	1.5	6	45	4	
2JJCR 010 001 080	1 X R0.1	1	8	45	4		2JJCR 015 0002 080	1.5 X R0.02	1.5	8	45	4	
2JJCR 010 001 100	1 X R0.1	1	10	50	4		2JJCR 015 0002 100	1.5 X R0.02	1.5	10	50	4	
2JJCR 010 001 120	1 X R0.1	1	12	50	4		2JJCR 015 0002 120	1.5 X R0.02	1.5	12	50	4	
2JJCR 010 001 140	1 X R0.1	1	14	50	4		2JJCR 015 0002 140	1.5 X R0.02	1.5	14	50	4	
2JJCR 010 001 160	1 X R0.1	1	16	50	4		2JJCR 015 0002 160	1.5 X R0.02	1.5	16	50	4	
2JJCR 010 001 200	1 X R0.1	1	20	50	4		2JJCR 015 0002 200	1.5 X R0.02	1.5	20	50	4	
2JJCR 010 002 040	1 X R0.2	1	4	45	4		2JJCR 015 0005 040	1.5 X R0.05	1.5	4	45	4	
2JJCR 010 002 060	1 X R0.2	1	6	45	4		2JJCR 015 0005 060	1.5 X R0.05	1.5	6	45	4	
2JJCR 010 002 080	1 X R0.2	1	8	45	4		2JJCR 015 0005 080	1.5 X R0.05	1.5	8	45	4	
2JJCR 010 002 100	1 X R0.2	1	10	50	4		2JJCR 015 0005 100	1.5 X R0.05	1.5	10	50	4	
2JJCR 010 002 120	1 X R0.2	1	12	50	4		2JJCR 015 0005 120	1.5 X R0.05	1.5	12	50	4	
2JJCR 010 002 140	1 X R0.2	1	14	50	4		2JJCR 015 0005 140	1.5 X R0.05	1.5	14	50	4	
2JJCR 010 002 160	1 X R0.2	1	16	50	4		2JJCR 015 0005 160	1.5 X R0.05	1.5	16	50	4	
2JJCR 010 002 200	1 X R0.2	1	20	50	4		2JJCR 015 0005 200	1.5 X R0.05	1.5	20	50	4	
2JJCR 010 003 040	1 X R0.3	1	4	45	4		2JJCR 015 001 040	1.5 X R0.1	1.5	4	45	4	
2JJCR 010 003 060	1 X R0.3	1	6	45	4		2JJCR 015 001 060	1.5 X R0.1	1.5	6	45	4	
2JJCR 010 003 080	1 X R0.3	1	8	45	4		2JJCR 015 001 080	1.5 X R0.1	1.5	8	45	4	
2JJCR 010 003 100	1 X R0.3	1	10	50	4		2JJCR 015 001 100	1.5 X R0.1	1.5	10	50	4	
2JJCR 010 003 120	1 X R0.3	1	12	50	4		2JJCR 015 001 120	1.5 X R0.1	1.5	12	50	4	
2JJCR 010 003 140	1 X R0.3	1	14	50	4		2JJCR 015 001 140	1.5 X R0.1	1.5	14	50	4	
2JJCR 010 003 160	1 X R0.3	1	16	50	4		2JJCR 015 001 160	1.5 X R0.1	1.5	16	50	4	
2JJCR 010 003 200	1 X R0.3	1	20	50	4		2JJCR 015 001 200	1.5 X R0.1	1.5	20	50	4	
2JJCR 012 0002 040	1.2 X R0.02	1.2	4	45	4		2JJCR 015 002 040	1.5 X R0.2	1.5	4	45	4	
2JJCR 012 0002 060	1.2 X R0.02	1.2	6	45	4		2JJCR 015 002 060	1.5 X R0.2	1.5	6	45	4	
2JJCR 012 0002 080	1.2 X R0.02	1.2	8	45	4		2JJCR 015 002 080	1.5 X R0.2	1.5	8	45	4	
2JJCR 012 0002 100	1.2 X R0.02	1.2	10	50	4		2JJCR 015 002 100	1.5 X R0.2	1.5	10	50	4	
2JJCR 012 0002 120	1.2 X R0.02	1.2	12	50	4		2JJCR 015 002 120	1.5 X R0.2	1.5	12	50	4	
2JJCR 012 0002 140	1.2 X R0.02	1.2	14	50	4		2JJCR 015 002 140	1.5 X R0.2	1.5	14	50	4	
2JJCR 012 0002 160	1.2 X R0.02	1.2	16	50	4		2JJCR 015 002 160	1.5 X R0.2	1.5	16	50	4	
2JJCR 012 0002 200	1.2 X R0.02	1.2	20	50	4		2JJCR 015 002 200	1.5 X R0.2	1.5	20	50	4	
2JJCR 012 0005 040	1.2 X R0.05	1.2	4	45	4		2JJCR 015 003 040	1.5 X R0.3	1.5	4	45	4	
2JJCR 012 0005 060	1.2 X R0.05	1.2	6	45	4		2JJCR 015 003 060	1.5 X R0.3	1.5	6	45	4	
2JJCR 012 0005 080	1.2 X R0.05	1.2	8	45	4		2JJCR 015 003 080	1.5 X R0.3	1.5	8	45	4	
2JJCR 012 0005 100	1.2 X R0.05	1.2	10	50	4		2JJCR 015 003 100	1.5 X R0.3	1.5	10	50	4	
2JJCR 012 0005 120	1.2 X R0.05	1.2	12	50	4		2JJCR 015 003 120	1.5 X R0.3	1.5	12	50	4	
2JJCR 012 0005 140	1.2 X R0.05	1.2	14	50	4		2JJCR 015 003 140	1.5 X R0.3	1.5	14	50	4	
2JJCR 012 0005 160	1.2 X R0.05	1.2	16	50	4		2JJCR 015 003 160	1.5 X R0.3	1.5	16	50	4	
2JJCR 012 0005 200	1.2 X R0.05	1.2	20	50	4		2JJCR 015 003 200	1.5 X R0.3	1.5	20	50	4	
2JJCR 012 001 040	1.2 X R0.1	1.2	4	45	4		2JJCR 015 005 040	1.5 X R0.5	1.5	4	45	4	
2JJCR 012 001 060	1.2 X R0.1	1.2	6	45	4		2JJCR 015 005 060	1.5 X R0.5	1.5	6	45	4	
2JJCR 012 001 080	1.2 X R0.1	1.2	8	45	4		2JJCR 015 005 080	1.5 X R0.5	1.5	8	45	4	

단위 : mm

Order Number	날경 D × R	날장 Length of cut L1	유효장 Effective Length L2	전장 Overall Length L	생크 Shank Dia d	비고	Order Number	날경 D × R	날장 Length of cut L1	유효장 Effective Length L2	전장 Overall Length L	생크 Shank Dia d	비고
2JJCR 015 005 100	1.5 X R0.5	1.5	10	50	4		2JJCR 025 002 200	2.5 X R0.2	2.5	20	50	4	
2JJCR 015 005 120	1.5 X R0.5	1.5	12	50	4		2JJCR 025 003 100	2.5 X R0.3	2.5	10	50	4	
2JJCR 015 005 140	1.5 X R0.5	1.5	14	50	4		2JJCR 025 003 160	2.5 X R0.3	2.5	16	50	4	
2JJCR 015 005 160	1.5 X R0.5	1.5	16	50	4		2JJCR 025 003 200	2.5 X R0.3	2.5	20	50	4	
2JJCR 015 005 200	1.5 X R0.5	1.5	20	50	4		2JJCR 025 005 100	2.5 X R0.5	2.5	10	50	4	
2JJCR 020 0002 060	2 X R0.02	2	6	45	4		2JJCR 025 005 160	2.5 X R0.5	2.5	16	50	4	
2JJCR 020 0002 080	2 X R0.02	2	8	45	4		2JJCR 025 005 200	2.5 X R0.5	2.5	20	50	4	
2JJCR 020 0002 100	2 X R0.02	2	10	50	4		2JJCR 030 001 100	3 X R0.1	3	10	50	6	
2JJCR 020 0002 120	2 X R0.02	2	12	50	4		2JJCR 030 001 120	3 X R0.1	3	12	50	6	
2JJCR 020 0002 140	2 X R0.02	2	14	50	4		2JJCR 030 001 160	3 X R0.1	3	16	55	6	
2JJCR 020 0002 160	2 X R0.02	2	16	50	4		2JJCR 030 001 200	3 X R0.1	3	20	60	6	
2JJCR 020 0002 200	2 X R0.02	2	20	50	4		2JJCR 030 001 250	3 X R0.1	3	25	65	6	
2JJCR 020 0002 250	2 X R0.02	2	25	60	4		2JJCR 030 001 300	3 X R0.1	3	30	70	6	
2JJCR 020 0005 060	2 X R0.05	2	6	45	4		2JJCR 030 001 350	3 X R0.1	3	35	75	6	
2JJCR 020 0005 080	2 X R0.05	2	8	45	4		2JJCR 030 001 400	3 X R0.1	3	40	80	6	
2JJCR 020 0005 100	2 X R0.05	2	10	50	4		2JJCR 030 002 100	3 X R0.2	3	10	50	6	
2JJCR 020 0005 120	2 X R0.05	2	12	50	4		2JJCR 030 002 120	3 X R0.2	3	12	50	6	
2JJCR 020 0005 140	2 X R0.05	2	14	50	4		2JJCR 030 002 160	3 X R0.2	3	16	55	6	
2JJCR 020 0005 160	2 X R0.05	2	16	50	4		2JJCR 030 002 200	3 X R0.2	3	20	60	6	
2JJCR 020 0005 200	2 X R0.05	2	20	50	4		2JJCR 030 002 250	3 X R0.2	3	25	65	6	
2JJCR 020 0005 250	2 X R0.05	2	25	60	4		2JJCR 030 002 300	3 X R0.2	3	30	70	6	
2JJCR 020 001 060	2 X R0.1	2	6	45	4		2JJCR 030 002 350	3 X R0.2	3	35	75	6	
2JJCR 020 001 080	2 X R0.1	2	8	45	4		2JJCR 030 002 400	3 X R0.2	3	40	80	6	
2JJCR 020 001 100	2 X R0.1	2	10	50	4		2JJCR 030 003 100	3 X R0.3	3	10	50	6	
2JJCR 020 001 120	2 X R0.1	2	12	50	4		2JJCR 030 003 120	3 X R0.3	3	12	50	6	
2JJCR 020 001 140	2 X R0.1	2	14	50	4		2JJCR 030 003 160	3 X R0.3	3	16	55	6	
2JJCR 020 001 160	2 X R0.1	2	16	50	4		2JJCR 030 003 200	3 X R0.3	3	20	60	6	
2JJCR 020 001 200	2 X R0.1	2	20	50	4		2JJCR 030 003 250	3 X R0.3	3	25	65	6	
2JJCR 020 001 250	2 X R0.1	2	25	60	4		2JJCR 030 003 300	3 X R0.3	3	30	70	6	
2JJCR 020 001 300	2 X R0.1	2	30	70	4		2JJCR 030 003 350	3 X R0.3	3	35	75	6	
2JJCR 020 002 060	2 X R0.2	2	6	45	4		2JJCR 030 003 400	3 X R0.3	3	40	80	6	
2JJCR 020 002 080	2 X R0.2	2	8	45	4		2JJCR 030 005 100	3 X R0.5	3	10	50	6	
2JJCR 020 002 100	2 X R0.2	2	10	50	4		2JJCR 030 005 120	3 X R0.5	3	12	50	6	
2JJCR 020 002 120	2 X R0.2	2	12	50	4		2JJCR 030 005 160	3 X R0.5	3	16	55	6	
2JJCR 020 002 140	2 X R0.2	2	14	50	4		2JJCR 030 005 200	3 X R0.5	3	20	60	6	
2JJCR 020 002 160	2 X R0.2	2	16	50	4		2JJCR 030 005 250	3 X R0.5	3	25	65	6	
2JJCR 020 002 200	2 X R0.2	2	20	50	4		2JJCR 030 005 300	3 X R0.5	3	30	70	6	
2JJCR 020 002 250	2 X R0.2	2	25	60	4		2JJCR 030 005 350	3 X R0.5	3	35	75	6	
2JJCR 020 002 300	2 X R0.2	2	30	70	4		2JJCR 030 005 400	3 X R0.5	3	40	80	6	
2JJCR 020 003 060	2 X R0.3	2	6	45	4		2JJCR 030 010 100	3 X R1	3	10	50	6	
2JJCR 020 003 080	2 X R0.3	2	8	45	4		2JJCR 030 010 120	3 X R1	3	12	50	6	
2JJCR 020 003 100	2 X R0.3	2	10	50	4		2JJCR 030 010 160	3 X R1	3	16	55	6	
2JJCR 020 003 120	2 X R0.3	2	12	50	4		2JJCR 030 010 200	3 X R1	3	20	60	6	
2JJCR 020 003 140	2 X R0.3	2	14	50	4		2JJCR 030 010 250	3 X R1	3	25	65	6	
2JJCR 020 003 160	2 X R0.3	2	16	50	4		2JJCR 030 010 300	3 X R1	3	30	70	6	
2JJCR 020 003 200	2 X R0.3	2	20	50	4		2JJCR 030 010 350	3 X R1	3	35	75	6	
2JJCR 020 003 250	2 X R0.3	2	25	60	4		2JJCR 030 010 400	3 X R1	3	40	80	6	
2JJCR 020 003 300	2 X R0.3	2	30	70	4		2JJCR 040 001 120	4 X R0.1	4	12	50	6	
2JJCR 020 005 060	2 X R0.5	2	6	45	4		2JJCR 040 001 160	4 X R0.1	4	16	55	6	
2JJCR 020 005 080	2 X R0.5	2	8	45	4		2JJCR 040 001 200	4 X R0.1	4	20	60	6	
2JJCR 020 005 100	2 X R0.5	2	10	50	4		2JJCR 040 001 250	4 X R0.1	4	25	65	6	
2JJCR 020 005 120	2 X R0.5	2	12	50	4		2JJCR 040 001 300	4 X R0.1	4	30	70	6	
2JJCR 020 005 140	2 X R0.5	2	14	50	4		2JJCR 040 001 350	4 X R0.1	4	35	75	6	
2JJCR 020 005 160	2 X R0.5	2	16	50	4		2JJCR 040 001 400	4 X R0.1	4	40	80	6	
2JJCR 020 005 200	2 X R0.5	2	20	50	4		2JJCR 040 002 120	4 X R0.2	4	12	50	6	
2JJCR 020 005 250	2 X R0.5	2	25	60	4		2JJCR 040 002 160	4 X R0.2	4	16	55	6	
2JJCR 020 005 300	2 X R0.5	2	30	70	4		2JJCR 040 002 200	4 X R0.2	4	20	60	6	
2JJCR 025 001 100	2.5 X R0.1	2.5	10	50	4		2JJCR 040 002 250	4 X R0.2	4	25	65	6	
2JJCR 025 001 160	2.5 X R0.1	2.5	16	50	4		2JJCR 040 002 300	4 X R0.2	4	30	70	6	
2JJCR 025 001 200	2.5 X R0.1	2.5	20	50	4		2JJCR 040 002 350	4 X R0.2	4	35	75	6	
2JJCR 025 001 250	2.5 X R0.1	2.5	25	60	4		2JJCR 040 002 400	4 X R0.2	4	40	80	6	
2JJCR 025 001 300	2.5 X R0.1	2.5	30	70	4		2JJCR 040 003 120	4 X R0.3	4	12	50	6	
2JJCR 025 002 100	2.5 X R0.2	2.5	10	50	4		2JJCR 040 003 160	4 X R0.3	4	16	55	6	
2JJCR 025 002 160	2.5 X R0.2	2.5	16	50	4		2JJCR 040 003 200	4 X R0.3	4	20	60	6	

단위 : mm

Order Number	날경 Diameter D × R	날장 Length of cut L1	유효장 Effective Length L2	전장 Overall Length L	샙크 Dia d	비고	Order Number	날경 Diameter D × R	날장 Length of cut L1	유효장 Effective Length L2	전장 Overall Length L	샙크 Dia d	비고
2JJCR 040 003 250	4 X R0.3	4	25	65	6								
2JJCR 040 003 300	4 X R0.3	4	30	70	6								
2JJCR 040 003 350	4 X R0.3	4	35	75	6								
2JJCR 040 003 400	4 X R0.3	4	40	80	6								
2JJCR 040 005 120	4 X R0.5	4	12	50	6								
2JJCR 040 005 160	4 X R0.5	4	16	55	6								
2JJCR 040 005 200	4 X R0.5	4	20	60	6								
2JJCR 040 005 250	4 X R0.5	4	25	65	6								
2JJCR 040 005 300	4 X R0.5	4	30	70	6								
2JJCR 040 005 350	4 X R0.5	4	35	75	6								
2JJCR 040 005 400	4 X R0.5	4	40	80	6								
2JJCR 040 010 120	4 X R1	4	12	50	6								
2JJCR 040 010 160	4 X R1	4	16	55	6								
2JJCR 040 010 200	4 X R1	4	20	60	6								
2JJCR 040 010 250	4 X R1	4	25	65	6								
2JJCR 040 010 300	4 X R1	4	30	70	6								
2JJCR 040 010 350	4 X R1	4	35	75	6								
2JJCR 040 010 400	4 X R1	4	40	80	6								
2JJCR 050 002 150	5 X R0.2	6	15	60	6								
2JJCR 050 002 250	5 X R0.2	6	25	70	6								
2JJCR 050 002 300	5 X R0.2	6	30	70	6								
2JJCR 050 002 400	5 X R0.2	6	40	80	6								
2JJCR 050 005 150	5 X R0.5	6	15	60	6								
2JJCR 050 005 250	5 X R0.5	6	25	70	6								
2JJCR 050 005 300	5 X R0.5	6	30	70	6								
2JJCR 050 005 400	5 X R0.5	6	40	80	6								
2JJCR 050 010 150	5 X R1	6	15	60	6								
2JJCR 050 010 250	5 X R1	6	25	70	6								
2JJCR 050 010 300	5 X R1	6	30	70	6								
2JJCR 050 010 400	5 X R1	6	40	80	6								
2JJCR 060 001 200	6 X R0.1	7	20	60	6								
2JJCR 060 001 400	6 X R0.1	7	40	80	6								
2JJCR 060 002 200	6 X R0.2	7	20	60	6								
2JJCR 060 002 400	6 X R0.2	7	40	80	6								
2JJCR 060 003 200	6 X R0.3	7	20	60	6								
2JJCR 060 003 400	6 X R0.3	7	40	80	6								
2JJCR 060 005 200	6 X R0.5	7	20	60	6								
2JJCR 060 005 400	6 X R0.5	7	40	80	6								
2JJCR 060 010 200	6 X R1	7	20	60	6								
2JJCR 060 010 400	6 X R1	7	40	80	6								
2JJCR 060 015 200	6 X R1.5	7	20	60	6								
2JJCR 060 015 400	6 X R1.5	7	40	80	6								
2JJCR 080 002 220	8 X R0.2	9	22	65	8								
2JJCR 080 003 220	8 X R0.3	9	22	65	8								
2JJCR 080 005 220	8 X R0.5	9	22	65	8								
2JJCR 080 010 220	8 X R1	9	22	65	8								
2JJCR 080 015 220	8 X R1.5	9	22	65	8								
2JJCR 100 002 240	10 X R0.2	11	24	70	10								
2JJCR 100 003 240	10 X R0.3	11	24	70	10								
2JJCR 100 005 240	10 X R0.5	11	24	70	10								
2JJCR 100 010 240	10 X R1	11	24	70	10								
2JJCR 100 015 240	10 X R1.5	11	24	70	10								
2JJCR 100 020 240	10 X R2	11	24	70	10								
2JJCR 120 002 260	12 X R0.2	13	26	80	12								
2JJCR 120 003 260	12 X R0.3	13	26	80	12								
2JJCR 120 005 260	12 X R0.5	13	26	80	12								
2JJCR 120 010 260	12 X R1	13	26	80	12								
2JJCR 120 015 260	12 X R1.5	13	26	80	12								
2JJCR 120 020 260	12 X R2	13	26	80	12								
2JJCR 120 030 260	12 X R3	13	26	80	12								
2JJCR 160 005 110	16 X R0.5	20	35	110	16								
2JJCR 160 010 110	16 X R1	20	35	110	16								



2날 고정도재 가공용 제이제이 테이퍼 넥 코너 레디우스 엔드밀

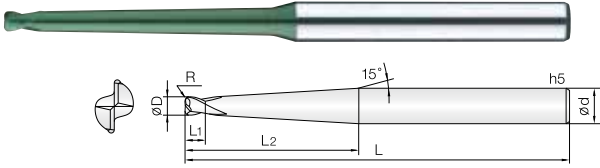

- 고정도강(HRc52~68), 프리하드강 계열의 고정밀 가공 엔드밀
- 고품량 실리콘계 코팅(Si) 처리하여 내마모성이 우수합니다.
- 유효장을 테이퍼 설계하여 깊은 홈 작업시 목부파손 및 떨림을 최소화 하였습니다.
- 코너R 형상을 날부치핑이 적도록 설계하였습니다.
- 고정밀 공차 적용으로 초정밀 가공에 적합합니다.
- 초미립자 초경합금(0.2µm)을 채택, 고속절삭시 뛰어난 성능을 발휘합니다.

• Endmills for pre-hardened and hardened steels(HRc52~68)

- Good wear resistance by high quality Si-based PVD coating.
- Minimize chattering and fracturing by taper designed flute.
- Designed for minimizing edge chipping by corner R shape.
- High precise edge tolerance.
- Outstanding performance at high speed machining by ultra fine (0.2µm) WC grade.

Condition	D Size	D Tolerance
ØD ≠ Ød	Ø1 ~ 4	+0 ~ -0.01mm

Order Number	날경 D×R	각도 θ	날장 Length of cut L1	유효장 Effective Length L2	전장 Overall Length L	샤프크 Shank Dia d	비고	Order Number	날경 D×R	각도 θ	날장 Length of cut L1	유효장 Effective Length L2	전장 Overall Length L	샤프크 Shank Dia d	비고
2JJTC 010 001 0601	1 X R0.1	1°	1	6	50	4		2JJTC 020 003 2501	2 X R0.3	1°	2	25	60	4	
2JJTC 010 001 1001	1 X R0.1	1°	1	10	50	4		2JJTC 020 003 3001	2 X R0.3	1°	2	30	70	4	
2JJTC 010 001 1501	1 X R0.1	1°	1	15	50	4		2JJTC 020 003 3501	2 X R0.3	1°	2	35	75	4	
2JJTC 010 001 2001	1 X R0.1	1°	1	20	60	4		2JJTC 020 003 4001	2 X R0.3	1°	2	40	80	4	
2JJTC 010 001 2501	1 X R0.1	1°	1	25	60	4		2JJTC 020 003 5001	2 X R0.3	1°	2	50	90	4	
2JJTC 010 001 3001	1 X R0.1	1°	1	30	70	4		2JJTC 020 005 1201	2 X R0.5	1°	2	12	50	4	
2JJTC 010 001 3501	1 X R0.1	1°	1	35	75	4		2JJTC 020 005 1601	2 X R0.5	1°	2	16	50	4	
2JJTC 010 002 0601	1 X R0.2	1°	1	6	50	4		2JJTC 020 005 2001	2 X R0.5	1°	2	20	60	4	
2JJTC 010 002 1001	1 X R0.2	1°	1	10	50	4		2JJTC 020 005 2501	2 X R0.5	1°	2	25	60	4	
2JJTC 010 002 1501	1 X R0.2	1°	1	15	50	4		2JJTC 020 005 3001	2 X R0.5	1°	2	30	70	4	
2JJTC 010 002 2001	1 X R0.2	1°	1	20	60	4		2JJTC 020 005 3501	2 X R0.5	1°	2	35	75	4	
2JJTC 010 002 2501	1 X R0.2	1°	1	25	60	4		2JJTC 020 005 4001	2 X R0.5	1°	2	40	80	4	
2JJTC 010 002 3001	1 X R0.2	1°	1	30	70	4		2JJTC 020 005 5001	2 X R0.5	1°	2	50	90	4	
2JJTC 010 002 3501	1 X R0.2	1°	1	35	75	4		2JJTC 030 002 2001	3 X R0.2	1°	3	20	60	6	
2JJTC 010 003 0601	1 X R0.3	1°	1	6	50	4		2JJTC 030 002 3001	3 X R0.2	1°	3	30	70	6	
2JJTC 010 003 1001	1 X R0.3	1°	1	10	50	4		2JJTC 030 002 4001	3 X R0.2	1°	3	40	80	6	
2JJTC 010 003 1501	1 X R0.3	1°	1	15	50	4		2JJTC 030 002 5001	3 X R0.2	1°	3	50	90	6	
2JJTC 010 003 2001	1 X R0.3	1°	1	20	60	4		2JJTC 030 002 6001	3 X R0.2	1°	3	60	100	6	
2JJTC 010 003 2501	1 X R0.3	1°	1	25	60	4		2JJTC 030 003 2001	3 X R0.3	1°	3	20	60	6	
2JJTC 010 003 3001	1 X R0.3	1°	1	30	70	4		2JJTC 030 003 3001	3 X R0.3	1°	3	30	70	6	
2JJTC 010 003 3501	1 X R0.3	1°	1	35	75	4		2JJTC 030 003 4001	3 X R0.3	1°	3	40	80	6	
2JJTC 015 002 1001	1.5 X R0.2	1°	1.5	10	50	4		2JJTC 030 003 5001	3 X R0.3	1°	3	50	90	6	
2JJTC 015 002 1501	1.5 X R0.2	1°	1.5	15	50	4		2JJTC 030 003 6001	3 X R0.3	1°	3	60	100	6	
2JJTC 015 002 2001	1.5 X R0.2	1°	1.5	20	60	4		2JJTC 030 005 2001	3 X R0.5	1°	3	20	60	6	
2JJTC 015 002 2501	1.5 X R0.2	1°	1.5	25	60	4		2JJTC 030 005 3001	3 X R0.5	1°	3	30	70	6	
2JJTC 015 002 3001	1.5 X R0.2	1°	1.5	30	70	4		2JJTC 030 005 4001	3 X R0.5	1°	3	40	80	6	
2JJTC 015 002 3501	1.5 X R0.2	1°	1.5	35	75	4		2JJTC 030 005 5001	3 X R0.5	1°	3	50	90	6	
2JJTC 015 003 1001	1.5 X R0.3	1°	1.5	10	50	4		2JJTC 030 005 6001	3 X R0.5	1°	3	60	100	6	
2JJTC 015 003 1501	1.5 X R0.3	1°	1.5	15	50	4		2JJTC 030 010 2001	3 X R1	1°	3	20	60	6	
2JJTC 015 003 2001	1.5 X R0.3	1°	1.5	20	60	4		2JJTC 030 010 3001	3 X R1	1°	3	30	70	6	
2JJTC 015 003 2501	1.5 X R0.3	1°	1.5	25	60	4		2JJTC 030 010 4001	3 X R1	1°	3	40	80	6	
2JJTC 015 003 3001	1.5 X R0.3	1°	1.5	30	70	4		2JJTC 030 010 5001	3 X R1	1°	3	50	90	6	
2JJTC 015 003 3501	1.5 X R0.3	1°	1.5	35	75	4		2JJTC 030 010 6001	3 X R1	1°	3	60	100	6	
2JJTC 015 005 1001	1.5 X R0.5	1°	1.5	10	50	4		2JJTC 040 002 2001	4 X R0.2	1°	4	20	60	6	
2JJTC 015 005 1501	1.5 X R0.5	1°	1.5	15	50	4		2JJTC 040 002 3001	4 X R0.2	1°	4	30	70	6	
2JJTC 015 005 2001	1.5 X R0.5	1°	1.5	20	60	4		2JJTC 040 002 4001	4 X R0.2	1°	4	40	80	6	
2JJTC 015 005 2501	1.5 X R0.5	1°	1.5	25	60	4		2JJTC 040 002 5001	4 X R0.2	1°	4	50	90	6	
2JJTC 015 005 3001	1.5 X R0.5	1°	1.5	30	70	4		2JJTC 040 002 6001	4 X R0.2	1°	4	60	100	6	
2JJTC 015 005 3501	1.5 X R0.5	1°	1.5	35	75	4		2JJTC 040 003 2001	4 X R0.3	1°	4	20	60	6	
2JJTC 020 002 1201	2 X R0.2	1°	2	12	50	4		2JJTC 040 003 3001	4 X R0.3	1°	4	30	70	6	
2JJTC 020 002 1601	2 X R0.2	1°	2	16	50	4		2JJTC 040 003 4001	4 X R0.3	1°	4	40	80	6	
2JJTC 020 002 2001	2 X R0.2	1°	2	20	60	4		2JJTC 040 003 5001	4 X R0.3	1°	4	50	90	6	
2JJTC 020 002 2501	2 X R0.2	1°	2	25	60	4		2JJTC 040 003 6001	4 X R0.3	1°	4	60	100	6	
2JJTC 020 002 3001	2 X R0.2	1°	2	30	70	4		2JJTC 040 005 2001	4 X R0.5	1°	4	20	60	6	
2JJTC 020 002 3501	2 X R0.2	1°	2	35	75	4		2JJTC 040 005 3001	4 X R0.5	1°	4	30	70	6	
2JJTC 020 002 4001	2 X R0.2	1°	2	40	80	4		2JJTC 040 005 4001	4 X R0.5	1°	4	40	80	6	
2JJTC 020 002 5001	2 X R0.2	1°	2	50	90	4		2JJTC 040 005 5001	4 X R0.5	1°	4	50	90	6	
2JJTC 020 003 1201	2 X R0.3	1°	2	12	50	4		2JJTC 040 005 6001	4 X R0.5	1°	4	60	100	6	
2JJTC 020 003 1601	2 X R0.3	1°	2	16	50	4		2JJTC 040 010 2001	4 X R1	1°	4	20	60	6	
2JJTC 020 003 2001	2 X R0.3	1°	2	20	60	4		2JJTC 040 010 3001	4 X R1	1°	4	30	70	6	

단위: mm

Order Number	날경 Diameter D×R	각도 Angle θ	날장 Length of cut L1	유효장 Effective Length L2	전장 Overall Length L	샙크 Dia d	비고
2JJTC 040 010 4001	4 X R1	1°	4	40	80	6	
2JJTC 040 010 5001	4 X R1	1°	4	50	90	6	
2JJTC 040 010 6001	4 X R1	1°	4	60	100	6	

Order Number	날경 Diameter D×R	각도 Angle θ	날장 Length of cut L1	유효장 Effective Length L2	전장 Overall Length L	샙크 Dia d	비고

### 4날 고정도재 가공용 제이제이 리브 코너 레디우스 엔드밀

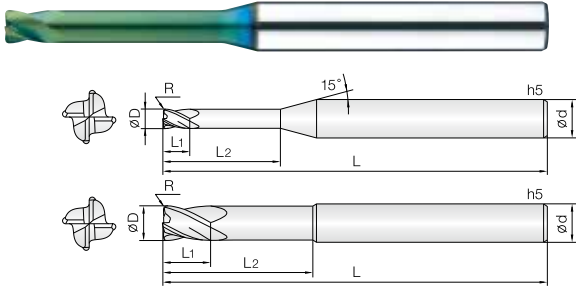

- 고정도강(HRc52~68), 프리하든강 계열의 고정밀 가공 엔드밀
- 고품량 실리콘계 코팅(Si) 처리하여 내마모성이 우수합니다.
- 고정밀 공차 적용으로 초정밀 가공에 적합합니다.
- 코너R 형상을 날부치평이 적도록 설계하였습니다.
- 다양한 코너R과 유효장으로 맞춤 가공이 가능합니다.
- 초미립자 초경합금(0.2µm)을 채택, 고속절삭시 뛰어난 성능을 발휘합니다.

#### • Endmills for pre-hardened and hardened steels(HRc52~68)

- Good wear resistance by high quality Si-based PVD coating.
- High precise edge tolerance.
- Designed for minimizing edge chipping by corner R shape.
- Various corner R and flute length for wide range application.
- Outstanding performance at high speed machining by ultra fine (0.2µm) WC grade.

4

UWC  
초미립자

TISIN-S  
Coating

R  
±0.005

R  
±0.01

R  
±0.015

30°  
Helix Angle

CUTTING  
DATA

R0.02 ~ 0.5    R1 ~ 1.5    R2 ~ 3    416P

Condition	D Size	D Tolerance	Condition	D Size	D Tolerance
øD ≠ ød	ø0.5 ~ 12	+0 ~ -0.01mm	øD = ød	ø6 ~ 12	-0.005 ~ -0.015mm

Order Number	날경 Diameter D×R	날장 Length of cut L1	유효장 Effective Length L2	전장 Overall Length L	샹크 Shank Dia d	비고	단위 : mm						
							Order Number	날경 Diameter D×R	날장 Length of cut L1	유효장 Effective Length L2	전장 Overall Length L	샹크 Shank Dia d	비고
4JJCR 005 0005 020	0.5 X R0.05	0.5	2	45	4		4JJCR 010 0005 040	1 X R0.05	1	4	45	4	
4JJCR 005 0005 040	0.5 X R0.05	0.5	4	45	4		4JJCR 010 0005 060	1 X R0.05	1	6	45	4	
4JJCR 005 0005 060	0.5 X R0.05	0.5	6	45	4		4JJCR 010 0005 080	1 X R0.05	1	8	45	4	
4JJCR 005 0005 080	0.5 X R0.05	0.5	8	45	4		4JJCR 010 0005 100	1 X R0.05	1	10	50	4	
4JJCR 005 001 020	0.5 X R0.1	0.5	2	45	4		4JJCR 010 0005 120	1 X R0.05	1	12	50	4	
4JJCR 005 001 040	0.5 X R0.1	0.5	4	45	4		4JJCR 010 0005 140	1 X R0.05	1	14	50	4	
4JJCR 005 001 060	0.5 X R0.1	0.5	6	45	4		4JJCR 010 0005 160	1 X R0.05	1	16	50	4	
4JJCR 005 001 080	0.5 X R0.1	0.5	8	45	4		4JJCR 010 0005 200	1 X R0.05	1	20	50	4	
4JJCR 006 0005 020	0.6 X R0.05	0.6	2	45	4		4JJCR 010 001 040	1 X R0.1	1	4	45	4	
4JJCR 006 0005 040	0.6 X R0.05	0.6	4	45	4		4JJCR 010 001 060	1 X R0.1	1	6	45	4	
4JJCR 006 0005 060	0.6 X R0.05	0.6	6	45	4		4JJCR 010 001 080	1 X R0.1	1	8	45	4	
4JJCR 006 0005 080	0.6 X R0.05	0.6	8	45	4		4JJCR 010 001 100	1 X R0.1	1	10	50	4	
4JJCR 006 001 020	0.6 X R0.1	0.6	2	45	4		4JJCR 010 001 120	1 X R0.1	1	12	50	4	
4JJCR 006 001 040	0.6 X R0.1	0.6	4	45	4		4JJCR 010 001 140	1 X R0.1	1	14	50	4	
4JJCR 006 001 060	0.6 X R0.1	0.6	6	45	4		4JJCR 010 001 160	1 X R0.1	1	16	50	4	
4JJCR 006 001 080	0.6 X R0.1	0.6	8	45	4		4JJCR 010 001 200	1 X R0.1	1	20	50	4	
4JJCR 007 0005 020	0.7 X R0.05	0.7	2	45	4		4JJCR 010 002 040	1 X R0.2	1	4	45	4	
4JJCR 007 0005 040	0.7 X R0.05	0.7	4	45	4		4JJCR 010 002 060	1 X R0.2	1	6	45	4	
4JJCR 007 0005 060	0.7 X R0.05	0.7	6	45	4		4JJCR 010 002 080	1 X R0.2	1	8	45	4	
4JJCR 007 0005 080	0.7 X R0.05	0.7	8	45	4		4JJCR 010 002 100	1 X R0.2	1	10	50	4	
4JJCR 007 001 020	0.7 X R0.1	0.7	2	45	4		4JJCR 010 002 120	1 X R0.2	1	12	50	4	
4JJCR 007 001 040	0.7 X R0.1	0.7	4	45	4		4JJCR 010 002 140	1 X R0.2	1	14	50	4	
4JJCR 007 001 060	0.7 X R0.1	0.7	6	45	4		4JJCR 010 002 160	1 X R0.2	1	16	50	4	
4JJCR 007 001 080	0.7 X R0.1	0.7	8	45	4		4JJCR 010 002 200	1 X R0.2	1	20	50	4	
4JJCR 008 0002 020	0.8 X R0.02	0.8	2	45	4		4JJCR 010 003 040	1 X R0.3	1	4	45	4	
4JJCR 008 0002 040	0.8 X R0.02	0.8	4	45	4		4JJCR 010 003 060	1 X R0.3	1	6	45	4	
4JJCR 008 0002 060	0.8 X R0.02	0.8	6	45	4		4JJCR 010 003 080	1 X R0.3	1	8	45	4	
4JJCR 008 0002 080	0.8 X R0.02	0.8	8	45	4		4JJCR 010 003 100	1 X R0.3	1	10	50	4	
4JJCR 008 0002 100	0.8 X R0.02	0.8	10	45	4		4JJCR 010 003 120	1 X R0.3	1	12	50	4	
4JJCR 008 0002 120	0.8 X R0.02	0.8	12	50	4		4JJCR 010 003 140	1 X R0.3	1	14	50	4	
4JJCR 008 0005 020	0.8 X R0.05	0.8	2	45	4		4JJCR 010 003 160	1 X R0.3	1	16	50	4	
4JJCR 008 0005 040	0.8 X R0.05	0.8	4	45	4		4JJCR 010 003 200	1 X R0.3	1	20	50	4	
4JJCR 008 0005 060	0.8 X R0.05	0.8	6	45	4		4JJCR 012 0002 040	1.2 X R0.02	1.2	4	45	4	
4JJCR 008 0005 080	0.8 X R0.05	0.8	8	45	4		4JJCR 012 0002 060	1.2 X R0.02	1.2	6	45	4	
4JJCR 008 0005 100	0.8 X R0.05	0.8	10	45	4		4JJCR 012 0002 080	1.2 X R0.02	1.2	8	45	4	
4JJCR 008 0005 120	0.8 X R0.05	0.8	12	50	4		4JJCR 012 0002 100	1.2 X R0.02	1.2	10	50	4	
4JJCR 008 001 020	0.8 X R0.1	0.8	2	45	4		4JJCR 012 0002 120	1.2 X R0.02	1.2	12	50	4	
4JJCR 008 001 040	0.8 X R0.1	0.8	4	45	4		4JJCR 012 0002 140	1.2 X R0.02	1.2	14	50	4	
4JJCR 008 001 060	0.8 X R0.1	0.8	6	45	4		4JJCR 012 0002 160	1.2 X R0.02	1.2	16	50	4	
4JJCR 008 001 080	0.8 X R0.1	0.8	8	45	4		4JJCR 012 0002 200	1.2 X R0.02	1.2	20	50	4	
4JJCR 008 001 100	0.8 X R0.1	0.8	10	45	4		4JJCR 012 0005 040	1.2 X R0.05	1.2	4	45	4	
4JJCR 008 001 120	0.8 X R0.1	0.8	12	50	4		4JJCR 012 0005 060	1.2 X R0.05	1.2	6	45	4	
4JJCR 010 0002 040	1 X R0.02	1	4	45	4		4JJCR 012 0005 080	1.2 X R0.05	1.2	8	45	4	
4JJCR 010 0002 060	1 X R0.02	1	6	45	4		4JJCR 012 0005 100	1.2 X R0.05	1.2	10	50	4	
4JJCR 010 0002 080	1 X R0.02	1	8	45	4		4JJCR 012 0005 120	1.2 X R0.05	1.2	12	50	4	
4JJCR 010 0002 100	1 X R0.02	1	10	50	4		4JJCR 012 0005 140	1.2 X R0.05	1.2	14	50	4	
4JJCR 010 0002 120	1 X R0.02	1	12	50	4		4JJCR 012 0005 160	1.2 X R0.05	1.2	16	50	4	
4JJCR 010 0002 140	1 X R0.02	1	14	50	4		4JJCR 012 0005 200	1.2 X R0.05	1.2	20	50	4	
4JJCR 010 0002 160	1 X R0.02	1	16	50	4		4JJCR 012 001 040	1.2 X R0.1	1.2	4	45	4	
4JJCR 010 0002 200	1 X R0.02	1	20	50	4		4JJCR 012 001 060	1.2 X R0.1	1.2	6	45	4	

단위 : mm

Order Number	날경 D×R	날장 Length of cut L1	유효장 Effective Length L2	전장 Overall Length L	샙크 Dia d	비고	Order Number	날경 D×R	날장 Length of cut L1	유효장 Effective Length L2	전장 Overall Length L	샙크 Dia d	비고
4JJCR 012 001 080	1.2 X R0.1	1.2	8	45	4		4JJCR 015 005 120	1.5 X R0.5	1.5	12	50	4	
4JJCR 012 001 100	1.2 X R0.1	1.2	10	50	4		4JJCR 015 005 140	1.5 X R0.5	1.5	14	50	4	
4JJCR 012 001 120	1.2 X R0.1	1.2	12	50	4		4JJCR 015 005 160	1.5 X R0.5	1.5	16	50	4	
4JJCR 012 001 140	1.2 X R0.1	1.2	14	50	4		4JJCR 015 005 200	1.5 X R0.5	1.5	20	50	4	
4JJCR 012 001 160	1.2 X R0.1	1.2	16	50	4		4JJCR 015 005 220	1.5 X R0.5	1.5	22	60	4	
4JJCR 012 001 200	1.2 X R0.1	1.2	20	50	4		4JJCR 015 005 250	1.5 X R0.5	1.5	25	60	4	
4JJCR 012 002 040	1.2 X R0.2	1.2	4	45	4		4JJCR 020 0002 060	2 X R0.02	2	6	45	4	
4JJCR 012 002 060	1.2 X R0.2	1.2	6	45	4		4JJCR 020 0002 080	2 X R0.02	2	8	45	4	
4JJCR 012 002 080	1.2 X R0.2	1.2	8	45	4		4JJCR 020 0002 100	2 X R0.02	2	10	50	4	
4JJCR 012 002 100	1.2 X R0.2	1.2	10	50	4		4JJCR 020 0002 120	2 X R0.02	2	12	50	4	
4JJCR 012 002 120	1.2 X R0.2	1.2	12	50	4		4JJCR 020 0002 140	2 X R0.02	2	14	50	4	
4JJCR 012 002 140	1.2 X R0.2	1.2	14	50	4		4JJCR 020 0002 160	2 X R0.02	2	16	50	4	
4JJCR 012 002 160	1.2 X R0.2	1.2	16	50	4		4JJCR 020 0002 200	2 X R0.02	2	20	50	4	
4JJCR 012 002 200	1.2 X R0.2	1.2	20	50	4		4JJCR 020 0002 250	2 X R0.02	2	25	60	4	
4JJCR 012 003 040	1.2 X R0.3	1.2	4	45	4		4JJCR 020 0002 300	2 X R0.02	2	30	70	4	
4JJCR 012 003 060	1.2 X R0.3	1.2	6	45	4		4JJCR 020 0005 060	2 X R0.05	2	6	45	4	
4JJCR 012 003 080	1.2 X R0.3	1.2	8	45	4		4JJCR 020 0005 080	2 X R0.05	2	8	45	4	
4JJCR 012 003 100	1.2 X R0.3	1.2	10	50	4		4JJCR 020 0005 100	2 X R0.05	2	10	50	4	
4JJCR 012 003 120	1.2 X R0.3	1.2	12	50	4		4JJCR 020 0005 120	2 X R0.05	2	12	50	4	
4JJCR 015 0002 060	1.5 X R0.02	1.5	6	45	4		4JJCR 020 0005 140	2 X R0.05	2	14	50	4	
4JJCR 015 0002 080	1.5 X R0.02	1.5	8	45	4		4JJCR 020 0005 160	2 X R0.05	2	16	50	4	
4JJCR 015 0002 100	1.5 X R0.02	1.5	10	50	4		4JJCR 020 0005 200	2 X R0.05	2	20	50	4	
4JJCR 015 0002 120	1.5 X R0.02	1.5	12	50	4		4JJCR 020 0005 250	2 X R0.05	2	25	60	4	
4JJCR 015 0002 140	1.5 X R0.02	1.5	14	50	4		4JJCR 020 0005 300	2 X R0.05	2	30	70	4	
4JJCR 015 0002 160	1.5 X R0.02	1.5	16	50	4		4JJCR 020 001 060	2 X R0.1	2	6	45	4	
4JJCR 015 0002 200	1.5 X R0.02	1.5	20	50	4		4JJCR 020 001 080	2 X R0.1	2	8	45	4	
4JJCR 015 0002 220	1.5 X R0.02	1.5	22	60	4		4JJCR 020 001 100	2 X R0.1	2	10	50	4	
4JJCR 015 0005 060	1.5 X R0.05	1.5	6	45	4		4JJCR 020 001 120	2 X R0.1	2	12	50	4	
4JJCR 015 0005 080	1.5 X R0.05	1.5	8	45	4		4JJCR 020 001 140	2 X R0.1	2	14	50	4	
4JJCR 015 0005 100	1.5 X R0.05	1.5	10	50	4		4JJCR 020 001 160	2 X R0.1	2	16	50	4	
4JJCR 015 0005 120	1.5 X R0.05	1.5	12	50	4		4JJCR 020 001 200	2 X R0.1	2	20	50	4	
4JJCR 015 0005 140	1.5 X R0.05	1.5	14	50	4		4JJCR 020 001 250	2 X R0.1	2	25	60	4	
4JJCR 015 0005 160	1.5 X R0.05	1.5	16	50	4		4JJCR 020 001 300	2 X R0.1	2	30	70	4	
4JJCR 015 0005 200	1.5 X R0.05	1.5	20	50	4		4JJCR 020 002 060	2 X R0.2	2	6	45	4	
4JJCR 015 0005 220	1.5 X R0.05	1.5	22	60	4		4JJCR 020 002 080	2 X R0.2	2	8	45	4	
4JJCR 015 001 060	1.5 X R0.1	1.5	6	45	4		4JJCR 020 002 100	2 X R0.2	2	10	50	4	
4JJCR 015 001 080	1.5 X R0.1	1.5	8	45	4		4JJCR 020 002 120	2 X R0.2	2	12	50	4	
4JJCR 015 001 100	1.5 X R0.1	1.5	10	50	4		4JJCR 020 002 140	2 X R0.2	2	14	50	4	
4JJCR 015 001 120	1.5 X R0.1	1.5	12	50	4		4JJCR 020 002 160	2 X R0.2	2	16	50	4	
4JJCR 015 001 140	1.5 X R0.1	1.5	14	50	4		4JJCR 020 002 200	2 X R0.2	2	20	50	4	
4JJCR 015 001 160	1.5 X R0.1	1.5	16	50	4		4JJCR 020 002 250	2 X R0.2	2	25	60	4	
4JJCR 015 001 200	1.5 X R0.1	1.5	20	50	4		4JJCR 020 002 300	2 X R0.2	2	30	70	4	
4JJCR 015 001 220	1.5 X R0.1	1.5	22	60	4		4JJCR 020 003 060	2 X R0.3	2	6	45	4	
4JJCR 015 002 060	1.5 X R0.2	1.5	6	45	4		4JJCR 020 003 080	2 X R0.3	2	8	45	4	
4JJCR 015 002 080	1.5 X R0.2	1.5	8	45	4		4JJCR 020 003 100	2 X R0.3	2	10	50	4	
4JJCR 015 002 100	1.5 X R0.2	1.5	10	50	4		4JJCR 020 003 120	2 X R0.3	2	12	50	4	
4JJCR 015 002 120	1.5 X R0.2	1.5	12	50	4		4JJCR 020 003 140	2 X R0.3	2	14	50	4	
4JJCR 015 002 140	1.5 X R0.2	1.5	14	50	4		4JJCR 020 003 160	2 X R0.3	2	16	50	4	
4JJCR 015 002 160	1.5 X R0.2	1.5	16	50	4		4JJCR 020 003 200	2 X R0.3	2	20	50	4	
4JJCR 015 002 200	1.5 X R0.2	1.5	20	50	4		4JJCR 020 003 250	2 X R0.3	2	25	60	4	
4JJCR 015 002 220	1.5 X R0.2	1.5	22	60	4		4JJCR 020 003 300	2 X R0.3	2	30	70	4	
4JJCR 015 002 250	1.5 X R0.2	1.5	25	60	4		4JJCR 020 005 060	2 X R0.5	2	6	45	4	
4JJCR 015 003 060	1.5 X R0.3	1.5	6	45	4		4JJCR 020 005 080	2 X R0.5	2	8	45	4	
4JJCR 015 003 080	1.5 X R0.3	1.5	8	45	4		4JJCR 020 005 100	2 X R0.5	2	10	50	4	
4JJCR 015 003 100	1.5 X R0.3	1.5	10	50	4		4JJCR 020 005 120	2 X R0.5	2	12	50	4	
4JJCR 015 003 120	1.5 X R0.3	1.5	12	50	4		4JJCR 020 005 140	2 X R0.5	2	14	50	4	
4JJCR 015 003 140	1.5 X R0.3	1.5	14	50	4		4JJCR 020 005 160	2 X R0.5	2	16	50	4	
4JJCR 015 003 160	1.5 X R0.3	1.5	16	50	4		4JJCR 020 005 200	2 X R0.5	2	20	50	4	
4JJCR 015 003 200	1.5 X R0.3	1.5	20	50	4		4JJCR 020 005 250	2 X R0.5	2	25	60	4	
4JJCR 015 003 220	1.5 X R0.3	1.5	22	60	4		4JJCR 020 005 300	2 X R0.5	2	30	70	4	
4JJCR 015 003 250	1.5 X R0.3	1.5	25	60	4		4JJCR 025 001 100	2.5 X R0.1	2.5	10	50	4	
4JJCR 015 005 060	1.5 X R0.5	1.5	6	45	4		4JJCR 025 001 160	2.5 X R0.1	2.5	16	50	4	
4JJCR 015 005 080	1.5 X R0.5	1.5	8	45	4		4JJCR 025 001 200	2.5 X R0.1	2.5	20	50	4	
4JJCR 015 005 100	1.5 X R0.5	1.5	10	50	4		4JJCR 025 001 250	2.5 X R0.1	2.5	25	60	4	

단위 : mm

Order Number	날경 Diameter D×R	날장 Length of cut L1	유효장 Effective Length L2	전장 Overall Length L	생크 Shank Dia d	비고	Order Number	날경 Diameter D×R	날장 Length of cut L1	유효장 Effective Length L2	전장 Overall Length L	생크 Shank Dia d	비고
4JJCR 025 001 300	2.5 X R0.1	2.5	30	70	4		4JJCR 040 001 160	4 X R0.1	4	16	55	6	
4JJCR 025 002 100	2.5 X R0.2	2.5	10	50	4		4JJCR 040 001 200	4 X R0.1	4	20	60	6	
4JJCR 025 002 160	2.5 X R0.2	2.5	16	50	4		4JJCR 040 001 250	4 X R0.1	4	25	65	6	
4JJCR 025 002 200	2.5 X R0.2	2.5	20	50	4		4JJCR 040 001 300	4 X R0.1	4	30	70	6	
4JJCR 025 002 250	2.5 X R0.2	2.5	25	60	4		4JJCR 040 001 350	4 X R0.1	4	35	75	6	
4JJCR 025 002 300	2.5 X R0.2	2.5	30	70	4		4JJCR 040 001 400	4 X R0.1	4	40	80	6	
4JJCR 025 003 100	2.5 X R0.3	2.5	10	50	4		4JJCR 040 002 130	4 X R0.2	4	13	55	6	
4JJCR 025 003 160	2.5 X R0.3	2.5	16	50	4		4JJCR 040 002 160	4 X R0.2	4	16	55	6	
4JJCR 025 003 200	2.5 X R0.3	2.5	20	50	4		4JJCR 040 002 200	4 X R0.2	4	20	60	6	
4JJCR 025 003 250	2.5 X R0.3	2.5	25	60	4		4JJCR 040 002 250	4 X R0.2	4	25	65	6	
4JJCR 025 003 300	2.5 X R0.3	2.5	30	70	4		4JJCR 040 002 300	4 X R0.2	4	30	70	6	
4JJCR 025 005 100	2.5 X R0.5	2.5	10	50	4		4JJCR 040 002 350	4 X R0.2	4	35	75	6	
4JJCR 025 005 160	2.5 X R0.5	2.5	16	50	4		4JJCR 040 002 400	4 X R0.2	4	40	80	6	
4JJCR 025 005 200	2.5 X R0.5	2.5	20	50	4		4JJCR 040 002 450	4 X R0.2	4	45	90	6	
4JJCR 025 005 250	2.5 X R0.5	2.5	25	60	4		4JJCR 040 002 500	4 X R0.2	4	50	100	6	
4JJCR 025 005 300	2.5 X R0.5	2.5	30	70	4		4JJCR 040 003 130	4 X R0.3	4	13	55	6	
4JJCR 030 001 100	3 X R0.1	3	10	50	6		4JJCR 040 003 160	4 X R0.3	4	16	55	6	
4JJCR 030 001 120	3 X R0.1	3	12	50	6		4JJCR 040 003 200	4 X R0.3	4	20	60	6	
4JJCR 030 001 160	3 X R0.1	3	16	55	6		4JJCR 040 003 250	4 X R0.3	4	25	65	6	
4JJCR 030 001 200	3 X R0.1	3	20	60	6		4JJCR 040 003 300	4 X R0.3	4	30	70	6	
4JJCR 030 001 250	3 X R0.1	3	25	65	6		4JJCR 040 003 350	4 X R0.3	4	35	75	6	
4JJCR 030 001 300	3 X R0.1	3	30	70	6		4JJCR 040 003 400	4 X R0.3	4	40	80	6	
4JJCR 030 001 350	3 X R0.1	3	35	75	6		4JJCR 040 003 450	4 X R0.3	4	45	90	6	
4JJCR 030 001 400	3 X R0.1	3	40	80	6		4JJCR 040 003 500	4 X R0.3	4	50	100	6	
4JJCR 030 001 450	3 X R0.1	3	45	90	6		4JJCR 040 005 130	4 X R0.5	4	13	55	6	
4JJCR 030 002 100	3 X R0.2	3	10	50	6		4JJCR 040 005 160	4 X R0.5	4	16	55	6	
4JJCR 030 002 120	3 X R0.2	3	12	50	6		4JJCR 040 005 200	4 X R0.5	4	20	60	6	
4JJCR 030 002 160	3 X R0.2	3	16	55	6		4JJCR 040 005 250	4 X R0.5	4	25	65	6	
4JJCR 030 002 200	3 X R0.2	3	20	60	6		4JJCR 040 005 300	4 X R0.5	4	30	70	6	
4JJCR 030 002 250	3 X R0.2	3	25	65	6		4JJCR 040 005 350	4 X R0.5	4	35	75	6	
4JJCR 030 002 300	3 X R0.2	3	30	70	6		4JJCR 040 005 400	4 X R0.5	4	40	80	6	
4JJCR 030 002 350	3 X R0.2	3	35	75	6		4JJCR 040 005 450	4 X R0.5	4	45	90	6	
4JJCR 030 002 400	3 X R0.2	3	40	80	6		4JJCR 040 005 500	4 X R0.5	4	50	100	6	
4JJCR 030 002 450	3 X R0.2	3	45	90	6		4JJCR 040 005 550	4 X R0.5	4	55	100	6	
4JJCR 030 003 100	3 X R0.3	3	10	50	6		4JJCR 040 010 130	4 X R1	4	13	55	6	
4JJCR 030 003 120	3 X R0.3	3	12	50	6		4JJCR 040 010 160	4 X R1	4	16	55	6	
4JJCR 030 003 160	3 X R0.3	3	16	55	6		4JJCR 040 010 200	4 X R1	4	20	60	6	
4JJCR 030 003 200	3 X R0.3	3	20	60	6		4JJCR 040 010 250	4 X R1	4	25	65	6	
4JJCR 030 003 250	3 X R0.3	3	25	65	6		4JJCR 040 010 300	4 X R1	4	30	70	6	
4JJCR 030 003 300	3 X R0.3	3	30	70	6		4JJCR 040 010 350	4 X R1	4	35	75	6	
4JJCR 030 003 350	3 X R0.3	3	35	75	6		4JJCR 040 010 400	4 X R1	4	40	80	6	
4JJCR 030 003 400	3 X R0.3	3	40	80	6		4JJCR 040 010 450	4 X R1	4	45	90	6	
4JJCR 030 003 450	3 X R0.3	3	45	90	6		4JJCR 040 010 500	4 X R1	4	50	100	6	
4JJCR 030 005 100	3 X R0.5	3	10	50	6		4JJCR 040 010 550	4 X R1	4	55	100	6	
4JJCR 030 005 120	3 X R0.5	3	12	50	6		4JJCR 050 001 160	5 X R0.1	5	16	60	6	
4JJCR 030 005 160	3 X R0.5	3	16	55	6		4JJCR 050 001 300	5 X R0.1	5	30	70	6	
4JJCR 030 005 200	3 X R0.5	3	20	60	6		4JJCR 050 001 400	5 X R0.1	5	40	80	6	
4JJCR 030 005 250	3 X R0.5	3	25	65	6		4JJCR 050 002 160	5 X R0.2	5	16	60	6	
4JJCR 030 005 300	3 X R0.5	3	30	70	6		4JJCR 050 002 300	5 X R0.2	5	30	70	6	
4JJCR 030 005 350	3 X R0.5	3	35	75	6		4JJCR 050 002 400	5 X R0.2	5	40	80	6	
4JJCR 030 005 400	3 X R0.5	3	40	80	6		4JJCR 050 003 160	5 X R0.3	5	16	60	6	
4JJCR 030 005 450	3 X R0.5	3	45	90	6		4JJCR 050 003 300	5 X R0.3	5	30	70	6	
4JJCR 030 005 500	3 X R0.5	3	50	100	6		4JJCR 050 003 400	5 X R0.3	5	40	80	6	
4JJCR 030 010 100	3 X R1	3	10	50	6		4JJCR 050 005 160	5 X R0.5	5	16	60	6	
4JJCR 030 010 120	3 X R1	3	12	50	6		4JJCR 050 005 300	5 X R0.5	5	30	70	6	
4JJCR 030 010 160	3 X R1	3	16	55	6		4JJCR 050 005 400	5 X R0.5	5	40	80	6	
4JJCR 030 010 200	3 X R1	3	20	60	6		4JJCR 050 005 500	5 X R0.5	5	50	100	6	
4JJCR 030 010 250	3 X R1	3	25	65	6		4JJCR 050 005 600	5 X R0.5	5	60	110	6	
4JJCR 030 010 300	3 X R1	3	30	70	6		4JJCR 050 010 160	5 X R1	5	16	60	6	
4JJCR 030 010 350	3 X R1	3	35	75	6		4JJCR 050 010 300	5 X R1	5	30	70	6	
4JJCR 030 010 400	3 X R1	3	40	80	6		4JJCR 050 010 400	5 X R1	5	40	80	6	
4JJCR 030 010 450	3 X R1	3	45	90	6		4JJCR 050 010 500	5 X R1	5	50	100	6	
4JJCR 030 010 500	3 X R1	3	50	100	6		4JJCR 050 010 600	5 X R1	5	60	110	6	
4JJCR 040 001 130	4 X R0.1	4	13	55	6		4JJCR 060 001 200	6 X R0.1	7	20	60	6	



단위 : mm

Order Number	날경 Diameter D×R	날장 Length of cut L1	유효장 Effective Length L2	전장 Overall Length L	샙크 Shank Dia d	비고	Order Number	날경 Diameter D×R	날장 Length of cut L1	유효장 Effective Length L2	전장 Overall Length L	샙크 Shank Dia d	비고
4JJCR 060 001 400	6 X R0.1	7	40	80	6		4JJCR 120 015 260	12 X R1.5	13	26	80	12	
4JJCR 060 001 500	6 X R0.1	7	50	100	6		4JJCR 120 020 260	12 X R2	13	26	80	12	
4JJCR 060 002 200	6 X R0.2	7	20	60	6		4JJCR 120 020 400	12 X R2	13	40	110	12	
4JJCR 060 002 400	6 X R0.2	7	40	80	6		4JJCR 120 030 260	12 X R3	13	26	80	12	
4JJCR 060 002 500	6 X R0.2	7	50	100	6								
4JJCR 060 003 200	6 X R0.3	7	20	60	6								
4JJCR 060 003 400	6 X R0.3	7	40	80	6								
4JJCR 060 003 500	6 X R0.3	7	50	100	6								
4JJCR 060 005 200	6 X R0.5	7	20	60	6								
4JJCR 060 005 400	6 X R0.5	7	40	80	6								
4JJCR 060 005 500	6 X R0.5	7	50	100	6								
4JJCR 060 005 600	6 X R0.5	7	60	110	6								
4JJCR 060 010 200	6 X R1	7	20	60	6								
4JJCR 060 010 400	6 X R1	7	40	80	6								
4JJCR 060 010 500	6 X R1	7	50	100	6								
4JJCR 060 010 600	6 X R1	7	60	110	6								
4JJCR 060 015 200	6 X R1.5	7	20	60	6								
4JJCR 060 015 400	6 X R1.5	7	40	80	6								
4JJCR 060 015 500	6 X R1.5	7	50	100	6								
4JJCR 060 020 300	6 X R2	7	30	70	6								
4JJCR 060 020 400	6 X R2	7	40	80	6								
4JJCR 060 020 500	6 X R2	7	50	100	6								
4JJCR 080 002 220	8 X R0.2	9	22	65	8								
4JJCR 080 002 400	8 X R0.2	9	40	100	8								
4JJCR 080 003 220	8 X R0.3	9	22	65	8								
4JJCR 080 003 400	8 X R0.3	9	40	100	8								
4JJCR 080 005 220	8 X R0.5	9	22	65	8								
4JJCR 080 005 400	8 X R0.5	9	40	100	8								
4JJCR 080 005 500	8 X R0.5	9	50	120	8								
4JJCR 080 005 600	8 X R0.5	9	60	120	8								
4JJCR 080 010 220	8 X R1	9	22	65	8								
4JJCR 080 010 400	8 X R1	9	40	100	8								
4JJCR 080 010 500	8 X R1	9	50	120	8								
4JJCR 080 010 600	8 X R1	9	60	120	8								
4JJCR 080 015 220	8 X R1.5	9	22	65	8								
4JJCR 080 015 400	8 X R1.5	9	40	100	8								
4JJCR 080 020 220	8 X R2	9	22	65	8								
4JJCR 080 020 400	8 X R2	9	40	100	8								
4JJCR 080 020 500	8 X R2	9	50	120	8								
4JJCR 100 002 240	10 X R0.2	11	24	70	10								
4JJCR 100 002 400	10 X R0.2	11	40	100	10								
4JJCR 100 003 240	10 X R0.3	11	24	70	10								
4JJCR 100 003 400	10 X R0.3	11	40	100	10								
4JJCR 100 005 240	10 X R0.5	11	24	70	10								
4JJCR 100 005 400	10 X R0.5	11	40	100	10								
4JJCR 100 005 500	10 X R0.5	11	50	120	10								
4JJCR 100 005 600	10 X R0.5	11	60	120	10								
4JJCR 100 010 240	10 X R1	11	24	70	10								
4JJCR 100 010 400	10 X R1	11	40	100	10								
4JJCR 100 010 500	10 X R1	11	50	120	10								
4JJCR 100 010 600	10 X R1	11	60	120	10								
4JJCR 100 015 240	10 X R1.5	11	24	70	10								
4JJCR 100 015 400	10 X R1.5	11	40	100	10								
4JJCR 100 020 240	10 X R2	11	24	70	10								
4JJCR 100 020 400	10 X R2	11	40	100	10								
4JJCR 100 020 500	10 X R2	11	50	120	10								
4JJCR 100 025 240	10 X R2.5	11	24	70	10								
4JJCR 120 003 260	12 X R0.3	13	26	80	12								
4JJCR 120 005 260	12 X R0.5	13	26	80	12								
4JJCR 120 005 400	12 X R0.5	13	40	110	12								
4JJCR 120 005 600	12 X R0.5	13	60	130	12								
4JJCR 120 010 260	12 X R1	13	26	80	12								
4JJCR 120 010 400	12 X R1	13	40	110	12								
4JJCR 120 010 600	12 X R1	13	60	130	12								

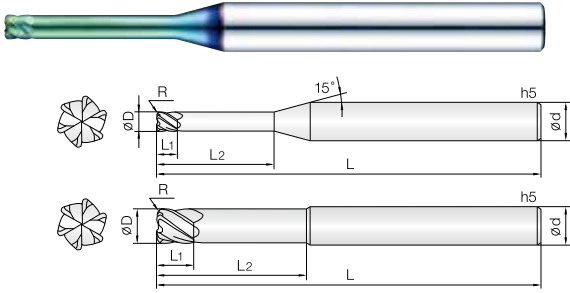

- 고정도강(HRC52~68), 프리하든강 계열의 고정밀 가공 엔드밀
- 고품량 실리콘계 코팅(Si) 처리하여 내마모성이 우수합니다.
- 고정밀 공차 적용으로 초정밀 가공에 적합합니다.
- 코너R 형상을 날부치핑이 적도록 설계하였습니다.
- 다양한 코너R과 유효장으로 맞춤 가공이 가능합니다.
- 초미립자 초경합금(0.2 $\mu$ m)을 채택, 고속절삭시 뛰어난 성능을 발휘합니다.

#### Endmills for pre-hardened and hardened steels(HRC52~68)

- Good wear resistance by high quality Si-based PVD coating.
- High precise edge tolerance.
- Designed for minimizing edge chipping by corner R shape.
- Various corner R and flute length for wide range application.
- Outstanding performance at high speed machining by ultra fine (0.2 $\mu$ m) WC grade.

6

UWC  
초미립자

TISIN-S  
Coating

R  
 $\pm 0.005$

R  
 $\pm 0.01$

38°  
Helix Angle

CUTTING  
DATA

R0.1 ~ 0.5      R1      416P

Condition	D Size	D Tolerance	Condition	D Size	D Tolerance
$\varnothing D \neq \varnothing d$	$\varnothing 3 \sim 12$	+0 ~ -0.01mm	$\varnothing D = \varnothing d$	$\varnothing 6 \sim 12$	-0.005 ~ -0.015mm

단위 : mm

Order Number	날경 Diameter D × R	날장 Length of cut L1	유효장 Effective Length L2	전장 Overall Length L	생크 Shank Dia d	비고	Order Number	날경 Diameter D × R	날장 Length of cut L1	유효장 Effective Length L2	전장 Overall Length L	생크 Shank Dia d	비고
6JJCR 030 001 120	3 X R0.1	3	12	55	6		6JJCR 050 001 160	5 X R0.1	5	16	60	6	
6JJCR 030 001 160	3 X R0.1	3	16	60	6		6JJCR 050 001 200	5 X R0.1	5	20	65	6	
6JJCR 030 001 200	3 X R0.1	3	20	65	6		6JJCR 050 001 300	5 X R0.1	5	30	75	6	
6JJCR 030 001 250	3 X R0.1	3	25	70	6		6JJCR 050 002 160	5 X R0.2	5	16	60	6	
6JJCR 030 001 300	3 X R0.1	3	30	75	6		6JJCR 050 002 200	5 X R0.2	5	20	65	6	
6JJCR 030 002 120	3 X R0.2	3	12	55	6		6JJCR 050 002 300	5 X R0.2	5	30	75	6	
6JJCR 030 002 160	3 X R0.2	3	16	60	6		6JJCR 050 003 160	5 X R0.3	5	16	60	6	
6JJCR 030 002 200	3 X R0.2	3	20	65	6		6JJCR 050 003 200	5 X R0.3	5	20	65	6	
6JJCR 030 002 250	3 X R0.2	3	25	70	6		6JJCR 050 003 300	5 X R0.3	5	30	75	6	
6JJCR 030 002 300	3 X R0.2	3	30	75	6		6JJCR 050 005 160	5 X R0.5	5	16	60	6	
6JJCR 030 003 120	3 X R0.3	3	12	55	6		6JJCR 050 005 200	5 X R0.5	5	20	65	6	
6JJCR 030 003 160	3 X R0.3	3	16	60	6		6JJCR 050 005 300	5 X R0.5	5	30	75	6	
6JJCR 030 003 200	3 X R0.3	3	20	65	6		6JJCR 050 010 160	5 X R1	5	16	60	6	
6JJCR 030 003 250	3 X R0.3	3	25	70	6		6JJCR 050 010 200	5 X R1	5	20	65	6	
6JJCR 030 003 300	3 X R0.3	3	30	75	6		6JJCR 050 010 300	5 X R1	5	30	75	6	
6JJCR 030 005 120	3 X R0.5	3	12	55	6		6JJCR 060 001 210	6 X R0.1	6	21	60	6	
6JJCR 030 005 160	3 X R0.5	3	16	60	6		6JJCR 060 001 310	6 X R0.1	6	31	70	6	
6JJCR 030 005 200	3 X R0.5	3	20	65	6		6JJCR 060 001 410	6 X R0.1	6	41	80	6	
6JJCR 030 005 250	3 X R0.5	3	25	70	6		6JJCR 060 002 210	6 X R0.2	6	21	60	6	
6JJCR 030 005 300	3 X R0.5	3	30	75	6		6JJCR 060 002 310	6 X R0.2	6	31	70	6	
6JJCR 030 010 120	3 X R1	3	12	55	6		6JJCR 060 002 410	6 X R0.2	6	41	80	6	
6JJCR 030 010 160	3 X R1	3	16	60	6		6JJCR 060 003 210	6 X R0.3	6	21	60	6	
6JJCR 030 010 200	3 X R1	3	20	65	6		6JJCR 060 003 310	6 X R0.3	6	31	70	6	
6JJCR 030 010 250	3 X R1	3	25	70	6		6JJCR 060 003 410	6 X R0.3	6	41	80	6	
6JJCR 030 010 300	3 X R1	3	30	75	6		6JJCR 060 005 210	6 X R0.5	6	21	60	6	
6JJCR 040 001 120	4 X R0.1	4	12	55	6		6JJCR 060 005 310	6 X R0.5	6	31	70	6	
6JJCR 040 001 160	4 X R0.1	4	16	60	6		6JJCR 060 005 410	6 X R0.5	6	41	80	6	
6JJCR 040 001 200	4 X R0.1	4	20	65	6		6JJCR 060 010 210	6 X R1	6	21	60	6	
6JJCR 040 001 250	4 X R0.1	4	25	70	6		6JJCR 060 010 310	6 X R1	6	31	70	6	
6JJCR 040 001 300	4 X R0.1	4	30	75	6		6JJCR 060 010 410	6 X R1	6	41	80	6	
6JJCR 040 002 120	4 X R0.2	4	12	55	6		6JJCR 080 003 260	8 X R0.3	8	26	70	8	
6JJCR 040 002 160	4 X R0.2	4	16	60	6		6JJCR 080 003 360	8 X R0.3	8	36	80	8	
6JJCR 040 002 200	4 X R0.2	4	20	65	6		6JJCR 080 003 460	8 X R0.3	8	46	90	8	
6JJCR 040 002 250	4 X R0.2	4	25	70	6		6JJCR 080 005 260	8 X R0.5	8	26	70	8	
6JJCR 040 002 300	4 X R0.2	4	30	75	6		6JJCR 080 005 360	8 X R0.5	8	36	80	8	
6JJCR 040 003 120	4 X R0.3	4	12	55	6		6JJCR 080 005 460	8 X R0.5	8	46	90	8	
6JJCR 040 003 160	4 X R0.3	4	16	60	6		6JJCR 080 010 260	8 X R1	8	26	70	8	
6JJCR 040 003 200	4 X R0.3	4	20	65	6		6JJCR 080 010 360	8 X R1	8	36	80	8	
6JJCR 040 003 250	4 X R0.3	4	25	70	6		6JJCR 080 010 460	8 X R1	8	46	90	8	
6JJCR 040 003 300	4 X R0.3	4	30	75	6		6JJCR 100 003 310	10 X R0.3	10	31	80	10	
6JJCR 040 005 120	4 X R0.5	4	12	55	6		6JJCR 100 003 410	10 X R0.3	10	41	90	10	
6JJCR 040 005 160	4 X R0.5	4	16	60	6		6JJCR 100 003 510	10 X R0.3	10	51	100	10	
6JJCR 040 005 200	4 X R0.5	4	20	65	6		6JJCR 100 005 310	10 X R0.5	10	31	80	10	
6JJCR 040 005 250	4 X R0.5	4	25	70	6		6JJCR 100 005 410	10 X R0.5	10	41	90	10	
6JJCR 040 005 300	4 X R0.5	4	30	75	6		6JJCR 100 005 510	10 X R0.5	10	51	100	10	
6JJCR 040 010 120	4 X R1	4	12	55	6		6JJCR 100 010 310	10 X R1	10	31	80	10	
6JJCR 040 010 160	4 X R1	4	16	60	6		6JJCR 100 010 410	10 X R1	10	41	90	10	
6JJCR 040 010 200	4 X R1	4	20	65	6		6JJCR 100 010 510	10 X R1	10	51	100	10	
6JJCR 040 010 250	4 X R1	4	25	70	6		6JJCR 120 003 360	12 X R0.3	12	36	90	12	
6JJCR 040 010 300	4 X R1	4	30	75	6		6JJCR 120 003 460	12 X R0.3	12	46	100	12	



JJ series

단위: mm

Order Number	날경 Diameter D×R	날장 Length of cut L1	유효장 Effective Length L2	전장 Overall Length L	셴크 Dia d	비고	Order Number	날경 Diameter D×R	날장 Length of cut L1	유효장 Effective Length L2	전장 Overall Length L	셴크 Dia d	비고
6JJCR 120 003 560	12 X R0.3	12	56	110	12								
6JJCR 120 005 360	12 X R0.5	12	36	90	12								
6JJCR 120 005 460	12 X R0.5	12	46	100	12								
6JJCR 120 005 560	12 X R0.5	12	56	110	12								
6JJCR 120 010 360	12 X R1	12	36	90	12								
6JJCR 120 010 460	12 X R1	12	46	100	12								
6JJCR 120 010 560	12 X R1	12	56	110	12								

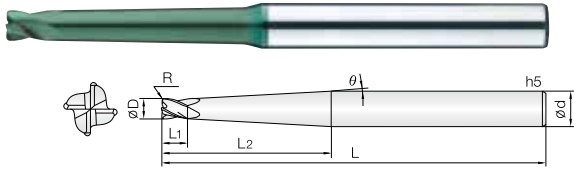

- 고정도강(HRc52~68), 프리하든강 계열의 고정밀 가공 엔드밀
- 고품량 실리콘계 코팅(Si) 처리하여 내마모성이 우수합니다.
- 유효장을 테이퍼 설계하여 깊은 홈 작업시 목부 파손 및 떨림을 최소화 하였습니다.
- 코너R 형상을 날부치핑이 적도록 설계하였습니다.
- 고정밀 공차 적용으로 초정밀 가공에 적합합니다.
- 초미립자 초경합금(0.2 $\mu$ m)을 채택, 고속절삭시 뛰어난 성능을 발휘합니다.

#### • Endmills for pre-hardened and hardened steels(HRc52~68)

- Good wear resistance by high quality Si-based PVD coating.
- Minimize chattering and fracturing by taper designed flute.
- Designed for minimizing edge chipping by corner R shape.
- High precise edge tolerance.
- Outstanding performance at high speed machining by ultra fine (0.2 $\mu$ m) WC grade.



Condition	D Size	D Tolerance
$\varnothing D \neq \varnothing d$	$\varnothing 1 \sim 4$	+0 ~ -0.01mm

Order Number	날경 Diameter D × R	각도 Angle $\theta$	날장 Length of cut L1	유효장 Effective Length L2	전장 Overall Length L	샤프크 Shank Dia d	비고	Order Number	날경 Diameter D × R	각도 Angle $\theta$	날장 Length of cut L1	유효장 Effective Length L2	전장 Overall Length L	샤프크 Shank Dia d	비고
4JJTC 010 001 0601	1 X R0.1	1°	1	6	50	4		4JJTC 020 005 4001	2 X R0.5	1°	2	40	80	4	
4JJTC 010 001 1001	1 X R0.1	1°	1	10	50	4		4JJTC 020 005 5001	2 X R0.5	1°	2	50	90	4	
4JJTC 010 001 1501	1 X R0.1	1°	1	15	50	4		4JJTC 030 002 2001	3 X R0.2	1°	3	20	60	6	
4JJTC 010 001 2001	1 X R0.1	1°	1	20	60	4		4JJTC 030 002 3001	3 X R0.2	1°	3	30	70	6	
4JJTC 010 001 2501	1 X R0.1	1°	1	25	60	4		4JJTC 030 002 4001	3 X R0.2	1°	3	40	80	6	
4JJTC 010 001 3001	1 X R0.1	1°	1	30	70	4		4JJTC 030 002 5001	3 X R0.2	1°	3	50	90	6	
4JJTC 010 001 3501	1 X R0.1	1°	1	35	75	4		4JJTC 030 002 6001	3 X R0.2	1°	3	60	100	6	
4JJTC 010 002 0601	1 X R0.2	1°	1	6	50	4		4JJTC 030 003 4001	3 X R0.3	1°	3	40	80	6	
4JJTC 010 002 1001	1 X R0.2	1°	1	10	50	4		4JJTC 030 003 5001	3 X R0.3	1°	3	50	90	6	
4JJTC 010 002 1501	1 X R0.2	1°	1	15	50	4		4JJTC 030 003 6001	3 X R0.3	1°	3	60	100	6	
4JJTC 010 002 2001	1 X R0.2	1°	1	20	60	4		4JJTC 030 005 2001	3 X R0.5	1°	3	20	60	6	
4JJTC 010 002 2501	1 X R0.2	1°	1	25	60	4		4JJTC 030 005 3001	3 X R0.5	1°	3	30	70	6	
4JJTC 010 002 3001	1 X R0.2	1°	1	30	70	4		4JJTC 030 005 4001	3 X R0.5	1°	3	40	80	6	
4JJTC 010 002 3501	1 X R0.2	1°	1	35	75	4		4JJTC 030 005 5001	3 X R0.5	1°	3	50	90	6	
4JJTC 010 003 1001	1 X R0.3	1°	1	10	50	4		4JJTC 030 005 6001	3 X R0.5	1°	3	60	100	6	
4JJTC 010 003 1501	1 X R0.3	1°	1	15	50	4		4JJTC 040 002 2001	4 X R0.2	1°	4	20	60	6	
4JJTC 010 003 2001	1 X R0.3	1°	1	20	60	4		4JJTC 040 002 3001	4 X R0.2	1°	4	30	70	6	
4JJTC 010 003 2501	1 X R0.3	1°	1	25	60	4		4JJTC 040 002 4001	4 X R0.2	1°	4	40	80	6	
4JJTC 015 002 1001	1.5 X R0.2	1°	1.5	10	50	4		4JJTC 040 002 5001	4 X R0.2	1°	4	50	90	6	
4JJTC 015 002 1501	1.5 X R0.2	1°	1.5	15	50	4		4JJTC 040 002 6001	4 X R0.2	1°	4	60	100	6	
4JJTC 015 002 2001	1.5 X R0.2	1°	1.5	20	60	4		4JJTC 040 003 4001	4 X R0.3	1°	4	40	80	6	
4JJTC 015 002 2501	1.5 X R0.2	1°	1.5	25	60	4		4JJTC 040 003 5001	4 X R0.3	1°	4	50	90	6	
4JJTC 015 002 3001	1.5 X R0.2	1°	1.5	30	70	4		4JJTC 040 003 6001	4 X R0.3	1°	4	60	100	6	
4JJTC 015 002 3501	1.5 X R0.2	1°	1.5	35	75	4		4JJTC 040 005 2001	4 X R0.5	1°	4	20	60	6	
4JJTC 015 003 1501	1.5 X R0.3	1°	1.5	15	50	4		4JJTC 040 005 3001	4 X R0.5	1°	4	30	70	6	
4JJTC 015 003 2001	1.5 X R0.3	1°	1.5	20	60	4		4JJTC 040 005 4001	4 X R0.5	1°	4	40	80	6	
4JJTC 015 003 2501	1.5 X R0.3	1°	1.5	25	60	4		4JJTC 040 005 5001	4 X R0.5	1°	4	50	90	6	
4JJTC 015 005 1001	1.5 X R0.5	1°	1.5	10	50	4		4JJTC 040 005 6001	4 X R0.5	1°	4	60	100	6	
4JJTC 015 005 1501	1.5 X R0.5	1°	1.5	15	50	4									
4JJTC 015 005 2001	1.5 X R0.5	1°	1.5	20	60	4									
4JJTC 015 005 2501	1.5 X R0.5	1°	1.5	25	60	4									
4JJTC 015 005 3001	1.5 X R0.5	1°	1.5	30	70	4									
4JJTC 015 005 3501	1.5 X R0.5	1°	1.5	35	75	4									
4JJTC 020 002 1201	2 X R0.2	1°	2	12	50	4									
4JJTC 020 002 1601	2 X R0.2	1°	2	16	50	4									
4JJTC 020 002 2001	2 X R0.2	1°	2	20	60	4									
4JJTC 020 002 2501	2 X R0.2	1°	2	25	60	4									
4JJTC 020 002 3001	2 X R0.2	1°	2	30	70	4									
4JJTC 020 002 3501	2 X R0.2	1°	2	35	75	4									
4JJTC 020 002 4001	2 X R0.2	1°	2	40	80	4									
4JJTC 020 002 5001	2 X R0.2	1°	2	50	90	4									
4JJTC 020 003 2001	2 X R0.3	1°	2	20	60	4									
4JJTC 020 003 3001	2 X R0.3	1°	2	30	70	4									
4JJTC 020 003 4001	2 X R0.3	1°	2	40	80	4									
4JJTC 020 005 1201	2 X R0.5	1°	2	12	50	4									
4JJTC 020 005 1601	2 X R0.5	1°	2	16	50	4									
4JJTC 020 005 2001	2 X R0.5	1°	2	20	60	4									
4JJTC 020 005 2501	2 X R0.5	1°	2	25	60	4									
4JJTC 020 005 3001	2 X R0.5	1°	2	30	70	4									
4JJTC 020 005 3501	2 X R0.5	1°	2	35	75	4									

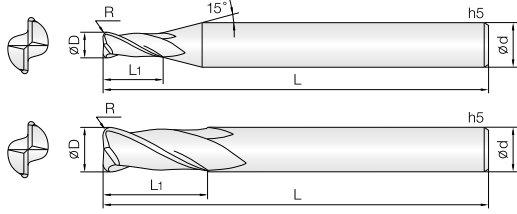

- 고경도강(HRC52~68), 프리하든강 계열의 고정밀 가공 엔드밀
- 고품질 실리콘계 코팅(Si) 처리하여 내마모성이 우수합니다.
- 고정밀 공차 적용으로 초정밀 가공에 적합합니다.
- 코너R 형상을 날부치핑이 적도록 설계하였습니다.
- 다양한 코너R과 전장으로 맞춤 가공이 가능합니다.
- 초미립자 초경합금(0.2 $\mu$ m)을 채택, 고속절삭시 뛰어난 성능을 발휘합니다.

#### Endmills for pre-hardened and hardened steels(HRC52~68)

- Good wear resistance by high quality Si-based PVD coating.
- High precise edge tolerance.
- Designed for minimizing edge chipping by corner R shape.
- Various corner R and overall length for wide range application.
- Outstanding performance at high speed machining by ultra fine (0.2 $\mu$ m) WC grade.

2

UWC  
초미립자

TISIN-S  
Coating

R  
±0.005

R  
±0.01

R  
±0.015

30°  
Helix Angle

CUTTING  
DATA

R0.02 ~ 0.5    R1 ~ 1.5    R2 ~ 5    417P

Condition	D Size	D Tolerance	Condition	D Size	D Tolerance
ØD ≠ Ød	Ø0.2 ~ 14	+0 ~ -0.01mm	ØD = Ød	Ø4 ~ 12	-0.005 ~ -0.015mm
				Ø14	-0.01 ~ -0.02mm

단위 : mm

Order Number	날경 Diameter D × R	날장 Length of cut L1	전장 Overall Length L	샙크 Shank Dia d	비고	Order Number	날경 Diameter D × R	날장 Length of cut L1	전장 Overall Length L	샙크 Shank Dia d	비고
2JJC 002 0002 S04	0.2 X R0.02	0.4	45	4		2JJC 030 001 S06	3 X R0.1	8	60	6	
2JJC 002 0005 S04	0.2 X R0.05	0.4	45	4		2JJC 030 002 S06	3 X R0.2	8	60	6	
2JJC 003 0002 S04	0.3 X R0.02	0.6	45	4		2JJC 030 003 S06	3 X R0.3	8	60	6	
2JJC 003 0005 S04	0.3 X R0.05	0.6	45	4		2JJC 030 005 S06	3 X R0.5	8	60	6	
2JJC 003 001 S04	0.3 X R0.1	0.6	45	4		2JJC 030 010 S06	3 X R1	8	60	6	
2JJC 004 0002 S04	0.4 X R0.02	0.8	45	4		2JJC 040 001 S04	4 X R0.1	9	60	4	
2JJC 004 0005 S04	0.4 X R0.05	0.8	45	4		2JJC 040 001 S06	4 X R0.1	10	70	6	
2JJC 004 001 S04	0.4 X R0.1	0.8	45	4		2JJC 040 002 S04	4 X R0.2	9	60	4	
2JJC 005 0002 S04	0.5 X R0.02	1	45	4		2JJC 040 002 S06	4 X R0.2	10	70	6	
2JJC 005 0005 S04	0.5 X R0.05	1	45	4		2JJC 040 003 S04	4 X R0.3	9	60	4	
2JJC 005 001 S04	0.5 X R0.1	1	45	4		2JJC 040 003 S06	4 X R0.3	10	70	6	
2JJC 006 0002 S04	0.6 X R0.02	1.2	45	4		2JJC 040 005 S04	4 X R0.5	9	60	4	
2JJC 006 0005 S04	0.6 X R0.05	1.2	45	4		2JJC 040 005 S06	4 X R0.5	10	70	6	
2JJC 006 001 S04	0.6 X R0.1	1.2	45	4		2JJC 040 010 S04	4 X R1	9	60	4	
2JJC 006 002 S04	0.6 X R0.2	1.2	45	4		2JJC 040 010 S06	4 X R1	10	70	6	
2JJC 007 0005 S04	0.7 X R0.05	1.4	45	4		2JJC 050 001 S06	5 X R0.1	13	75	6	
2JJC 007 001 S04	0.7 X R0.1	1.4	45	4		2JJC 050 002 S06	5 X R0.2	13	75	6	
2JJC 007 002 S04	0.7 X R0.2	1.4	45	4		2JJC 050 003 S06	5 X R0.3	13	75	6	
2JJC 008 0002 S04	0.8 X R0.02	1.6	45	4		2JJC 050 005 S06	5 X R0.5	13	75	6	
2JJC 008 0005 S04	0.8 X R0.05	1.6	45	4		2JJC 050 010 S06	5 X R1	13	75	6	
2JJC 008 001 S04	0.8 X R0.1	1.6	45	4		2JJC 060 001 060	6 X R0.1	11	60	6	
2JJC 008 002 S04	0.8 X R0.2	1.6	45	4		2JJC 060 001 090	6 X R0.1	13	90	6	
2JJC 009 0005 S04	0.9 X R0.05	1.8	45	4		2JJC 060 002 060	6 X R0.2	11	60	6	
2JJC 009 001 S04	0.9 X R0.1	1.8	45	4		2JJC 060 002 090	6 X R0.2	13	90	6	
2JJC 010 0002 S04	1 X R0.02	2.5	45	4		2JJC 060 003 060	6 X R0.3	11	60	6	
2JJC 010 0005 S04	1 X R0.05	2.5	45	4		2JJC 060 003 090	6 X R0.3	13	90	6	
2JJC 010 001 S04	1 X R0.1	2.5	45	4		2JJC 060 005 060	6 X R0.5	11	60	6	
2JJC 010 002 S04	1 X R0.2	2.5	45	4		2JJC 060 005 090	6 X R0.5	13	90	6	
2JJC 010 003 S04	1 X R0.3	2.5	45	4		2JJC 060 005 110	6 X R0.5	13	110	6	
2JJC 012 0002 S04	1.2 X R0.02	3.2	45	4		2JJC 060 010 060	6 X R1	11	60	6	
2JJC 012 0005 S04	1.2 X R0.05	3.2	45	4		2JJC 060 010 090	6 X R1	13	90	6	
2JJC 012 001 S04	1.2 X R0.1	3.2	45	4		2JJC 060 010 110	6 X R1	13	110	6	
2JJC 012 002 S04	1.2 X R0.2	3.2	45	4		2JJC 060 015 060	6 X R1.5	11	60	6	
2JJC 012 003 S04	1.2 X R0.3	3.2	45	4		2JJC 060 015 090	6 X R1.5	13	90	6	
2JJC 015 0002 S04	1.5 X R0.02	4	45	4		2JJC 060 020 060	6 X R2	11	60	6	
2JJC 015 0005 S04	1.5 X R0.05	4	45	4		2JJC 060 020 090	6 X R2	13	90	6	
2JJC 015 001 S04	1.5 X R0.1	4	45	4		2JJC 060 025 090	6 X R2.5	13	90	6	
2JJC 015 002 S04	1.5 X R0.2	4	45	4		2JJC 080 001 070	8 X R0.1	16	70	8	
2JJC 015 003 S04	1.5 X R0.3	4	45	4		2JJC 080 001 100	8 X R0.1	19	100	8	
2JJC 015 005 S04	1.5 X R0.5	4	45	4		2JJC 080 002 070	8 X R0.2	16	70	8	
2JJC 020 0002 S04	2 X R0.02	6	45	4		2JJC 080 002 100	8 X R0.2	19	100	8	
2JJC 020 0005 S04	2 X R0.05	6	45	4		2JJC 080 003 070	8 X R0.3	16	70	8	
2JJC 020 001 S04	2 X R0.1	6	45	4		2JJC 080 003 100	8 X R0.3	19	100	8	
2JJC 020 002 S04	2 X R0.2	6	45	4		2JJC 080 005 070	8 X R0.5	16	70	8	
2JJC 020 003 S04	2 X R0.3	6	45	4		2JJC 080 005 100	8 X R0.5	19	100	8	
2JJC 020 005 S04	2 X R0.5	6	45	4		2JJC 080 005 120	8 X R0.5	19	120	8	
2JJC 025 001 S04	2.5 X R0.1	6	50	4		2JJC 080 010 070	8 X R1	16	70	8	
2JJC 025 002 S04	2.5 X R0.2	6	50	4		2JJC 080 010 100	8 X R1	19	100	8	
2JJC 025 003 S04	2.5 X R0.3	6	50	4		2JJC 080 010 120	8 X R1	19	120	8	
2JJC 025 005 S04	2.5 X R0.5	6	50	4		2JJC 080 015 070	8 X R1.5	16	70	8	



단위 : mm

Order Number	날경 Diameter D × R	날장 Length of cut L1	전장 Overall Length L	생크 Shank Dia d	비고	Order Number	날경 Diameter D × R	날장 Length of cut L1	전장 Overall Length L	생크 Shank Dia d	비고
2JJC 080 015 100	8 X R1.5	19	100	8							
2JJC 080 020 070	8 X R2	16	70	8							
2JJC 080 020 100	8 X R2	19	100	8							
2JJC 080 025 100	8 X R2.5	19	100	8							
2JJC 080 030 100	8 X R3	19	100	8							
2JJC 080 035 100	8 X R3.5	19	100	8							
2JJC 100 001 075	10 X R0.1	19	75	10							
2JJC 100 001 100	10 X R0.1	22	100	10							
2JJC 100 002 075	10 X R0.2	19	75	10							
2JJC 100 002 100	10 X R0.2	22	100	10							
2JJC 100 003 075	10 X R0.3	19	75	10							
2JJC 100 003 100	10 X R0.3	22	100	10							
2JJC 100 005 075	10 X R0.5	19	75	10							
2JJC 100 005 100	10 X R0.5	22	100	10							
2JJC 100 005 120	10 X R0.5	22	120	10							
2JJC 100 010 075	10 X R1	19	75	10							
2JJC 100 010 100	10 X R1	22	100	10							
2JJC 100 010 120	10 X R1	22	120	10							
2JJC 100 015 075	10 X R1.5	19	75	10							
2JJC 100 015 100	10 X R1.5	22	100	10							
2JJC 100 020 075	10 X R2	19	75	10							
2JJC 100 020 100	10 X R2	22	100	10							
2JJC 100 025 100	10 X R2.5	22	100	10							
2JJC 100 030 100	10 X R3	22	100	10							
2JJC 100 040 100	10 X R4	22	100	10							
2JJC 120 001 080	12 X R0.1	22	80	12							
2JJC 120 001 110	12 X R0.1	26	110	12							
2JJC 120 002 080	12 X R0.2	22	80	12							
2JJC 120 002 110	12 X R0.2	26	110	12							
2JJC 120 003 080	12 X R0.3	22	80	12							
2JJC 120 003 110	12 X R0.3	26	110	12							
2JJC 120 005 080	12 X R0.5	22	80	12							
2JJC 120 005 110	12 X R0.5	26	110	12							
2JJC 120 005 130	12 X R0.5	26	130	12							
2JJC 120 010 080	12 X R1	22	80	12							
2JJC 120 010 110	12 X R1	26	110	12							
2JJC 120 010 130	12 X R1	26	130	12							
2JJC 120 015 080	12 X R1.5	22	80	12							
2JJC 120 015 110	12 X R1.5	26	110	12							
2JJC 120 020 080	12 X R2	22	80	12							
2JJC 120 020 110	12 X R2	26	110	12							
2JJC 120 020 130	12 X R2	26	130	12							
2JJC 120 025 110	12 X R2.5	26	110	12							
2JJC 120 030 110	12 X R3	26	110	12							
2JJC 120 040 110	12 X R4	26	110	12							
2JJC 120 050 110	12 X R5	26	110	12							
2JJC 140 005 110	14 X R0.5	30	110	14							
2JJC 140 010 110	14 X R1	30	110	14							
2JJC 140 020 110	14 X R2	30	110	14							

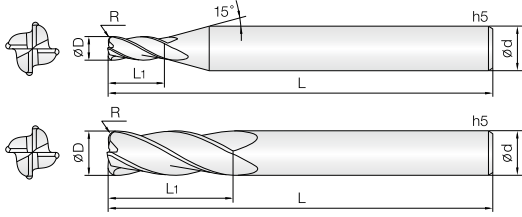

- 고경도강(HRc52~68), 프리하든강 계열의 고정밀 가공 엔드밀
- 고품질 실리콘계 코팅(Si) 처리하여 내마모성이 우수합니다.
- 고정밀 공차 적용으로 초정밀 가공에 적합합니다.
- 코너R 형상을 날부치핑이 적도록 설계하였습니다.
- 다양한 코너R과 전장으로 맞춤 가공이 가능합니다.
- 초미립자 초경합금(0.2µm)을 채택, 고속절삭시 뛰어난 성능을 발휘합니다.

#### Endmills for pre-hardened and hardened steels(HRc52~68)

- Good wear resistance by high quality Si-based PVD coating.
- High precise edge tolerance.
- Designed for minimizing edge chipping by corner R shape.
- Various corner R and overall length for wide range application.
- Outstanding performance at high speed machining by ultra fine (0.2µm) WC grade.

4

UWC  
초미립자

TISIN-S  
Coating

R  
±0.005

R  
±0.01

R  
±0.015

30°  
Helix Angle

CUTTING  
DATA

R0.05 ~ 0.5   R1 ~ 1.5   R2 ~ 3   418P

Condition	D Size	D Tolerance	Condition	D Size	D Tolerance
ØD ≠ Ød	Ø0.4 ~ 16	+0 ~ -0.01mm	ØD = Ød	Ø3 ~ 12	-0.005 ~ -0.015mm
				Ø14 ~ 16	-0.01 ~ -0.02mm

단위 : mm

Order Number	날경 Diameter D × R	날장 Length of cut L1	전장 Overall Length L	샙크 Shank Dia d	비고	Order Number	날경 Diameter D × R	날장 Length of cut L1	전장 Overall Length L	샙크 Shank Dia d	비고
New 4JJC 004 0005 S04	0.4 X R0.05	0.8	45	4		4JJC 040 001 S06	4 X R0.1	10	70	6	
4JJC 005 0005 S04	0.5 X R0.05	1	45	4		4JJC 040 002 S04	4 X R0.2	9	60	4	
4JJC 005 001 S04	0.5 X R0.1	1	45	4		4JJC 040 002 S06	4 X R0.2	10	70	6	
4JJC 006 0005 S04	0.6 X R0.05	1.2	45	4		4JJC 040 003 S04	4 X R0.3	9	60	4	
4JJC 006 001 S04	0.6 X R0.1	1.2	45	4		4JJC 040 003 S06	4 X R0.3	10	70	6	
4JJC 007 0005 S04	0.7 X R0.05	1.4	45	4		4JJC 040 005 S04	4 X R0.5	9	60	4	
4JJC 007 001 S04	0.7 X R0.1	1.4	45	4		4JJC 040 005 S06	4 X R0.5	10	70	6	
4JJC 008 0005 S04	0.8 X R0.05	1.6	45	4		4JJC 040 010 S04	4 X R1	9	60	4	
4JJC 008 001 S04	0.8 X R0.1	1.6	45	4		4JJC 040 010 S06	4 X R1	10	70	6	
4JJC 009 0005 S04	0.9 X R0.05	1.8	45	4		4JJC 045 002 S06	4.5 X R0.2	11	75	6	
4JJC 009 001 S04	0.9 X R0.1	1.8	45	4		4JJC 045 003 S06	4.5 X R0.3	11	75	6	
4JJC 010 0005 S04	1 X R0.05	2.5	45	4		4JJC 045 005 S06	4.5 X R0.5	11	75	6	
4JJC 010 001 S04	1 X R0.1	2.5	45	4		4JJC 045 010 S06	4.5 X R1	11	75	6	
4JJC 010 002 S04	1 X R0.2	2.5	45	4		4JJC 050 001 S06	5 X R0.1	13	75	6	
4JJC 010 003 S04	1 X R0.3	2.5	45	4		4JJC 050 002 S06	5 X R0.2	13	75	6	
4JJC 015 0005 S04	1.5 X R0.05	4	45	4		4JJC 050 003 S06	5 X R0.3	13	75	6	
4JJC 015 001 S04	1.5 X R0.1	4	45	4		4JJC 050 005 S06	5 X R0.5	13	75	6	
4JJC 015 002 S04	1.5 X R0.2	4	45	4		4JJC 050 010 S06	5 X R1	13	75	6	
4JJC 015 003 S04	1.5 X R0.3	4	45	4		4JJC 060 0005 055	6 X R0.05	11	55	6	
4JJC 015 005 S04	1.5 X R0.5	4	45	4		4JJC 060 0005 080	6 X R0.05	13	80	6	
4JJC 020 0005 S04	2 X R0.05	6	45	4		4JJC 060 001 055	6 X R0.1	11	55	6	
4JJC 020 001 S04	2 X R0.1	6	45	4		4JJC 060 001 080	6 X R0.1	13	80	6	
4JJC 020 002 S04	2 X R0.2	6	45	4		4JJC 060 002 055	6 X R0.2	11	55	6	
4JJC 020 003 S04	2 X R0.3	6	45	4		4JJC 060 002 080	6 X R0.2	13	80	6	
4JJC 020 005 S04	2 X R0.5	6	45	4		4JJC 060 002 100	6 X R0.2	13	100	6	
4JJC 025 001 S04	2.5 X R0.1	6	50	4		4JJC 060 002 120	6 X R0.2	13	120	6	
4JJC 025 002 S04	2.5 X R0.2	6	50	4		4JJC 060 003 055	6 X R0.3	11	55	6	
4JJC 025 003 S04	2.5 X R0.3	6	50	4		4JJC 060 003 080	6 X R0.3	13	80	6	
4JJC 025 005 S04	2.5 X R0.5	6	50	4		4JJC 060 003 100	6 X R0.3	13	100	6	
4JJC 030 001 S03	3 X R0.1	8	60	3		4JJC 060 003 120	6 X R0.3	13	120	6	
New 4JJC 030 001 S04	3 X R0.1	8	60	4		4JJC 060 005 055	6 X R0.5	11	55	6	
4JJC 030 001 S06	3 X R0.1	8	60	6		4JJC 060 005 080	6 X R0.5	13	80	6	
4JJC 030 002 S03	3 X R0.2	8	60	3		4JJC 060 005 100	6 X R0.5	13	100	6	
New 4JJC 030 002 S04	3 X R0.2	8	60	4		4JJC 060 005 120	6 X R0.5	13	120	6	
4JJC 030 002 S06	3 X R0.2	8	60	6		4JJC 060 010 055	6 X R1	11	55	6	
4JJC 030 003 S03	3 X R0.3	8	60	3		4JJC 060 010 080	6 X R1	13	80	6	
New 4JJC 030 003 S04	3 X R0.3	8	60	4		4JJC 060 010 100	6 X R1	13	100	6	
4JJC 030 003 S06	3 X R0.3	8	60	6		4JJC 060 010 120	6 X R1	13	120	6	
4JJC 030 005 S03	3 X R0.5	8	60	3		4JJC 060 015 055	6 X R1.5	11	55	6	
New 4JJC 030 005 S04	3 X R0.5	8	60	4		4JJC 060 015 080	6 X R1.5	13	80	6	
4JJC 030 005 S06	3 X R0.5	8	60	6		4JJC 060 020 055	6 X R2	11	55	6	
4JJC 030 010 S03	3 X R1	8	60	3		4JJC 060 020 080	6 X R2	13	80	6	
New 4JJC 030 010 S04	3 X R1	8	60	4		4JJC 070 002 S08	7 X R0.2	16	80	8	
4JJC 030 010 S06	3 X R1	8	60	6		4JJC 070 003 S08	7 X R0.3	16	80	8	
4JJC 035 001 S06	3.5 X R0.1	9	70	6		4JJC 070 005 S08	7 X R0.5	16	80	8	
4JJC 035 002 S06	3.5 X R0.2	9	70	6		4JJC 070 010 S08	7 X R1	16	80	8	
4JJC 035 003 S06	3.5 X R0.3	9	70	6		4JJC 080 001 060	8 X R0.1	16	60	8	
4JJC 035 005 S06	3.5 X R0.5	9	70	6		4JJC 080 001 090	8 X R0.1	19	90	8	
4JJC 035 010 S06	3.5 X R1	9	70	6		4JJC 080 002 060	8 X R0.2	16	60	8	
4JJC 040 001 S04	4 X R0.1	9	60	4		4JJC 080 002 090	8 X R0.2	19	90	8	



단위 : mm

Order Number	날경 Diameter D×R	날장 Length of cut L1	전장 Overall Length L	샙크 Dia d	비고	Order Number	날경 Diameter D×R	날장 Length of cut L1	전장 Overall Length L	샙크 Dia d	비고
4JJC 080 003 060	8 X R0.3	16	60	8		4JJC 120 005 110	12 X R0.5	26	110	12	
4JJC 080 003 090	8 X R0.3	19	90	8		4JJC 120 005 130	12 X R0.5	26	130	12	
4JJC 080 005 060	8 X R0.5	16	60	8		4JJC 120 005 160	12 X R0.5	26	160	12	
4JJC 080 005 090	8 X R0.5	19	90	8		4JJC 120 010 075	12 X R1	22	75	12	
4JJC 080 005 110	8 X R0.5	19	110	8		4JJC 120 010 110	12 X R1	26	110	12	
4JJC 080 005 150	8 X R0.5	19	150	8		4JJC 120 010 130	12 X R1	26	130	12	
4JJC 080 010 060	8 X R1	16	60	8		4JJC 120 010 160	12 X R1	26	160	12	
4JJC 080 010 090	8 X R1	19	90	8		4JJC 120 015 075	12 X R1.5	22	75	12	
4JJC 080 010 110	8 X R1	19	110	8		4JJC 120 015 110	12 X R1.5	26	110	12	
4JJC 080 010 150	8 X R1	19	150	8		4JJC 120 020 075	12 X R2	22	75	12	
4JJC 080 015 060	8 X R1.5	16	60	8		4JJC 120 020 110	12 X R2	26	110	12	
4JJC 080 015 090	8 X R1.5	19	90	8		4JJC 120 020 130	12 X R2	26	130	12	
4JJC 080 020 060	8 X R2	16	60	8		4JJC 120 020 160	12 X R2	26	160	12	
4JJC 080 020 090	8 X R2	19	90	8		4JJC 120 025 075	12 X R2.5	22	75	12	
4JJC 090 002 S10	9 X R0.2	20	90	10		4JJC 120 025 110	12 X R2.5	26	110	12	
4JJC 090 003 S10	9 X R0.3	20	90	10		4JJC 120 030 075	12 X R3	22	75	12	
4JJC 090 005 S10	9 X R0.5	20	90	10		4JJC 120 030 110	12 X R3	26	110	12	
4JJC 090 010 S10	9 X R1	20	90	10		4JJC 140 005 110	14 X R0.5	30	110	14	
4JJC 100 001 070	10 X R0.1	19	70	10		4JJC 140 010 110	14 X R1	30	110	14	
4JJC 100 001 100	10 X R0.1	22	100	10		4JJC 140 020 110	14 X R2	30	110	14	
4JJC 100 002 070	10 X R0.2	19	70	10		4JJC 160 005 110	16 X R0.5	32	110	16	
4JJC 100 002 100	10 X R0.2	22	100	10		4JJC 160 005 160	16 X R0.5	32	160	16	
4JJC 100 003 070	10 X R0.3	19	70	10		4JJC 160 010 110	16 X R1	32	110	16	
4JJC 100 003 100	10 X R0.3	22	100	10		4JJC 160 010 160	16 X R1	32	160	16	
4JJC 100 005 070	10 X R0.5	19	70	10							
4JJC 100 005 100	10 X R0.5	22	100	10							
4JJC 100 005 120	10 X R0.5	22	120	10							
4JJC 100 005 150	10 X R0.5	22	150	10							
4JJC 100 010 070	10 X R1	19	70	10							
4JJC 100 010 100	10 X R1	22	100	10							
4JJC 100 010 120	10 X R1	22	120	10							
4JJC 100 010 150	10 X R1	22	150	10							
4JJC 100 015 070	10 X R1.5	19	70	10							
4JJC 100 015 100	10 X R1.5	22	100	10							
4JJC 100 020 070	10 X R2	19	70	10							
4JJC 100 020 100	10 X R2	22	100	10							
4JJC 100 020 120	10 X R2	22	120	10							
4JJC 100 020 150	10 X R2	22	150	10							
4JJC 100 025 070	10 X R2.5	19	70	10							
4JJC 100 025 100	10 X R2.5	22	100	10							
4JJC 110 003 S12	11 X R0.3	24	100	12							
4JJC 110 005 S12	11 X R0.5	24	100	12							
4JJC 110 010 S12	11 X R1	24	100	12							
4JJC 120 001 075	12 X R0.1	22	75	12							
4JJC 120 001 110	12 X R0.1	26	110	12							
4JJC 120 002 075	12 X R0.2	22	75	12							
4JJC 120 002 110	12 X R0.2	26	110	12							
4JJC 120 003 075	12 X R0.3	22	75	12							
4JJC 120 003 110	12 X R0.3	26	110	12							
4JJC 120 005 075	12 X R0.5	22	75	12							



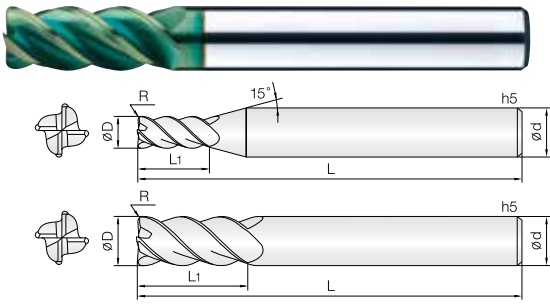

- 고정도강(HRC52~68), 프리하든강 계열의 고정밀 가공 엔드밀
- 고품질 실리콘계 코팅(Si) 처리하여 내마모성이 우수합니다.
- 고정밀 공차 적용으로 초정밀 가공에 적합합니다.
- 코너R 형상을 날부치핑이 적도록 설계하였습니다.
- 45° 헬릭스 형상으로 설계하여 고속, 고이송 가공에 적합합니다.
- 초미립자 초경합금(0.2µm)을 채택, 고속절삭시 뛰어난 성능을 발휘합니다.

#### Endmills for pre-hardened and hardened steels(HRC52~68)

- Good wear resistance by high quality Si-based PVD coating.
- High precise edge tolerance.
- Designed for minimizing edge chipping by corner R shape.
- 45° degree helix design for high speed, feed condition.
- Outstanding performance at high speed machining by ultra fine (0.2µm) WC grade.

4

UWC  
초미립자

TISIN-S  
Coating

R  
± 0.005

R  
± 0.01

R  
± 0.015

45°  
Helix Angle

CUTTING  
DATA

R0.05 ~ 0.5   R1 ~ 1.5   R2 ~ 5   419P

Condition	D Size	D Tolerance	Condition	D Size	D Tolerance
ØD ≠ Ød	Ø1 ~ 20	+0 ~ -0.01mm	ØD = Ød	Ø6 ~ 12	-0.005 ~ -0.015mm
				Ø14 ~ 20	-0.01 ~ -0.02mm

단위 : mm

Order Number	날경 Diameter D × R	날장 Length of cut L1	전장 Overall Length L	샙크 Shank Dia d	비고	Order Number	날경 Diameter D × R	날장 Length of cut L1	전장 Overall Length L	샙크 Shank Dia d	비고
4JJCR 010 0005 050	1 X R0.05	2	50	6		4JJCR 080 002 070	8 X R0.2	16	70	8	
4JJCR 010 001 050	1 X R0.1	2	50	6		4JJCR 080 002 090	8 X R0.2	19	90	8	
4JJCR 010 002 050	1 X R0.2	2	50	6		4JJCR 080 003 070	8 X R0.3	16	70	8	
4JJCR 010 003 050	1 X R0.3	2	50	6		4JJCR 080 003 090	8 X R0.3	19	90	8	
4JJCR 012 0005 050	1.2 X R0.05	2.5	50	6		4JJCR 080 005 070	8 X R0.5	16	70	8	
4JJCR 012 001 050	1.2 X R0.1	2.5	50	6		4JJCR 080 005 090	8 X R0.5	19	90	8	
4JJCR 012 002 050	1.2 X R0.2	2.5	50	6		4JJCR 080 010 070	8 X R1	16	70	8	
4JJCR 012 003 050	1.2 X R0.3	2.5	50	6		4JJCR 080 010 090	8 X R1	19	90	8	
4JJCR 015 0005 050	1.5 X R0.05	3	50	6		4JJCR 080 015 070	8 X R1.5	16	70	8	
4JJCR 015 001 050	1.5 X R0.1	3	50	6		4JJCR 080 015 090	8 X R1.5	19	90	8	
4JJCR 015 002 050	1.5 X R0.2	3	50	6		4JJCR 080 020 070	8 X R2	16	70	8	
4JJCR 015 003 050	1.5 X R0.3	3	50	6		4JJCR 080 020 090	8 X R2	19	90	8	
4JJCR 015 005 050	1.5 X R0.5	3	50	6		4JJCR 100 002 075	10 X R0.2	20	75	10	
4JJCR 020 001 050	2 X R0.1	5	50	6		4JJCR 100 002 100	10 X R0.2	23	100	10	
4JJCR 020 002 050	2 X R0.2	5	50	6		4JJCR 100 003 075	10 X R0.3	20	75	10	
4JJCR 020 003 050	2 X R0.3	5	50	6		4JJCR 100 003 100	10 X R0.3	23	100	10	
4JJCR 020 005 050	2 X R0.5	5	50	6		4JJCR 100 005 075	10 X R0.5	20	75	10	
4JJCR 025 001 060	2.5 X R0.1	6	60	6		4JJCR 100 005 100	10 X R0.5	23	100	10	
4JJCR 025 002 060	2.5 X R0.2	6	60	6		4JJCR 100 010 075	10 X R1	20	75	10	
4JJCR 025 003 060	2.5 X R0.3	6	60	6		4JJCR 100 010 100	10 X R1	23	100	10	
4JJCR 025 005 060	2.5 X R0.5	6	60	6		4JJCR 100 015 075	10 X R1.5	20	75	10	
4JJCR 030 001 070	3 X R0.1	6	70	6		4JJCR 100 015 100	10 X R1.5	23	100	10	
4JJCR 030 002 070	3 X R0.2	6	70	6		4JJCR 100 020 075	10 X R2	20	75	10	
4JJCR 030 003 070	3 X R0.3	6	70	6		4JJCR 100 020 100	10 X R2	23	100	10	
4JJCR 030 005 070	3 X R0.5	6	70	6		4JJCR 120 003 080	12 X R0.3	23	80	12	
4JJCR 030 010 070	3 X R1	6	70	6		4JJCR 120 003 110	12 X R0.3	27	110	12	
4JJCR 040 001 070	4 X R0.1	8	70	6		4JJCR 120 005 080	12 X R0.5	23	80	12	
4JJCR 040 002 070	4 X R0.2	8	70	6		4JJCR 120 005 110	12 X R0.5	27	110	12	
4JJCR 040 003 070	4 X R0.3	8	70	6		4JJCR 120 010 080	12 X R1	23	80	12	
4JJCR 040 005 070	4 X R0.5	8	70	6		4JJCR 120 010 110	12 X R1	27	110	12	
4JJCR 040 010 070	4 X R1	8	70	6		4JJCR 120 015 080	12 X R1.5	23	80	12	
4JJCR 050 001 080	5 X R0.1	10	80	6		4JJCR 120 015 110	12 X R1.5	27	110	12	
4JJCR 050 002 080	5 X R0.2	10	80	6		4JJCR 120 020 080	12 X R2	23	80	12	
4JJCR 050 003 080	5 X R0.3	10	80	6		4JJCR 120 020 110	12 X R2	27	110	12	
4JJCR 050 005 080	5 X R0.5	10	80	6		4JJCR 120 030 080	12 X R3	23	80	12	
4JJCR 050 010 080	5 X R1	10	80	6		4JJCR 120 030 110	12 X R3	27	110	12	
4JJCR 060 001 060	6 X R0.1	12	60	6		4JJCR 140 005 110	14 X R0.5	30	110	14	
4JJCR 060 001 080	6 X R0.1	15	80	6		4JJCR 140 010 110	14 X R1	30	110	14	
4JJCR 060 002 060	6 X R0.2	12	60	6		4JJCR 140 020 110	14 X R2	30	110	14	
4JJCR 060 002 080	6 X R0.2	15	80	6		4JJCR 160 005 120	16 X R0.5	32	120	16	
4JJCR 060 003 060	6 X R0.3	12	60	6		4JJCR 160 010 120	16 X R1	32	120	16	
4JJCR 060 003 080	6 X R0.3	15	80	6		4JJCR 160 020 120	16 X R2	32	120	16	
4JJCR 060 005 060	6 X R0.5	12	60	6		4JJCR 160 030 120	16 X R3	32	120	16	
4JJCR 060 005 080	6 X R0.5	15	80	6		4JJCR 200 005 130	20 X R0.5	38	130	20	
4JJCR 060 010 060	6 X R1	12	60	6		4JJCR 200 010 130	20 X R1	38	130	20	
4JJCR 060 010 080	6 X R1	15	80	6		4JJCR 200 020 130	20 X R2	38	130	20	
4JJCR 060 015 060	6 X R1.5	12	60	6		4JJCR 200 030 130	20 X R3	38	130	20	
4JJCR 060 015 080	6 X R1.5	15	80	6		4JJCR 200 040 130	20 X R4	38	130	20	
4JJCR 060 020 060	6 X R2	12	60	6		4JJCR 200 050 130	20 X R5	38	130	20	
4JJCR 060 020 080	6 X R2	15	80	6							

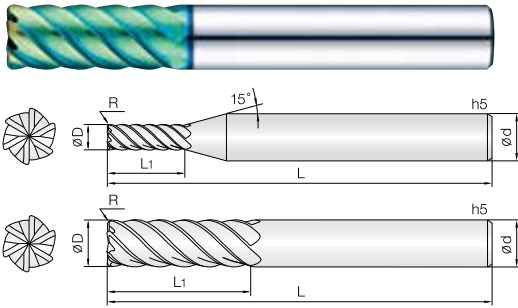

- 고정도강(HRc52~68), 프리하든강 계열의 고정밀 가공 엔드밀
- 고품량 실리콘계 코팅(Si) 처리하여 내마모성이 우수합니다.
- 45° 헬릭스 형상으로 설계하여 고속, 고이송 가공에 적합합니다.
- 측벽 가공, 코너부, 무구배면 가공시 가공물의 표면조도가 뛰어나며, 인선날 길이 증가로 내마모성이 더욱 좋아집니다.
- 초미립자 초경합금(0.2 $\mu$ m)을 채택, 고속절삭시 뛰어난 성능을 발휘합니다.

#### • Endmills for pre-hardened and hardened steels(HRc52~68)

- Good wear resistance by high quality Si-based PVD coating.
- 45° degree helix design for high speed, feed condition.
- Excellent surface roughness for side, corner, shoulder milling and improved wear resistance due to increased edge length.
- Outstanding performance at high speed machining by ultra fine (0.2 $\mu$ m) WC grade.

6

UWC  
초미립자

TISIN-S  
Coating

R

R

R

45°  
Helix Angle

CUTTING  
DATA

R0.1 ~ 0.5
R1 ~ 1.5
R2
419P

Condition	D Size	D Tolerance	Condition	D Size	D Tolerance
$\varnothing D \neq \varnothing d$	$\varnothing 3 \sim 16$	+0 ~ -0.01mm	$\varnothing D = \varnothing d$	$\varnothing 6 \sim 12$	-0.005 ~ -0.015mm
				$\varnothing 16$	-0.01 ~ -0.02mm

단위 : mm

Order Number	날경 Diameter D × R	날장 Length of cut L1	전장 Overall Length L	생크 Shank Dia d	비고	Order Number	날경 Diameter D × R	날장 Length of cut L1	전장 Overall Length L	생크 Shank Dia d	비고
6JJCR 030 001 060	3 X R0.1	7.5	60	6							
6JJCR 030 002 060	3 X R0.2	7.5	60	6							
6JJCR 030 003 060	3 X R0.3	7.5	60	6							
6JJCR 030 005 060	3 X R0.5	7.5	60	6							
6JJCR 030 010 060	3 X R1	7.5	60	6							
6JJCR 040 001 060	4 X R0.1	10	60	6							
6JJCR 040 002 060	4 X R0.2	10	60	6							
6JJCR 040 003 060	4 X R0.3	10	60	6							
6JJCR 040 005 060	4 X R0.5	10	60	6							
6JJCR 040 010 060	4 X R1	10	60	6							
6JJCR 050 002 060	5 X R0.2	13	60	6							
6JJCR 050 003 060	5 X R0.3	13	60	6							
6JJCR 050 005 060	5 X R0.5	13	60	6							
6JJCR 050 010 060	5 X R1	13	60	6							
6JJCR 060 001 060	6 X R0.1	15	60	6							
6JJCR 060 002 060	6 X R0.2	15	60	6							
6JJCR 060 002 080	6 X R0.2	15	80	6							
6JJCR 060 003 060	6 X R0.3	15	60	6							
6JJCR 060 003 080	6 X R0.3	15	80	6							
6JJCR 060 005 060	6 X R0.5	15	60	6							
6JJCR 060 005 080	6 X R0.5	15	80	6							
6JJCR 060 010 060	6 X R1	15	60	6							
6JJCR 060 010 080	6 X R1	15	80	6							
6JJCR 080 002 070	8 X R0.2	20	70	8							
6JJCR 080 003 070	8 X R0.3	20	70	8							
6JJCR 080 003 090	8 X R0.3	20	90	8							
6JJCR 080 005 070	8 X R0.5	20	70	8							
6JJCR 080 005 090	8 X R0.5	20	90	8							
6JJCR 080 010 070	8 X R1	20	70	8							
6JJCR 080 010 090	8 X R1	20	90	8							
6JJCR 080 015 070	8 X R1.5	20	70	8							
6JJCR 100 002 075	10 X R0.2	25	75	10							
6JJCR 100 003 075	10 X R0.3	25	75	10							
6JJCR 100 003 100	10 X R0.3	25	100	10							
6JJCR 100 005 075	10 X R0.5	25	75	10							
6JJCR 100 005 100	10 X R0.5	25	100	10							
6JJCR 100 010 075	10 X R1	25	75	10							
6JJCR 100 010 100	10 X R1	25	100	10							
6JJCR 100 020 075	10 X R2	25	75	10							
6JJCR 120 002 080	12 X R0.2	30	80	12							
6JJCR 120 003 080	12 X R0.3	30	80	12							
6JJCR 120 003 110	12 X R0.3	30	110	12							
6JJCR 120 005 080	12 X R0.5	30	80	12							
6JJCR 120 005 110	12 X R0.5	30	110	12							
6JJCR 120 010 080	12 X R1	30	80	12							
6JJCR 120 010 110	12 X R1	30	110	12							
6JJCR 120 020 080	12 X R2	30	80	12							
6JJCR 160 005 110	16 X R0.5	50	110	16							
6JJCR 160 010 110	16 X R1	50	110	16							
6JJCR 160 020 110	16 X R2	50	110	16							

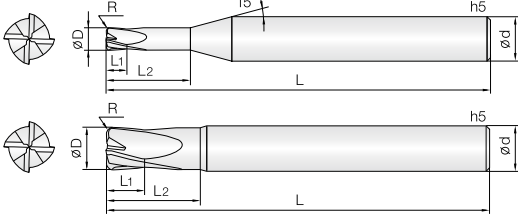

- 고경도강(HRc52~68), 프리하든강 계열의 고정밀 가공 엔드밀
- 고품량 실리콘계 코팅(Si) 처리하여 내마모성이 우수합니다.
- 저속 RPM에서 고이송 작업이 가능하도록 설계하였습니다..
- 종삭 및 황삭 가공시 작업 효율이 극대화 됩니다.
- 항절력이 높은 초미립자 초경합금을 채택하여, 고이송 작업시 엔드밀의 파손을 최소화 하였습니다.

#### • Endmills for pre-hardened and hardened steels(HRc52~68)

- Good wear resistance by high quality Si-based PVD coating.
- High precise edge tolerance.
- Designed for low speed with high feed condition.
- Suitable for heavy duty and roughing application.
- Minimize fracturing at high feed by high TRS ultra fine WC grade.

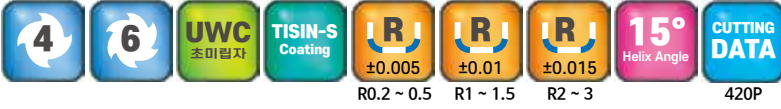

Condition	D Size	D Tolerance
øD ≠ ød	ø1 ~ 16	+0 ~ -0.01mm

Condition	D Size	D Tolerance
øD = ød	ø6 ~ 12	-0.005 ~ -0.015mm
	ø16	-0.01 ~ -0.02mm

단위 : mm

Order Number	날경 D × R	날장 Length of cut L1	유효장 Effective Length L2	전장 Overall Length L	샤프크 Shank Dia d	비고
4JJRC 010 002 025	1 X R0.2	1	2.5	50	4	
4JJRC 015 005 040	1.5 X R0.5	1.5	4	50	4	
4JJRC 020 005 060	2 X R0.5	2	6	50	6	
4JJRC 030 005 080	3 X R0.5	3	8	50	6	
4JJRC 040 005 120	4 X R0.5	4	12	60	6	
4JJRC 040 005 160	4 X R0.5	4	16	60	6	
4JJRC 040 010 120	4 X R1	4	12	60	6	
4JJRC 040 010 160	4 X R1	4	16	60	6	
4JJRC 050 005 150	5 X R0.5	5	15	60	6	
4JJRC 050 010 150	5 X R1	5	15	60	6	
4JJRC 060 003 150	6 X R0.3	6	15	60	6	
4JJRC 060 005 150	6 X R0.5	6	15	60	6	
4JJRC 060 010 150	6 X R1	6	15	60	6	
4JJRC 060 015 150	6 X R1.5	6	15	60	6	
4JJRC 080 003 160	8 X R0.3	8	16	60	8	
4JJRC 080 005 160	8 X R0.5	8	16	60	8	
4JJRC 080 005 200	8 X R0.5	8	20	80	8	
4JJRC 080 005 300	8 X R0.5	8	30	110	8	
4JJRC 080 010 160	8 X R1	8	16	60	8	
4JJRC 080 010 200	8 X R1	8	20	80	8	
4JJRC 080 010 300	8 X R1	8	30	110	8	
4JJRC 080 020 160	8 X R2	8	16	60	8	
4JJRC 080 020 200	8 X R2	8	20	80	8	
4JJRC 080 020 300	8 X R2	8	30	110	8	
4JJRC 100 003 200	10 X R0.3	10	20	70	10	
4JJRC 100 005 200	10 X R0.5	10	20	70	10	
4JJRC 100 005 250	10 X R0.5	10	25	90	10	
4JJRC 100 005 300	10 X R0.5	10	30	120	10	
4JJRC 100 010 200	10 X R1	10	20	70	10	
4JJRC 100 010 250	10 X R1	10	25	90	10	
4JJRC 100 010 300	10 X R1	10	30	120	10	
4JJRC 100 020 200	10 X R2	10	20	70	10	
4JJRC 100 020 250	10 X R2	10	25	90	10	
4JJRC 100 020 300	10 X R2	10	30	120	10	
4JJRC 120 005 250	12 X R0.5	12	25	80	12	
4JJRC 120 005 300	12 X R0.5	12	30	100	12	
4JJRC 120 005 350	12 X R0.5	12	35	130	12	
4JJRC 120 010 250	12 X R1	12	25	80	12	
4JJRC 120 010 300	12 X R1	12	30	100	12	
4JJRC 120 010 350	12 X R1	12	35	130	12	
4JJRC 120 020 250	12 X R2	12	25	80	12	
4JJRC 120 020 300	12 X R2	12	30	100	12	
4JJRC 120 020 350	12 X R2	12	35	130	12	
4JJRC 120 030 250	12 X R3	12	25	80	12	
4JJRC 160 010 300	16 X R1	16	30	110	16	
4JJRC 160 010 400	16 X R1	16	40	160	16	
4JJRC 160 020 300	16 X R2	16	30	110	16	
4JJRC 160 020 400	16 X R2	16	40	160	16	

Order Number	날경 D × R	날장 Length of cut L1	전장 Overall Length L	샤프크 Shank Dia d	비고
6JJRC 060 005 060	6 X R0.5	12	60	6	
6JJRC 060 010 060	6 X R1	12	60	6	
6JJRC 080 005 060	8 X R0.5	16	60	8	
6JJRC 080 010 060	8 X R1	16	60	8	
6JJRC 080 020 060	8 X R2	16	60	8	
6JJRC 100 005 070	10 X R0.5	20	70	10	
6JJRC 100 010 070	10 X R1	20	70	10	
6JJRC 100 020 070	10 X R2	20	70	10	
6JJRC 120 005 080	12 X R0.5	25	80	12	
6JJRC 120 010 080	12 X R1	25	80	12	
6JJRC 120 020 080	12 X R2	25	80	12	
6JJRC 160 005 100	16 X R0.5	30	100	16	
6JJRC 160 005 160	16 X R0.5	30	160	16	
6JJRC 160 010 100	16 X R1	30	100	16	
6JJRC 160 010 160	16 X R1	30	160	16	

# 4&6JJDRC 4&6 Flutes JJ Double Corner Radius Cutters for Hardened Steels

## 4&6날 고정도재 가공용 제이제이 더블 코너 레디우스 커터

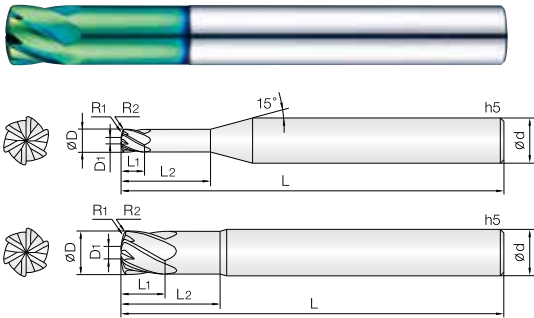

- 고경도강(HRc52~68), 프리하든강 계열의 고정밀 가공 엔드밀
- 고함량 실리콘계 코팅(Si) 처리하여 내마모성이 우수합니다.
- 저속 RPM에서 고이송 작업이 가능하도록 설계하였습니다.
- 중삭 및 황삭 가공시 작업 효율이 극대화 됩니다.
- 바닥 인선부의 형상에 복합R 설계를 적용하여 절삭칩이 작게 배출되며, 절삭 부하를 줄였습니다.

### Endmills for pre-hardened and hardened steels(HRc52~68)

- Good wear resistance by high quality Si-based PVD coating.
- Designed for low speed with high feed condition.
- Suitable for heavy duty and roughing application.
- Applied multi-radius design on the endface of the tool, reduced cutting stress by splitting small chip emission.

**4**

**6**

**WC**  
미립자

**TISIN-S**  
Coating

**R**  
±0.015

**30°**  
Helix Angle

**CUTTING**  
DATA

Condition	D Size	D Tolerance	Condition	D Size	D Tolerance
ØD ≠ Ød	Ø1 ~ 16	+0 ~ -0.01mm	ØD = Ød	Ø6 ~ 12	-0.005 ~ -0.015mm
				Ø16	-0.01 ~ -0.02mm

419P

단위 : mm

Order Number	날경 Diameter D	바닥R Large Radius R1	코너R Corner Radius R2	선단경 Front Diameter D1	날장 Length of cut L1	유효장 Effective Length L2	전장 Overall Length L	생크 Dia d	비고
4JJDRC 010 010 030	1	1	0.1	0.28	1	3	50	4	
4JJDRC 020 020 060	2	2	0.1	0.56	2	6	50	6	
4JJDRC 030 030 090	3	3	0.2	0.68	3	9	60	6	
4JJDRC 040 040 120	4	4	0.2	0.8	4	12	60	6	
4JJDRC 050 050 150	5	5	0.3	1.08	5	15	60	6	
6JJDRC 060 060 180	6	6	0.3	1.22	6	18	60	6	
6JJDRC 080 080 240	8	8	0.5	1.76	8	24	75	8	
6JJDRC 100 100 300	10	10	0.5	2.02	10	30	80	10	
6JJDRC 120 120 360	12	12	0.5	2.28	12	36	100	12	
6JJDRC 160 160 450	16	16	0.8	2.8	16	45	110	16	

