

- 동 및 동합금, 알루미늄 합금, 비철합금 가공용 엔드밀
- JCRO 코팅 처리하여 다양한 피삭재 가공시 인선부에 스트레스가 적으며, 피삭재의 면조도가 향상됩니다.
- 45° 헬릭스 형상과 깊은 포켓으로 설계하여 칩배출이 우수하며, 고속, 고이송 가공에 적합합니다.
- 항절력이 높은 미립자 초경합금(0.5µm)을 채택, 엔드밀의 파손을 최소화.

Endmills for copper, copper alloys, non-ferrous and non-metallic materials

- JCRO coating provides wear resistance improvement as well as avoid edge stress in various applications.
- Minimize fracturing by high TRS fine(0.5µm) WC grade.
- High speed, feed applicable by 45° degree helix and deep chip pocket design

2

WC
미립자

JCRO
Coating

R
±0.005

R
±0.01

R
±0.015

45°
Helix Angle

CUTTING
DATA

Condition	D Size	D Tolerance
ØD ≠ Ød	Ø0.5 ~ 16	+0 ~ -0.01mm

Condition	D Size	D Tolerance
ØD = Ød	Ø6 ~ 12	-0.005 ~ -0.015mm
	Ø16	-0.01 ~ -0.02mm

단위 : mm

Order Number	날경 Diameter R × D	날장 Length of cut L1	유효장 Effective Length L2	전장 Overall Length L	샙크 Shank Dia d	비고	Order Number	날경 Diameter R × D	날장 Length of cut L1	유효장 Effective Length L2	전장 Overall Length L	샙크 Shank Dia d	비고
2COB 005 010 S04	0.25R X 0.5	0.7	1	45	4		2COB 025 200 S06	1.25R X 2.5	4	6	50	6	
2COB 005 020 S04	0.25R X 0.5	0.7	2	45	4		2COB 030 080 S06	1.5R X 3	4.5	8	60	6	
2COB 005 030 S04	0.25R X 0.5	0.7	3	45	4		2COB 030 120 S06	1.5R X 3	4.5	12	60	6	
2COB 005 040 S04	0.25R X 0.5	0.7	4	45	4		2COB 030 160 S06	1.5R X 3	4.5	16	60	6	
2COB 005 050 S04	0.25R X 0.5	0.7	5	45	4		2COB 030 200 S06	1.5R X 3	4.5	20	60	6	
2COB 005 060 S04	0.25R X 0.5	0.7	6	45	4		2COB 030 250 S06	1.5R X 3	4.5	25	70	6	
2COB 006 020 S04	0.3R X 0.6	0.9	2	45	4		2COB 030 300 S06	1.5R X 3	4.5	30	70	6	
2COB 006 030 S04	0.3R X 0.6	0.9	3	45	4		2COB 030 400 S06	1.5R X 3	4.5	40	80	6	
2COB 006 040 S04	0.3R X 0.6	0.9	4	45	4		2COB 040 100 S06	2R X 4	6	10	60	6	
2COB 006 050 S04	0.3R X 0.6	0.9	5	45	4		2COB 040 160 S06	2R X 4	6	16	60	6	
2COB 006 060 S04	0.3R X 0.6	0.9	6	45	4		2COB 040 200 S06	2R X 4	6	20	60	6	
2COB 006 080 S04	0.3R X 0.6	0.9	8	45	4		2COB 040 250 S06	2R X 4	6	25	70	6	
2COB 006 100 S04	0.3R X 0.6	0.9	10	45	4		2COB 040 300 S06	2R X 4	6	30	70	6	
2COB 008 020 S04	0.4R X 0.8	1.2	2	45	4		2COB 040 400 S06	2R X 4	6	40	80	6	
2COB 008 030 S04	0.4R X 0.8	1.2	3	45	4		2COB 050 160 S06	2.5R X 5	8	16	80	6	
2COB 008 040 S04	0.4R X 0.8	1.2	4	45	4		2COB 050 200 S06	2.5R X 5	8	20	80	6	
2COB 008 060 S04	0.4R X 0.8	1.2	6	45	4		2COB 050 250 S06	2.5R X 5	8	25	80	6	
2COB 008 080 S04	0.4R X 0.8	1.2	8	45	4		2COB 060 150 S06	3R X 6	9	15	90	6	
2COB 008 100 S04	0.4R X 0.8	1.2	10	45	4		2COB 060 300 S06	3R X 6	9	30	90	6	
2COB 008 120 S04	0.4R X 0.8	1.2	12	45	4		2COB 060 400 S06	3R X 6	9	40	90	6	
2COB 010 030 S04	0.5R X 1	1.5	3	50	4		2COB 080 200 S08	4R X 8	12	20	100	8	
2COB 010 050 S04	0.5R X 1	1.5	5	50	4		2COB 100 250 S10	5R X 10	15	25	100	10	
2COB 010 080 S04	0.5R X 1	1.5	8	50	4		2COB 120 300 S12	6R X 12	18	30	110	12	
2COB 010 100 S04	0.5R X 1	1.5	10	50	4		2COB 160 600 S16	8R X 16	30	60	160	16	
2COB 010 120 S04	0.5R X 1	1.5	12	50	4								
2COB 010 160 S04	0.5R X 1	1.5	16	50	4								
2COB 010 200 S04	0.5R X 1	1.5	20	50	4								
2COB 012 030 S04	0.6R X 1.2	1.8	3	50	4								
2COB 012 040 S04	0.6R X 1.2	1.8	4	50	4								
2COB 012 060 S04	0.6R X 1.2	1.8	6	50	4								
2COB 012 080 S04	0.6R X 1.2	1.8	8	50	4								
2COB 012 100 S04	0.6R X 1.2	1.8	10	50	4								
2COB 012 120 S04	0.6R X 1.2	1.8	12	50	4								
2COB 015 050 S04	0.75R X 1.5	2	5	50	4								
2COB 015 080 S04	0.75R X 1.5	2	8	50	4								
2COB 015 100 S04	0.75R X 1.5	2	10	50	4								
2COB 015 120 S04	0.75R X 1.5	2	12	50	4								
2COB 015 160 S04	0.75R X 1.5	2	16	50	4								
2COB 015 200 S04	0.75R X 1.5	2	20	50	4								
2COB 020 050 S06	1R X 2	3	5	50	6								
2COB 020 080 S06	1R X 2	3	8	50	6								
2COB 020 100 S06	1R X 2	3	10	50	6								
2COB 020 120 S06	1R X 2	3	12	60	6								
2COB 020 160 S06	1R X 2	3	16	60	6								
2COB 020 200 S06	1R X 2	3	20	60	6								
2COB 020 250 S06	1R X 2	3	25	65	6								
2COB 025 060 S06	1.25R X 2.5	4	6	50	6								
2COB 025 100 S06	1.25R X 2.5	4	10	50	6								
2COB 025 120 S06	1.25R X 2.5	4	12	60	6								
2COB 025 160 S06	1.25R X 2.5	4	16	60	6								

FOR COPPER

2날 동가공용 리브 코너 레디우스 엔드밀

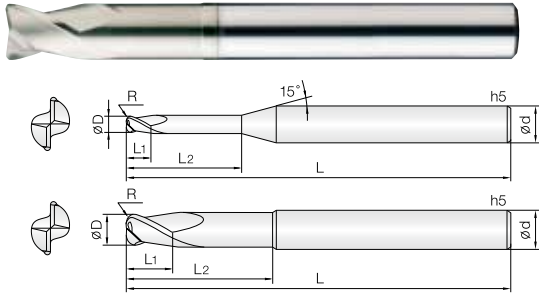

- 동 및 동합금, 알루미늄 합금, 비철합금 가공용 엔드밀
- JCRO 코팅 처리하여 다양한 피삭재 가공시 인선부에 스트레스가 적으며, 피삭재의 면조도가 향상됩니다.
- 깊은 포켓으로 설계하여 칩배출이 원활합니다.
- 항절력이 높은 미립자 초경합금 (0.5 μ m)을 채택, 엔드밀의 파손을 최소화 하였습니다.
- Endmills for copper, copper alloys, non-ferrous and non-metallic materials
- JCRO coating provides wear resistance improvement as well as avoid edge stress in various applications.
- Smooth chip outflow by deep chip pocket.
- Minimize fracturing by high TRS fine(0.5 μ m) WC grade.

2

WC
미립자

JCRO
Coating

R
 ± 0.005

R
 ± 0.01

30°
Helix Angle

CUTTING
DATA

R0.1 ~ 0.5 R1 ~ 1.5 481P

Condition	D Size	D Tolerance	Condition	D Size	D Tolerance
$\phi D \neq \phi d$	$\phi 1 \sim 12$	+0 ~ -0.01mm	$\phi D = \phi d$	$\phi 6 \sim 12$	-0.005 ~ -0.015mm

단위 : mm

Order Number	날경 Diameter D × R	날장 Length of cut L1	유효장 Effective Length L2	전장 Overall Length L	샙크 Shank Dia d	비고	Order Number	날경 Diameter D × R	날장 Length of cut L1	유효장 Effective Length L2	전장 Overall Length L	샙크 Shank Dia d	비고
2COR 010 001 040	1 X R0.1	1.5	4	50	4		2COR 020 001 250	2 X R0.1	3	25	60	4	
2COR 010 001 060	1 X R0.1	1.5	6	50	4		2COR 020 002 060	2 X R0.2	3	6	50	4	
2COR 010 001 080	1 X R0.1	1.5	8	50	4		2COR 020 002 100	2 X R0.2	3	10	50	4	
2COR 010 001 100	1 X R0.1	1.5	10	50	4		2COR 020 002 120	2 X R0.2	3	12	50	4	
2COR 010 001 120	1 X R0.1	1.5	12	50	4		2COR 020 002 160	2 X R0.2	3	16	50	4	
2COR 010 001 160	1 X R0.1	1.5	16	50	4		2COR 020 002 200	2 X R0.2	3	20	50	4	
2COR 010 001 200	1 X R0.1	1.5	20	50	4		2COR 020 002 250	2 X R0.2	3	25	60	4	
2COR 010 002 040	1 X R0.2	1.5	4	50	4		2COR 020 003 060	2 X R0.3	3	6	50	4	
2COR 010 002 060	1 X R0.2	1.5	6	50	4		2COR 020 003 100	2 X R0.3	3	10	50	4	
2COR 010 002 080	1 X R0.2	1.5	8	50	4		2COR 020 003 120	2 X R0.3	3	12	50	4	
2COR 010 002 100	1 X R0.2	1.5	10	50	4		2COR 020 003 160	2 X R0.3	3	16	50	4	
2COR 010 002 120	1 X R0.2	1.5	12	50	4		2COR 020 003 200	2 X R0.3	3	20	50	4	
2COR 010 002 160	1 X R0.2	1.5	16	50	4		2COR 020 003 250	2 X R0.3	3	25	60	4	
2COR 010 002 200	1 X R0.2	1.5	20	50	4		2COR 020 005 060	2 X R0.5	3	6	50	4	
2COR 010 003 040	1 X R0.3	1.5	4	50	4		2COR 020 005 100	2 X R0.5	3	10	50	4	
2COR 010 003 060	1 X R0.3	1.5	6	50	4		2COR 020 005 120	2 X R0.5	3	12	50	4	
2COR 010 003 080	1 X R0.3	1.5	8	50	4		2COR 020 005 140	2 X R0.5	3	14	50	4	
2COR 010 003 100	1 X R0.3	1.5	10	50	4		2COR 020 005 160	2 X R0.5	3	16	50	4	
2COR 010 003 120	1 X R0.3	1.5	12	50	4		2COR 020 005 200	2 X R0.5	3	20	50	4	
2COR 010 003 160	1 X R0.3	1.5	16	50	4		2COR 020 005 250	2 X R0.5	3	25	60	4	
2COR 010 003 200	1 X R0.3	1.5	20	50	4		2COR 025 001 060	2.5 X R0.1	3.5	6	50	4	
2COR 015 001 060	1.5 X R0.1	2	6	50	4		2COR 025 001 100	2.5 X R0.1	3.5	10	50	4	
2COR 015 001 100	1.5 X R0.1	2	10	50	4		2COR 025 001 120	2.5 X R0.1	3.5	12	50	4	
2COR 015 001 120	1.5 X R0.1	2	12	50	4		2COR 025 001 160	2.5 X R0.1	3.5	16	50	4	
2COR 015 001 160	1.5 X R0.1	2	16	50	4		2COR 025 001 200	2.5 X R0.1	3.5	20	50	4	
2COR 015 001 200	1.5 X R0.1	2	20	50	4		2COR 025 001 250	2.5 X R0.1	3.5	25	60	4	
2COR 015 001 250	1.5 X R0.1	2	25	60	4		2COR 025 002 060	2.5 X R0.2	3.5	6	50	4	
2COR 015 002 060	1.5 X R0.2	2	6	50	4		2COR 025 002 100	2.5 X R0.2	3.5	10	50	4	
2COR 015 002 100	1.5 X R0.2	2	10	50	4		2COR 025 002 120	2.5 X R0.2	3.5	12	50	4	
2COR 015 002 120	1.5 X R0.2	2	12	50	4		2COR 025 002 160	2.5 X R0.2	3.5	16	50	4	
2COR 015 002 160	1.5 X R0.2	2	16	50	4		2COR 025 002 200	2.5 X R0.2	3.5	20	50	4	
2COR 015 002 200	1.5 X R0.2	2	20	50	4		2COR 025 002 250	2.5 X R0.2	3.5	25	60	4	
2COR 015 002 250	1.5 X R0.2	2	25	60	4		2COR 025 003 060	2.5 X R0.3	3.5	6	50	4	
2COR 015 003 060	1.5 X R0.3	2	6	50	4		2COR 025 003 100	2.5 X R0.3	3.5	10	50	4	
2COR 015 003 100	1.5 X R0.3	2	10	50	4		2COR 025 003 120	2.5 X R0.3	3.5	12	50	4	
2COR 015 003 120	1.5 X R0.3	2	12	50	4		2COR 025 003 160	2.5 X R0.3	3.5	16	50	4	
2COR 015 003 160	1.5 X R0.3	2	16	50	4		2COR 025 003 200	2.5 X R0.3	3.5	20	50	4	
2COR 015 003 200	1.5 X R0.3	2	20	50	4		2COR 025 003 250	2.5 X R0.3	3.5	25	60	4	
2COR 015 003 250	1.5 X R0.3	2	25	60	4		2COR 025 005 060	2.5 X R0.5	3.5	6	50	4	
2COR 015 005 060	1.5 X R0.5	2	6	50	4		2COR 025 005 100	2.5 X R0.5	3.5	10	50	4	
2COR 015 005 100	1.5 X R0.5	2	10	50	4		2COR 025 005 120	2.5 X R0.5	3.5	12	50	4	
2COR 015 005 120	1.5 X R0.5	2	12	50	4		2COR 025 005 160	2.5 X R0.5	3.5	16	50	4	
2COR 015 005 160	1.5 X R0.5	2	16	50	4		2COR 025 005 200	2.5 X R0.5	3.5	20	50	4	
2COR 015 005 200	1.5 X R0.5	2	20	50	4		2COR 025 005 250	2.5 X R0.5	3.5	25	60	4	
2COR 015 005 250	1.5 X R0.5	2	25	60	4		2COR 030 001 100	3 X R0.1	4	10	55	6	
2COR 020 001 060	2 X R0.1	3	6	50	4		2COR 030 001 120	3 X R0.1	4	12	55	6	
2COR 020 001 100	2 X R0.1	3	10	50	4		2COR 030 001 160	3 X R0.1	4	16	55	6	
2COR 020 001 120	2 X R0.1	3	12	50	4		2COR 030 001 200	3 X R0.1	4	20	60	6	
2COR 020 001 160	2 X R0.1	3	16	50	4		2COR 030 001 250	3 X R0.1	4	25	65	6	
2COR 020 001 200	2 X R0.1	3	20	50	4		2COR 030 001 300	3 X R0.1	4	30	70	6	

FOR COPPER



단위 : mm

Order Number	날경 Diameter D×R	날장 Length of cut L1	유효장 Effective Length L2	전장 Overall Length L	샙크 Shank Dia d	비고	Order Number	날경 Diameter D×R	날장 Length of cut L1	유효장 Effective Length L2	전장 Overall Length L	샙크 Shank Dia d	비고
2COR 030 001 350	3 X R0.1	4	35	75	6		2COR 040 005 160	4 X R0.5	5	16	55	6	
2COR 030 001 400	3 X R0.1	4	40	80	6		2COR 040 005 200	4 X R0.5	5	20	60	6	
2COR 030 002 100	3 X R0.2	4	10	55	6		2COR 040 005 300	4 X R0.5	5	30	70	6	
2COR 030 002 120	3 X R0.2	4	12	55	6		2COR 040 005 400	4 X R0.5	5	40	80	6	
2COR 030 002 160	3 X R0.2	4	16	55	6		2COR 040 010 120	4 X R1	5	12	55	6	
2COR 030 002 200	3 X R0.2	4	20	60	6		2COR 040 010 160	4 X R1	5	16	55	6	
2COR 030 002 250	3 X R0.2	4	25	65	6		2COR 040 010 200	4 X R1	5	20	60	6	
2COR 030 002 300	3 X R0.2	4	30	70	6		2COR 040 010 300	4 X R1	5	30	70	6	
2COR 030 002 350	3 X R0.2	4	35	75	6		2COR 040 010 400	4 X R1	5	40	80	6	
2COR 030 002 400	3 X R0.2	4	40	80	6		2COR 060 001 200	6 X R0.1	7	20	60	6	
2COR 030 003 100	3 X R0.3	4	10	55	6		2COR 060 002 200	6 X R0.2	7	20	60	6	
2COR 030 003 120	3 X R0.3	4	12	55	6		2COR 060 003 200	6 X R0.3	7	20	60	6	
2COR 030 003 160	3 X R0.3	4	16	55	6		2COR 060 005 200	6 X R0.5	7	20	60	6	
2COR 030 003 200	3 X R0.3	4	20	60	6		2COR 060 010 200	6 X R1	7	20	60	6	
2COR 030 003 250	3 X R0.3	4	25	65	6		2COR 060 015 200	6 X R1.5	7	20	60	6	
2COR 030 003 300	3 X R0.3	4	30	70	6		2COR 080 005 250	8 X R0.5	9	25	65	8	
2COR 030 003 350	3 X R0.3	4	35	75	6		2COR 080 010 250	8 X R1	9	25	65	8	
2COR 030 003 400	3 X R0.3	4	40	80	6		2COR 080 015 250	8 X R1.5	9	25	65	8	
2COR 030 005 100	3 X R0.5	4	10	55	6		2COR 100 005 320	10 X R0.5	11	32	70	10	
2COR 030 005 120	3 X R0.5	4	12	55	6		2COR 100 010 320	10 X R1	11	32	70	10	
2COR 030 005 160	3 X R0.5	4	16	55	6		2COR 100 015 320	10 X R1.5	11	32	70	10	
2COR 030 005 200	3 X R0.5	4	20	60	6		2COR 120 005 380	12 X R0.5	12	38	80	12	
2COR 030 005 250	3 X R0.5	4	25	65	6		2COR 120 010 380	12 X R1	12	38	80	12	
2COR 030 005 300	3 X R0.5	4	30	70	6		2COR 120 015 380	12 X R1.5	12	38	80	12	
2COR 030 005 350	3 X R0.5	4	35	75	6								
2COR 030 005 400	3 X R0.5	4	40	80	6								
2COR 030 010 100	3 X R1	4	10	55	6								
2COR 030 010 120	3 X R1	4	12	55	6								
2COR 030 010 160	3 X R1	4	16	55	6								
2COR 030 010 200	3 X R1	4	20	60	6								
2COR 030 010 250	3 X R1	4	25	65	6								
2COR 030 010 300	3 X R1	4	30	70	6								
2COR 030 010 350	3 X R1	4	35	75	6								
2COR 030 010 400	3 X R1	4	40	80	6								
2COR 040 001 120	4 X R0.1	5	12	55	6								
2COR 040 001 160	4 X R0.1	5	16	55	6								
2COR 040 001 200	4 X R0.1	5	20	60	6								
2COR 040 001 300	4 X R0.1	5	30	70	6								
2COR 040 001 400	4 X R0.1	5	40	80	6								
2COR 040 002 120	4 X R0.2	5	12	55	6								
2COR 040 002 160	4 X R0.2	5	16	55	6								
2COR 040 002 200	4 X R0.2	5	20	60	6								
2COR 040 002 300	4 X R0.2	5	30	70	6								
2COR 040 002 400	4 X R0.2	5	40	80	6								
2COR 040 003 120	4 X R0.3	5	12	55	6								
2COR 040 003 160	4 X R0.3	5	16	55	6								
2COR 040 003 200	4 X R0.3	5	20	60	6								
2COR 040 003 300	4 X R0.3	5	30	70	6								
2COR 040 003 400	4 X R0.3	5	40	80	6								
2COR 040 005 120	4 X R0.5	5	12	55	6								

FOR COPPER

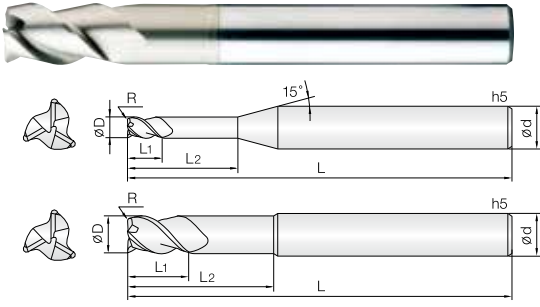

- 동 및 동합금, 알루미늄 합금, 비철합금 가공용 엔드밀
- JCRO 코팅 처리하여 다양한 피삭재 가공시 인선부에 스트레스가 적으며, 피삭재의 면조도가 향상됩니다.
- 3날 45° 헬릭스 형상과 깊은 포켓으로 설계하여 칩배출이 원활하며, 고속, 고이송 작업에 적합합니다.
- 항절력이 높은 미립자 초경합금 (0.5µm)을 채택, 엔드밀의 파손을 최소화.
- Endmills for copper, copper alloys, non-ferrous and non-metallic materials
- JCRO coating provides wear resistance improvement as well as avoid edge stress in various applications.
- High speed, feed applicable by 3 flute 45° degree helix and deep chip pocket design.
- Minimize fracturing by high TRS fine(0.5µm) WC grade.



R0.1 ~ 0.5 R1 481P

Condition	D Size	D Tolerance	Condition	D Size	D Tolerance
ØD ≠ Ød	Ø1 ~ 25	+0 ~ -0.01mm	ØD = Ød	Ø3 ~ 12	-0.005 ~ -0.015mm
				Ø12.1 ~ 25	-0.01 ~ -0.02mm

단위 : mm

Order Number	날경 Diameter D × R	날장 Length of cut L1	유효장 Effective Length L2	전장 Overall Length L	샙크 Shank Dia d	비고	Order Number	날경 Diameter D × R	날장 Length of cut L1	유효장 Effective Length L2	전장 Overall Length L	샙크 Shank Dia d	비고
3COR 010 001 030	1 X R0.1	1.5	3	45	4		3COR 060 005 200	6 X R0.5	9	20	55	6	
3COR 010 001 060	1 X R0.1	1.5	6	45	4		3COR 060 005 300	6 X R0.5	9	30	70	6	
3COR 010 001 100	1 X R0.1	1.5	10	45	4		3COR 060 010 200	6 X R1	9	20	55	6	
3COR 010 002 030	1 X R0.2	1.5	3	45	4		3COR 060 010 300	6 X R1	9	30	70	6	
3COR 010 002 060	1 X R0.2	1.5	6	45	4		3COR 080 003 S08	8 X R0.3	12	25	65	8	
3COR 010 002 100	1 X R0.2	1.5	10	45	4		3COR 080 005 S08	8 X R0.5	12	25	65	8	
3COR 015 001 050	1.5 X R0.1	2	5	45	4		3COR 080 010 S08	8 X R1	12	25	65	8	
3COR 015 001 080	1.5 X R0.1	2	8	45	4		3COR 100 005 S10	10 X R0.5	15	30	70	10	
3COR 015 001 120	1.5 X R0.1	2	12	45	4		3COR 100 010 S10	10 X R1	15	30	70	10	
3COR 015 002 050	1.5 X R0.2	2	5	45	4		3COR 120 005 S12	12 X R0.5	20	35	80	12	
3COR 015 002 080	1.5 X R0.2	2	8	45	4		3COR 120 010 S12	12 X R1	20	35	80	12	
3COR 015 002 120	1.5 X R0.2	2	12	45	4								
3COR 020 001 060	2 X R0.1	3	6	45	4								
3COR 020 001 100	2 X R0.1	3	10	45	4								
3COR 020 001 140	2 X R0.1	3	14	45	4								
3COR 020 002 060	2 X R0.2	3	6	45	4								
3COR 020 002 100	2 X R0.2	3	10	45	4								
3COR 020 002 140	2 X R0.2	3	14	45	4								
3COR 025 001 080	2.5 X R0.1	3.5	8	45	4								
3COR 025 001 120	2.5 X R0.1	3.5	12	45	4								
3COR 025 001 160	2.5 X R0.1	3.5	16	45	4								
3COR 025 002 080	2.5 X R0.2	3.5	8	45	4								
3COR 025 002 120	2.5 X R0.2	3.5	12	45	4								
3COR 025 002 160	2.5 X R0.2	3.5	16	45	4								
3COR 025 005 080	2.5 X R0.5	3.5	8	45	4								
3COR 025 005 120	2.5 X R0.5	3.5	12	45	4								
3COR 025 005 160	2.5 X R0.5	3.5	16	45	4								
3COR 030 002 100	3 X R0.2	4	10	50	4								
New 3COR 030 002 120	3 X R0.2	4	12	50	4								
3COR 030 002 160	3 X R0.2	4	16	50	4								
3COR 030 002 200	3 X R0.2	4	20	50	4								
3COR 030 003 100	3 X R0.3	4	10	50	4								
New 3COR 030 003 120	3 X R0.3	4	12	50	4								
3COR 030 003 160	3 X R0.3	4	16	50	4								
3COR 030 003 200	3 X R0.3	4	20	50	4								
3COR 030 005 100	3 X R0.5	4	10	50	4								
New 3COR 030 005 120	3 X R0.5	4	12	50	4								
3COR 030 005 160	3 X R0.5	4	16	50	4								
3COR 030 005 200	3 X R0.5	4	20	50	4								
3COR 040 002 120	4 X R0.2	6	12	50	4								
3COR 040 002 160	4 X R0.2	6	16	50	4								
3COR 040 002 200	4 X R0.2	6	20	50	4								
3COR 040 003 120	4 X R0.3	6	12	50	4								
3COR 040 003 160	4 X R0.3	6	16	50	4								
3COR 040 003 200	4 X R0.3	6	20	50	4								
3COR 040 005 120	4 X R0.5	6	12	50	4								
3COR 040 005 160	4 X R0.5	6	16	50	4								
3COR 040 005 200	4 X R0.5	6	20	50	4								
3COR 060 003 200	6 X R0.3	9	20	55	6								
3COR 060 003 300	6 X R0.3	9	30	70	6								