

MGEH Grooving Tools (Depth < 20mm)

MGEH 外徑切槽刀 (切深 < 20mm)

External Tool Holder Specifications 外徑刀桿規格

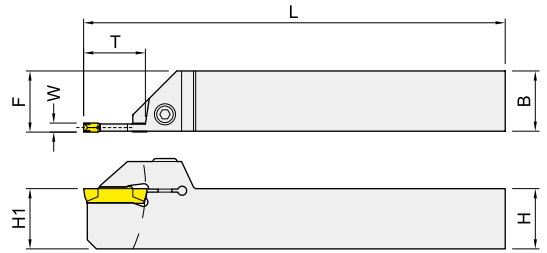
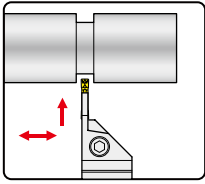

Right-hand shown

Insert Brand : Winstar, Korloy, ...

Order No.	Dimensions (mm)						Inserts	Screw	Wrench
	H (H1)	B	L	F	T	W			
IMGEH ^R / _L 1616K2T16T	16	16	125	16.25	16	2.0	MGMN200.. MRMN200..	IHTMT520	IETL25
IMGEH ^R / _L 2020K2T20T	20	20	125	20.25	20	2.0		IHTMT525	IETL25
IMGEH ^R / _L 2525M2T20T	25	25	150	25.25	20	2.0		IHTMT525	IETL25
IMGEH ^R / _L 1616K3T20T	16	16	125	16.30	20	3.0	MGMN300.. MRMG300..	IHTMT520	IETL25
IMGEH ^R / _L 2020K3T20T	20	20	125	20.30	20	3.0		IHTMT525	IETL25
IMGEHR2525M3T20T	25	25	150	25.30	20	3.0		IHTMT525	IETL25
IMGEHR2525M4T20T	25	25	150	25.35	20	4.0	MGMN400.. MRMN400..	IHTMT525	IETL25

MGIV Grooving Tools (Depth < 15mm) MGIV 內徑切槽刀 (切深 < 15mm)

Internal Tool Holder Specifications 內徑刀桿規格

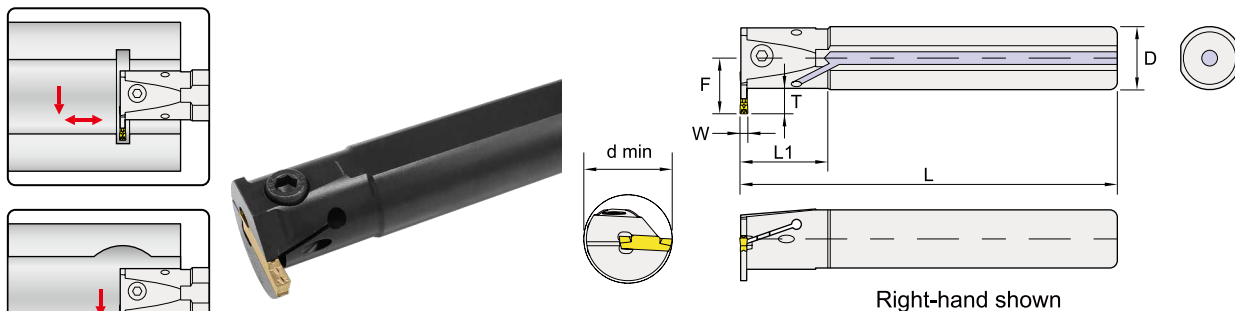

Insert Brand : Winstar, Korloy, ...

Order No.	Dimensions (mm)							Insert	Screw	Wrench
	D	L	L1	F	T	W	d min			
IMGIVR2016M2	16	150	25	12	4	2	20	MGMN200.. MRMN200..	ICSH0310	IPL25
IMGIVR2520M2	20	150	25	14.5	4	2	25		ICSH0512	IPL40
IMGIVR2925R2	25	200	30	16	4	2	29		ICSH0516	IPL40
IMGIVR2620M3	20	150	25	16.5	6	3	26	MGMN300.. MRMG300..	ICSH0512	IPL40
IMGIVR3020M3	20	150	25	20	10	3	30		ICSH0512	IPL40
IMGIVR3125R3	25	200	30	18	6	3	31		ICSH0516	IPL40
IMGIVR3525R3	25	200	30	22	10	3	35		ICSH0516	IPL40
IMGIVR3832S3	32	250	40	21.5	6	3	38		ICSH0516	IPL40
IMGIVR4232S3	32	250	40	25.5	10	3	42		ICSH0516	IPL40
IMGIVR2620M4	20	150	25	15.5	6	4	26		MGMN400.. MRMN400..	ICSH0512
IMGIVR3020M4	20	150	25	20	10	4	30	ICSH0512		IPL40
IMGIVR3125R4	25	200	30	18.5	6	4	31	ICSH0516		IPL40
IMGIVR3525R4	25	200	30	22.5	10	4	35	ICSH0516		IPL40
IMGIVR3832S4	32	250	40	22	6	4	38	ICSH0516		IPL40
IMGIVR4232S4	32	250	40	26	10	4	42	ICSH0516		IPL40
IMGIVR5040T4	40	300	45	29.5	10	4	50	ICSH0516		IPL40
IMGIVR5540T4	40	300	45	34.5	15	4	55	ICSH0516		IPL40

Recommended Cutting Conditions 建議切削數據

Working Material	Vc (m/min)	Parting off, fr (mm/rev)			Grooving, fr (mm/rev)		
		Cutting Width (w)					
		2	3	4	2	3	4
Carbon Steel / Alloy Steel	80 ~ 200	0.02 ~ 0.14	0.03 ~ 0.21	0.04 ~ 0.28	0.04 ~ 0.08	0.06 ~ 0.12	0.08 ~ 0.16
Stainless Steel	60 ~ 140	0.02 ~ 0.10	0.03 ~ 0.15	0.04 ~ 0.20	0.04 ~ 0.06	0.06 ~ 0.09	0.08 ~ 0.12
Cast Iron	80 ~ 200	0.04 ~ 0.14	0.06 ~ 0.21	0.08 ~ 0.28	0.04 ~ 0.08	0.06 ~ 0.12	0.08 ~ 0.16
High Temperature Alloy	50 ~ 100	0.02 ~ 0.06	0.03 ~ 0.09	0.04 ~ 0.12	0.02 ~ 0.04	0.03 ~ 0.06	0.04 ~ 0.08

Insert Specifications 刀片規格

Insert	Dimensions (mm)					Chipbreaker 斷屑槽	
	w	r	l	h	m	SG	MG
MGMN200	2.0	0.2	16	3.5	1.60	SG	For light cutting 適合輕加工
MGMN300	3.0	0.4	21	4.8	2.35		
MGMN400	4.0	0.4	21	4.8	3.30	MG	For general cutting 適合一般泛用加工
MRMN200	2.0	1.0	16	3.5	1.60		
MRMN300	3.0	1.5	21	4.8	2.35		
MRMN400	4.0	2.0	21	4.8	3.30		

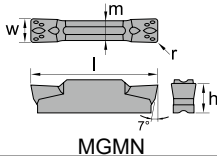
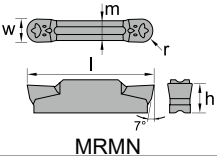



Insert Designation 刀片型號

Insert	Order No.	Code-Chipbreaker-Grade	Working Material					
			P	M	K	N	S	H
	IMGMN200SG33TX	MGMN200-SG-CX33TX	●	●	●		●	●
	IMGMN200SG43TX	MGMN200-SG-CX43TX	●	●	●		○	
	IMGMN300MG33TX	MGMN300-MG-CX33TX	●	●	●		●	●
	IMGMN300MG43TX	MGMN300-MG-CX43TX	●	●	●		○	
	IMGMN400MG33TX	MGMN400-MG-CX33TX	●	●	●		●	●
	IMGMN400MG43TX	MGMN400-MG-CX43TX	●	●	●		○	
	IMRMN200MG33TX	MRMN200-MG-CX33TX	●	●	●		●	●
	IMRMN200MG43TX	MRMN200-MG-CX43TX	●	●	●		○	
	IMRMN300MG33TX	MRMN300-MG-CX33TX	●	●	●		●	●
	IMRMN300MG43TX	MRMN300-MG-CX43TX	●	●	●		○	
	IMRMN400MG33TX	MRMN400-MG-CX33TX	●	●	●		●	●
	IMRMN400MG43TX	MRMN400-MG-CX43TX	●	●	●		○	

* CX33TX for General cutting.
CX43TX for Interrupted cutting.

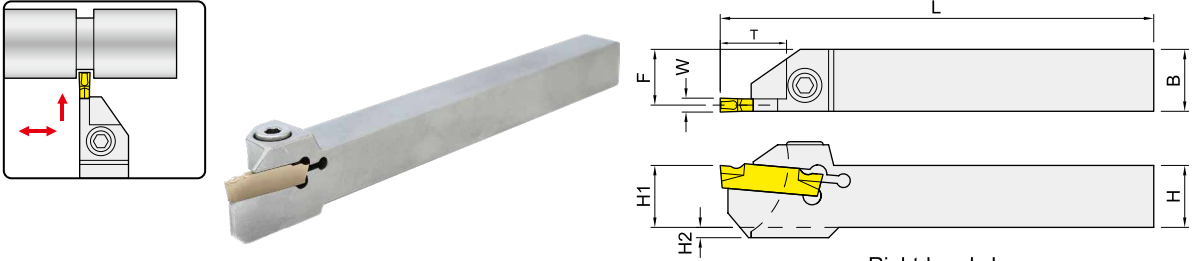
External Tool Holder Specifications 外徑刀桿規格



Right-hand shown

Insert Brand : Winstar, Kyocera, ...

Order No.	Dimensions (mm)						W (mm)		Inserts	Screw	Wrench	
	H (H1)	B	L	F	T	H2	min	max				
IKGM ^R / _L 1212K1.5L10	12	12	125	11.4	10	2	1.5	2.0	GMM2020..	IHTM416	IPL30	
IKGM ^R / _L 1616K1.5L10	16	16	125	15.4	10	-	1.5	2.0		IHTMT520	IETL25	
IKGM ^R / _L 2020K1.5L10	20	20	125	19.4	10	-	1.5	2.0		IHTMT525	IETL25	
IKGM ^R / _L 2525M1.5L10	25	25	150	24.4	10	-	1.5	2.0		IHTMT525	IETL25	
IKGM ^R / _L 1212K2TL10	12	12	125	11.1	10	2	2.0	3.0	GMM2020.. GMM2520.. GMM3020..	IHTM416	IPL30	
IKGM ^R / _L 1616K2TL10	16	16	125	15.1	10	-	2.0	3.0		IHTMT520	IETL25	
IKGM ^R / _L 2020K2TL10	20	20	125	19.1	10	-	2.0	3.0		IHTMT525	IETL25	
IKGM ^R / _L 2525M2TL10	25	25	150	24.1	10	-	2.0	3.0		IHTMT525	IETL25	
IKGM ^R / _L 1212K2TL13	12	12	125	11.1	13	3	2.0	3.0		IHTM420	IPL30	
IKGM ^R / _L 1616K2TL13	16	16	125	15.1	13	-	2.0	3.0		IHTMT520	IETL25	
IKGM ^R / _L 2020K2TL13	20	20	125	19.1	13	-	2.0	3.0		IHTMT525	IETL25	
IKGM ^R / _L 2525M2TL13	25	25	150	24.1	13	-	2.0	3.0		IHTMT525	IETL25	
IKGM ^R / _L 1212K2TL17	12	12	125	11.1	17	4	2.0	3.0		IHTM420	IPL30	
IKGM ^R / _L 1616K2TL17	16	16	125	15.1	17	-	2.0	3.0		IHTMT520	IETL25	
IKGM ^R / _L 2020K2TL17	20	20	125	19.1	17	-	2.0	3.0		IHTMT525	IETL25	
IKGM ^R / _L 2525M2TL17	25	25	150	24.1	17	-	2.0	3.0		IHTMT525	IETL25	
IKGM ^R / _L 1616K3TL16	16	16	125	14.8	16	-	3.0	4.0		GMM3020..	IHTMT520	IETL25
IKGM ^R / _L 2020K3TL16	20	20	125	18.8	16	-	3.0	4.0			IHTMT525	IETL25
IKGM ^R / _L 2525M3TL16	25	25	150	23.8	16	-	3.0	4.0			IHTMT525	IETL25
IKGM ^R / _L 1616K3TL20	16	16	125	14.8	20	4	3.0	4.0			IHTMT525	IETL25
IKGM ^R / _L 2020K3TL20	20	20	125	18.8	20	-	3.0	4.0	IHTMT525		IETL25	
IKGM ^R / _L 2525M3TL20	25	25	150	23.8	20	-	3.0	4.0	IHTMT525		IETL25	
IKGMR3232P3TL20	32	32	170	30.8	20	-	3.0	4.0	IHTMT525		IETL25	

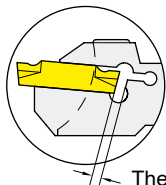

The GMM series inserts need to be installed 0.5~1mm away from the bottom.

KIGM Grooving Tools (Depth < 9mm)

KIGM 內徑切槽刀 (切深 < 9mm)

Internal Tool Holder Specifications 內徑刀桿規格

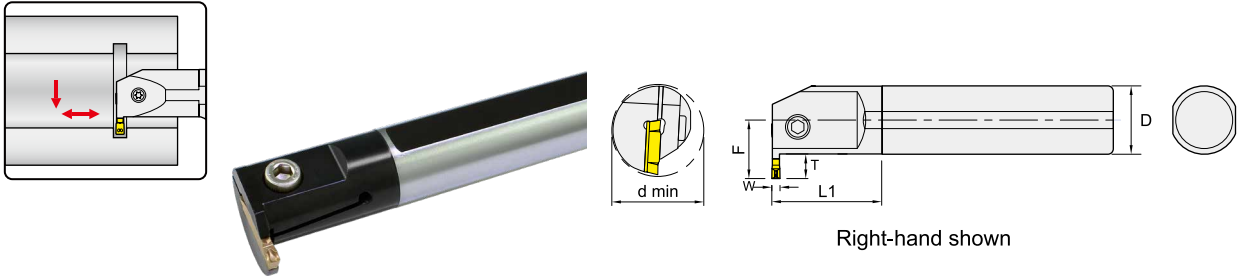

Insert Brand : Winstar, Kyocera, ...

Order No.	Dimensions (mm)							Inserts	Screw	Wrench
	D	L	L1	F	T	W	d min			
IKIGMRS20Q3T07	20	180	35	17	7	3	28	GMM3020..	IHTM516	IPL40
IKIGMRS25R3T09	25	200	40	21.5	9	3	35		IHTMT520	IETL25

The GMM3020R03 inserts need to be installed 0.5~1mm away from the bottom.

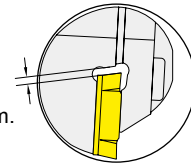

Recommended Cutting Conditions 建議切削數據

Working Material	Vc (m/min)	Parting off, fr (mm/rev)		Grooving, fr (mm/rev)	
		Cutting Width (w)			
		2	3	2	3
Carbon Steel / Alloy Steel	80 ~ 200	0.02 ~ 0.14	0.03 ~ 0.21	0.04 ~ 0.08	0.06 ~ 0.12
Stainless Steel	60 ~ 140	0.02 ~ 0.10	0.03 ~ 0.15	0.04 ~ 0.06	0.06 ~ 0.09
Cast Iron	80 ~ 200	0.04 ~ 0.14	0.06 ~ 0.21	0.04 ~ 0.08	0.06 ~ 0.12
High Temperature Alloy	50 ~ 100	0.02 ~ 0.06	0.03 ~ 0.09	0.02 ~ 0.04	0.03 ~ 0.06

Turning

Insert Specifications 刀片規格



Insert	Dimensions (mm)						Fig.	Chipbreaker 斷屑槽	
	w	r	l	h	m	k°		MR	For high feed cutting 適合高進給加工
GMM2020	2.0	0.20	20	4.3	1.5	-	1		
GMM2020R06	2.0	-	20	4.3	1.5	6°	2		
GMM2020R15	2.0	-	20	4.3	1.5	15°	2		
GMM2020L15	2.0	-	20	4.3	1.5	15°	3		
GMM2520	2.5	0.20	20	4.3	1.9	-	1		
GMM2520R06	2.5	-	20	4.3	1.9	6°	2		
GMM2520R15	2.5	-	20	4.3	1.9	15°	2		
GMM2520L15	2.5	-	20	4.3	1.9	15°	3		
GMM3020	3.0	0.25	20	4.3	2.3	-	1		
GMM3020R06	3.0	-	20	4.3	2.3	6°	2		
GMM3020R15	3.0	-	20	4.3	2.3	15°	2		
GMM3020L15	3.0	-	20	4.3	2.3	15°	3		

Fig. 1

Fig. 2

Fig. 3

Insert Designation 刀片型號

Insert	Order No.	Code-Chipbreaker-Grade	Working Material					
			P	M	K	N	S	H
	IGMM2020MR33TX	GMM2020-MR-CX33TX	●	●	●		●	●
	IGMM2020MR43TX	GMM2020-MR-CX43TX	●	●	●		○	
	IGMM2520MR33TX	GMM2520-MR-CX33TX	●	●	●		●	●
	IGMM3020MR33TX	GMM3020-MR-CX33TX	●	●	●		●	●
	IGMM2020R06MR33TX	GMM2020R06-MR-CX33TX	●	●	●		●	●
	IGMM2020R06MR43TX	GMM2020R06-MR-CX43TX	●	●	●		○	
	IGMM2520R06MR33TX	GMM2520R06-MR-CX33TX	●	●	●		●	●
	IGMM3020R06MR33TX	GMM3020R06-MR-CX33TX	●	●	●		●	●
	IGMM2020R15MR33TX	GMM2020R15-MR-CX33TX	●	●	●		●	●
	IGMM2020L15MR33TX	GMM2020L15-MR-CX33TX	●	●	●		●	●
	IGMM2020R15MR43TX	GMM2020R15-MR-CX43TX	●	●	●		○	
	IGMM2020L15MR43TX	GMM2020L15-MR-CX43TX	●	●	●		○	
	IGMM2520R15MR33TX	GMM2520R15-MR-CX33TX	●	●	●		●	●
	IGMM2520L15MR33TX	GMM2520L15-MR-CX33TX	●	●	●		●	●
	IGMM3020R15MR33TX	GMM3020R15-MR-CX33TX	●	●	●		○	●
	IGMM3020L15MR33TX	GMM3020L15-MR-CX33TX	●	●	●		○	●

* CX33TX for General cutting.
CX43TX for Interrupted cutting.

External Tool Holder Specifications 外徑刀桿規格

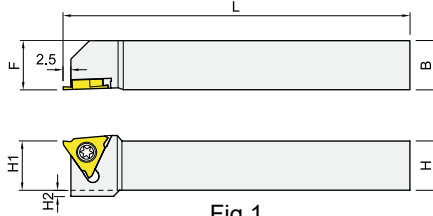
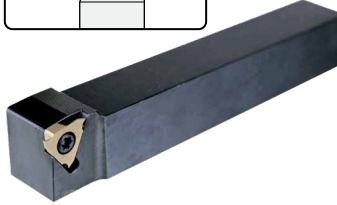
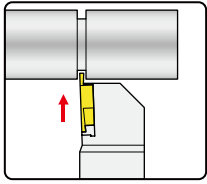

Fig 1

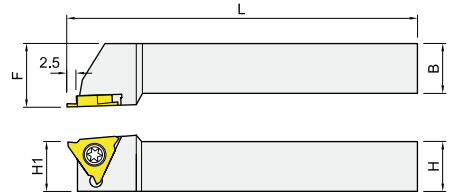
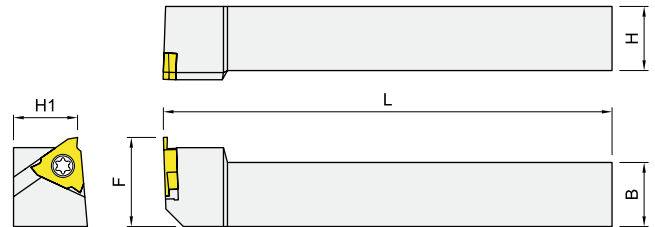
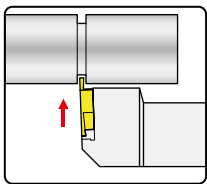

Fig 2

Right-hand shown

Insert Brand : Winstar, Kyocera, ...

Order No.	Dimensions (mm)					Insert	Screw	Wrench	Fig
	H(H1)	B	L	H2	F				
IKTGF ^R / _L 1010K16F	10	10	125	4	10	TGF32R TGF32L	IMS4009A	ITK15	1
IKTGF ^R 1012K16F	10	12	125	2	12				
IKTGF ^R / _L 1212K16F	12	12	125	2	12				
IKTGF ^R / _L 1616K16F	16	16	125	-	16				
IKTGF ^R 2020K16F	20	20	125	-	20	TGF32R	IMS4011A	ITK15	2
IKTGF ^R / _L 1616K16	16	16	125	-	20				
IKTGF ^R / _L 2020K16	20	20	125	-	25	TGF32R TGF32L			
IKTGF ^R / _L 2525M16	25	25	150	-	32				



Left-hand shown

Insert Brand : Winstar, Kyocera, ...

Order No.	Dimensions (mm)				Insert	Screw	Wrench
	H(H1)	B	L	F			
IKTGFSL1616K16	16	16	125	22	TGF32R	IMS4009A	ITK15
IKTGFSL2020K16	20	20	125	26			



Turning

KTGF Shallow Grooving Tools (Vertical , Depth < 2.5mm)

KTGF 外徑淺切槽刀 (立式, 切深 < 2.5mm)

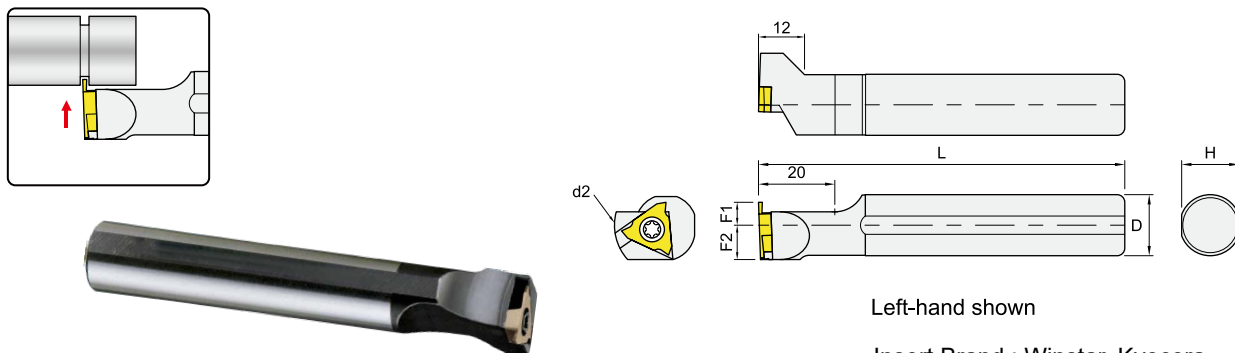
External Tool Holder Specifications 外徑刀桿規格



Order No.	Dimensions (mm)						Insert	Screw 	Wrench 
	D	L	H	F1	F2	d2			
IS16HKTGFL16	16	100	15	6	9	27	TGF32R	IMS4009A	ITK15

Recommended Cutting Conditions 建議切削數據

Working Material	Vc (m/min)	fr (mm/rev)
Carbon Steel / Alloy Steel	50 ~ 200	0.02 ~ 0.10
Stainless Steel	50 ~ 200	0.02 ~ 0.10
Cast Iron	50 ~ 200	0.02 ~ 0.10
Aluminum Alloy	200 ~ 300	0.05 ~ 0.15
High Temperature Alloy	80 ~ 120	0.03 ~ 0.07

Insert Designation 刀片型號

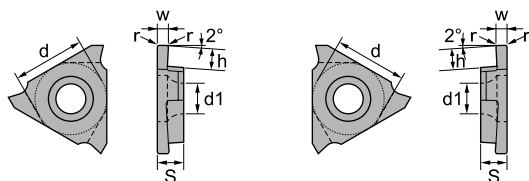

Right hand

Left hand

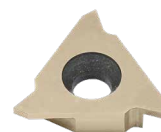

Order No.	Designation	Dimensions (mm)						Max Depth of Cut		Working Material					
		w	h	r	S	d	d1	O.D.	I.D.	P	M	K	N	S	H
ITGF32R0336025	TGF32R033-CP6025	0.33	1.0	0.05	3.18	9.525	4.4	0.8	0.5	●	●	●		○	○
ITGF32L0336025	TGF32L033-CP6025	0.33	1.0	0.05	3.18	9.525	4.4	0.8	0.5	●	●	●		○	○
ITGF32R0506025	TGF32R050-CP6025	0.50	1.4	0.05	3.18	9.525	4.4	1.2	0.8	●	●	●		○	○
ITGF32L0506025	TGF32L050-CP6025	0.50	1.4	0.05	3.18	9.525	4.4	1.2	0.8	●	●	●		○	○
ITGF32R0756025	TGF32R075-CP6025	0.75	2.5	0.1	3.18	9.525	4.4	2.0	1.5	●	●	●		○	○
ITGF32L0756025	TGF32L075-CP6025	0.75	2.5	0.1	3.18	9.525	4.4	2.0	1.5	●	●	●		○	○
ITGF32R0956025	TGF32R095-CP6025	0.95	2.5	0.1	3.18	9.525	4.4	2.0	1.5	●	●	●		○	○
ITGF32L0956025	TGF32L095-CP6025	0.95	2.5	0.1	3.18	9.525	4.4	2.0	1.5	●	●	●		○	○
ITGF32R1006025	TGF32R100-CP6025	1.00	2.5	0.1	3.18	9.525	4.4	2.0	1.5	●	●	●		○	○
ITGF32L1006025	TGF32L100-CP6025	1.00	2.5	0.1	3.18	9.525	4.4	2.0	1.5	●	●	●		○	○
ITGF32R1106025	TGF32R110-CP6025	1.10	2.5	0.1	3.18	9.525	4.4	2.0	1.5	●	●	●		○	○
ITGF32L1106025	TGF32L110-CP6025	1.10	2.5	0.1	3.18	9.525	4.4	2.0	1.5	●	●	●		○	○
ITGF32R1256025	TGF32R125-CP6025	1.25	2.5	0.1	3.18	9.525	4.4	2.0	1.5	●	●	●		○	○
ITGF32L1256025	TGF32L125-CP6025	1.25	2.5	0.1	3.18	9.525	4.4	2.0	1.5	●	●	●		○	○
ITGF32R1356025	TGF32R135-CP6025	1.35	2.5	0.1	3.18	9.525	4.4	2.0	1.5	●	●	●		○	○
ITGF32L1356025	TGF32L135-CP6025	1.35	2.5	0.1	3.18	9.525	4.4	2.0	1.5	●	●	●		○	○
ITGF32R1456025	TGF32R145-CP6025	1.45	2.5	0.1	3.18	9.525	4.4	2.0	1.5	●	●	●		○	○
ITGF32L1456025	TGF32L145-CP6025	1.45	2.5	0.1	3.18	9.525	4.4	2.0	1.5	●	●	●		○	○
ITGF32R1506025	TGF32R150-CP6025	1.50	2.5	0.1	3.18	9.525	4.4	2.0	1.5	●	●	●		○	○
ITGF32L1506025	TGF32L150-CP6025	1.50	2.5	0.1	3.18	9.525	4.4	2.0	1.5	●	●	●		○	○
ITGF32R1656025	TGF32R165-CP6025	1.65	2.5	0.1	3.18	9.525	4.4	2.0	1.5	●	●	●		○	○
ITGF32L1656025	TGF32L165-CP6025	1.65	2.5	0.1	3.18	9.525	4.4	2.0	1.5	●	●	●		○	○
ITGF32R1756025	TGF32R175-CP6025	1.75	2.5	0.1	3.18	9.525	4.4	2.0	1.5	●	●	●		○	○
ITGF32L1756025	TGF32L175-CP6025	1.75	2.5	0.1	3.18	9.525	4.4	2.0	1.5	●	●	●		○	○
ITGF32R1806025	TGF32R180-CP6025	1.80	2.5	0.1	3.18	9.525	4.4	2.0	1.5	●	●	●		○	○
ITGF32L1806025	TGF32L180-CP6025	1.80	2.5	0.1	3.18	9.525	4.4	2.0	1.5	●	●	●		○	○
ITGF32R1856025	TGF32R185-CP6025	1.85	2.5	0.1	3.18	9.525	4.4	2.0	1.5	●	●	●		○	○
ITGF32L1856025	TGF32L185-CP6025	1.85	2.5	0.1	3.18	9.525	4.4	2.0	1.5	●	●	●		○	○
ITGF32R1956025	TGF32R195-CP6025	1.95	2.5	0.1	3.18	9.525	4.4	2.0	1.5	●	●	●		○	○
ITGF32L1956025	TGF32L195-CP6025	1.95	2.5	0.1	3.18	9.525	4.4	2.0	1.5	●	●	●		○	○
ITGF32R2006025	TGF32R200-CP6025	2.00	2.5	0.1	3.18	9.525	4.4	2.0	1.5	●	●	●		○	○
ITGF32L2006025	TGF32L200-CP6025	2.00	2.5	0.1	3.18	9.525	4.4	2.0	1.5	●	●	●		○	○
ITGF32R2506025	TGF32R250-CP6025	2.50	2.5	0.1	3.18	9.525	4.4	2.0	1.5	●	●	●		○	○
ITGF32L2506025	TGF32L250-CP6025	2.50	2.5	0.1	3.18	9.525	4.4	2.0	1.5	●	●	●		○	○

※ To choose CP10(uncoating) for **N** material machining.

TGF Shallow Grooving Tools (Vertical , Depth < 2.5mm) TGF 淺切槽刀 (立式, 切深 < 2.5mm)

Insert Designation 刀片型號

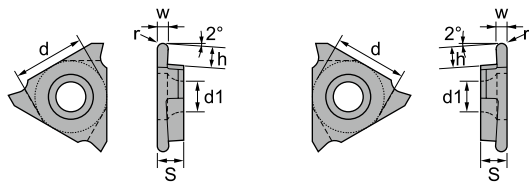

Right hand

Left hand

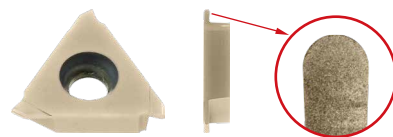

Order No.	Designation	Dimensions (mm)						Max Depth of Cut		Working Material					
		w	h	r	S	d	d1	O.D.	I.D.	P	M	K	N	S	H
ITGF32R025R6025	TGF32R025R-CP6025	0.50	1.4	0.25	3.18	9.525	4.4	1.2	0.8	●	●	●		○	○
ITGF32L025R6025	TGF32L025R-CP6025	0.50	1.4	0.25	3.18	9.525	4.4	1.2	0.8	●	●	●		○	○
ITGF32R037R6025	TGF32R037R-CP6025	0.75	2.5	0.375	3.18	9.525	4.4	2.0	1.5	●	●	●		○	○
ITGF32L037R6025	TGF32L037R-CP6025	0.75	2.5	0.375	3.18	9.525	4.4	2.0	1.5	●	●	●		○	○
ITGF32R050R6025	TGF32R050R-CP6025	1.00	2.5	0.5	3.18	9.525	4.4	2.0	1.5	●	●	●		○	○
ITGF32L050R6025	TGF32L050R-CP6025	1.00	2.5	0.5	3.18	9.525	4.4	2.0	1.5	●	●	●		○	○
ITGF32R062R6025	TGF32R062R-CP6025	1.25	2.5	0.625	3.18	9.525	4.4	2.0	1.5	●	●	●		○	○
ITGF32L062R6025	TGF32L062R-CP6025	1.25	2.5	0.625	3.18	9.525	4.4	2.0	1.5	●	●	●		○	○
ITGF32R075R6025	TGF32R075R-CP6025	1.50	2.5	0.75	3.18	9.525	4.4	2.0	1.5	●	●	●		○	○
ITGF32L075R6025	TGF32L075R-CP6025	1.50	2.5	0.75	3.18	9.525	4.4	2.0	1.5	●	●	●		○	○

※ To choose CP10(uncoating) for **N** material machining.

SE Shallow Grooving Tools (Laydown, Depth < 2.5mm)

SE 外徑淺切槽刀 (臥式, 切深 < 2.5mm)

External Tool Holder Specifications 外徑刀桿規格

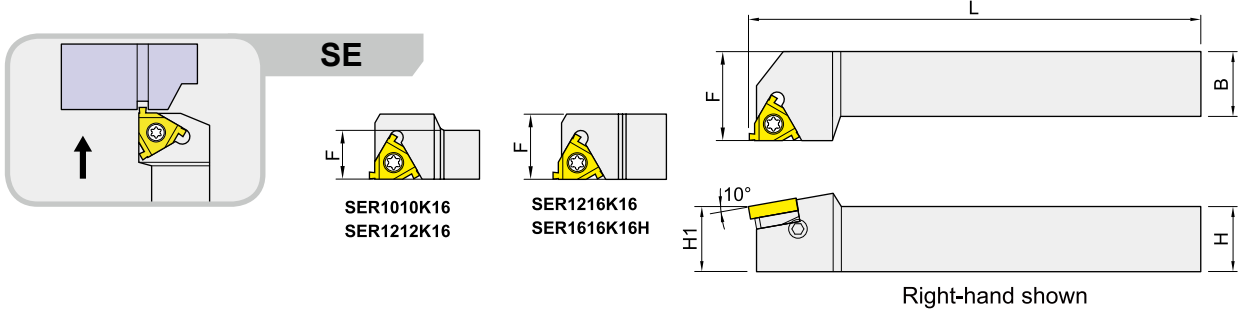

Insert Brand : Winstar

Order No.	Dimensions (mm)				Insert	Spare parts
	H(H1)	B	L	F		
ISE ^{R/L} 1216K16	12	16	125	16	TGL16ER or TGL16EL	①
ISE ^{R/L} 1010K16H	10	10	125	10		
ISE ^{R/L} 1212K16H	12	12	125	12		
ISE ^{R/L} 1616K16H	16	16	125	16		
ISE ^{R/L} 1616K16	16	16	125	20		②
ISE ^{R/L} 2020K16	20	20	125	25		
ISE ^{R/L} 2525M16	25	25	150	32		
ISE ^{R/L} 3232P16	32	32	170	40		

Spare parts	Screw	Shim	Screw	Wrench	Wrench
①	IMS3509A	-	-	-	ITK15
②	IMS3512A	IGXN16 or IGXE16	IHTM309	IPL25	ITK15

※ SER right hand tools shim is IGXE16, SEL left hand tools shim is IGXN16.

SKE Shallow Grooving Tools (Laydown, Depth < 2.5mm)

SKE 外徑 淺切槽刀 (臥式, 切深 < 2.5mm)

External Tool Holder Specifications 外徑刀桿規格

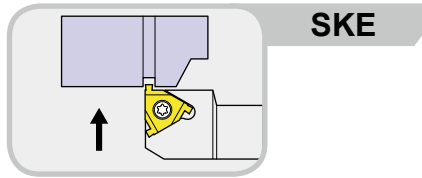

SKE

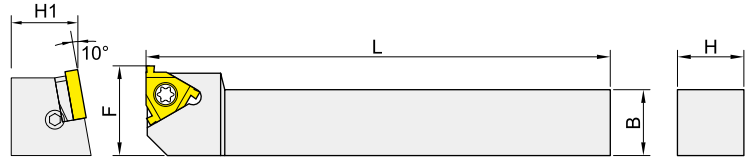

Right-hand shown

Insert Brand : Winstar

Order No.	Dimensions (mm)				Insert	Spare parts
	H(H1)	B	L	F		
ISKE ^R / _L 1212K16	12	12	125	18	TGL16ER or TGL16EL	①
ISKE ^R / _L 1616K16	16	16	125	22		②
ISKE ^R / _L 2020K16	20	20	125	27		
ISKE ^R / _L 2525M16	25	25	150	34		

Spare parts	Screw	Shim	Screw	Wrench	Wrench
①	IMS3509A	-	-	-	ITK15
②	IMS3512A	IGXN16 or IGXE16	IHTM309	IPL25	ITK15

※ SKER right hand tools shim is IGXE16, SKEL left hand tools shim is IGXN16.

SN Shallow Grooving Tools (Laydown, Depth < 2.5mm)

SN 內徑 淺切槽刀 (臥式, 切深 < 2.5mm)

Internal Tool Holder Specifications 內徑刀桿規格

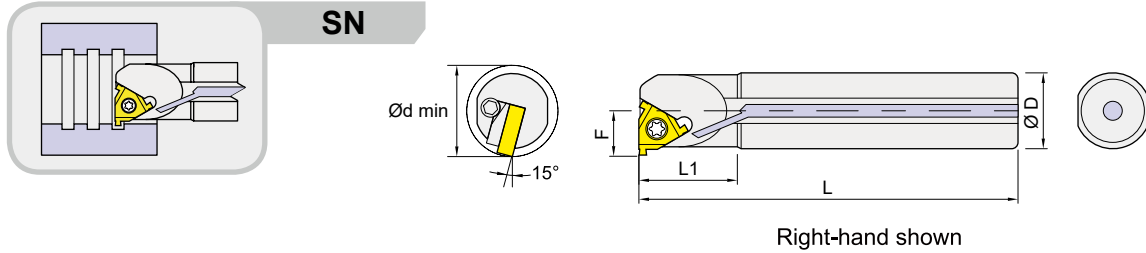

Insert Brand : Winstar

Order No.	Dimensions (mm)					Coolant	Insert	Spare parts
	D	L	L1	F	d min			
ISN ^{R/L} _0010K11S10	10	125	22	6.5	13		TGL11IR or TGL11IL	①
ISN ^{R/L} _0012M11S12	12	150	26	8	16			
ISN ^{R/L} _A0010K11S10	10	125	22	6.5	13	●		
ISN ^{R/L} _A0012M11S12	12	150	26	8	16	●		
ISN ^{R/L} _0016Q16	16	180	36	10	19		TGL16IR or TGL16IL	②
ISN ^{R/L} _0020R16	20	200	40	12	24			③
ISN ^{R/L} _0025R16	25	200	45	14.5	29			③
ISN ^{R/L} _0032S16	32	250	45	18.5	36			②
ISN ^{R/L} _A0016Q16	16	180	36	10	19	●		②
ISN ^{R/L} _A0020R16	20	200	40	12	24	●		③
ISN ^{R/L} _A0025R16	25	200	45	14.5	29	●	③	
ISN ^{R/L} _A0032S16	32	250	45	18.5	36	●	③	

Spare parts	Screw	Wrench	Shim	Screw	Wrench
①	IMS2507G	ITK08	-	-	-
②	IMS3509A	ITK15	-	-	-
③	IMS3512A	ITK15	IGXN16 or IGXE16	IHTM309	IPL25

※ SNR right hand tools shim is IGXN16, SNL left hand tools shim is IGXE16.

Recommended Cutting Conditions 建議切削數據

Working Material	Vc (m/min)	fr (mm/rev)
Carbon Steel / Alloy Steel	50 ~ 200	0.02 ~ 0.10
Stainless Steel	50 ~ 200	0.02 ~ 0.10
Cast Iron	50 ~ 200	0.02 ~ 0.10
Aluminum Alloy	200 ~ 300	0.05 ~ 0.15
High Temperature Alloy	80 ~ 120	0.03 ~ 0.07

Turning

Insert Designation 刀片型號

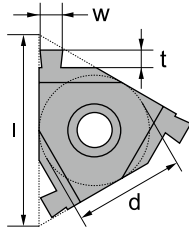

※ Same insert can be used for external right hand and internal left hand.

相同的刀片可以使用在外徑右手與內徑左手加工

Order No.	Designation	Dimensions (mm)				Working Material					
		d	l	w ±0.02	t	P	M	K	N	S	H
ITGL11ER0506025	TGL11ER050-CP6025	1/4	11	0.50	1.4	●	●	●		○	○
ITGL11 IL 0506025	TGL11 IL 050-CP6025	1/4	11	0.50	1.4	●	●	●		○	○
ITGL11ER0606025	TGL11ER060-CP6025	1/4	11	0.60	1.4	●	●	●		○	○
ITGL11 IL 0606025	TGL11 IL 060-CP6025	1/4	11	0.60	1.4	●	●	●		○	○
ITGL11ER0706025	TGL11ER070-CP6025	1/4	11	0.70	1.4	●	●	●		○	○
ITGL11 IL 0706025	TGL11 IL 070-CP6025	1/4	11	0.70	1.4	●	●	●		○	○
ITGL11ER0806025	TGL11ER080-CP6025	1/4	11	0.80	1.4	●	●	●		○	○
ITGL11 IL 0806025	TGL11 IL 080-CP6025	1/4	11	0.80	1.4	●	●	●		○	○
ITGL11ER1006025	TGL11ER100-CP6025	1/4	11	1.00	1.4	●	●	●		○	○
ITGL11 IL 1006025	TGL11 IL 100-CP6025	1/4	11	1.00	1.4	●	●	●		○	○
ITGL11ER1206025	TGL11ER120-CP6025	1/4	11	1.20	1.4	●	●	●		○	○
ITGL11 IL 1206025	TGL11 IL 120-CP6025	1/4	11	1.20	1.4	●	●	●		○	○
ITGL16ER0506025	TGL16ER050-CP6025	3/8	16	0.50	1.4	●	●	●		○	○
ITGL16 IL 0506025	TGL16 IL 050-CP6025	3/8	16	0.50	1.4	●	●	●		○	○
ITGL16ER1006025	TGL16ER100-CP6025	3/8	16	1.00	1.4	●	●	●		○	○
ITGL16 IL 1006025	TGL16 IL 100-CP6025	3/8	16	1.00	1.4	●	●	●		○	○
ITGL16ER1206025	TGL16ER120-CP6025	3/8	16	1.20	1.6	●	●	●		○	○
ITGL16 IL 1206025	TGL16 IL 120-CP6025	3/8	16	1.20	1.6	●	●	●		○	○
ITGL16ER1406025	TGL16ER140-CP6025	3/8	16	1.40	1.8	●	●	●		○	○
ITGL16 IL 1406025	TGL16 IL 140-CP6025	3/8	16	1.40	1.8	●	●	●		○	○
ITGL16ER1706025	TGL16ER170-CP6025	3/8	16	1.70	2.0	●	●	●		○	○
ITGL16 IL 1706025	TGL16 IL 170-CP6025	3/8	16	1.70	2.0	●	●	●		○	○
ITGL16ER1956025	TGL16ER195-CP6025	3/8	16	1.95	2.0	●	●	●		○	○
ITGL16 IL 1956025	TGL16 IL 195-CP6025	3/8	16	1.95	2.0	●	●	●		○	○
ITGL16ER2256025	TGL16ER225-CP6025	3/8	16	2.25	2.25	●	●	●		○	○
ITGL16 IL 2256025	TGL16 IL 225-CP6025	3/8	16	2.25	2.25	●	●	●		○	○

※ To choose CP10(uncoating) for **N** material machining.

Insert Designation 刀片型號

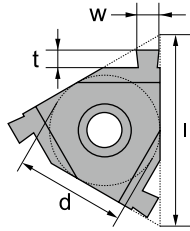

※ Same insert can be used for internal right hand and external left hand.

相同的刀片可以使用在內徑右手與外徑左手加工

Order No.	Designation	Dimensions (mm)				Working Material					
		d	l	w ±0.02	t	P	M	K	N	S	H
ITGL111R0506025	TGL111R050-CP6025	1/4	11	0.50	1.4	●	●	●		○	○
ITGL11EL0506025	TGL11EL050-CP6025	1/4	11	0.50	1.4	●	●	●		○	○
ITGL111R0606025	TGL111R060-CP6025	1/4	11	0.60	1.4	●	●	●		○	○
ITGL11EL0606025	TGL11EL060-CP6025	1/4	11	0.60	1.4	●	●	●		○	○
ITGL111R0706025	TGL111R070-CP6025	1/4	11	0.70	1.4	●	●	●		○	○
ITGL11EL0706025	TGL11EL070-CP6025	1/4	11	0.70	1.4	●	●	●		○	○
ITGL111R0806025	TGL111R080-CP6025	1/4	11	0.80	1.4	●	●	●		○	○
ITGL11EL0806025	TGL11EL080-CP6025	1/4	11	0.80	1.4	●	●	●		○	○
ITGL111R1006025	TGL111R100-CP6025	1/4	11	1.00	1.4	●	●	●		○	○
ITGL11EL1006025	TGL11EL100-CP6025	1/4	11	1.00	1.4	●	●	●		○	○
ITGL111R1206025	TGL111R120-CP6025	1/4	11	1.20	1.4	●	●	●		○	○
ITGL11EL1206025	TGL11EL120-CP6025	1/4	11	1.20	1.4	●	●	●		○	○
ITGL161R0506025	TGL161R050-CP6025	3/8	16	0.50	1.4	●	●	●		○	○
ITGL16EL0506025	TGL16EL050-CP6025	3/8	16	0.50	1.4	●	●	●		○	○
ITGL161R1006025	TGL161R100-CP6025	3/8	16	1.00	1.4	●	●	●		○	○
ITGL16EL1006025	TGL16EL100-CP6025	3/8	16	1.00	1.4	●	●	●		○	○
ITGL161R1206025	TGL161R120-CP6025	3/8	16	1.20	1.6	●	●	●		○	○
ITGL16EL1206025	TGL16EL120-CP6025	3/8	16	1.20	1.6	●	●	●		○	○
ITGL161R1406025	TGL161R140-CP6025	3/8	16	1.40	1.8	●	●	●		○	○
ITGL16EL1406025	TGL16EL140-CP6025	3/8	16	1.40	1.8	●	●	●		○	○
ITGL161R1706025	TGL161R170-CP6025	3/8	16	1.70	2.0	●	●	●		○	○
ITGL16EL1706025	TGL16EL170-CP6025	3/8	16	1.70	2.0	●	●	●		○	○
ITGL161R1956025	TGL161R195-CP6025	3/8	16	1.95	2.0	●	●	●		○	○
ITGL16EL1956025	TGL16EL195-CP6025	3/8	16	1.95	2.0	●	●	●		○	○
ITGL161R2256025	TGL161R225-CP6025	3/8	16	2.25	2.25	●	●	●		○	○
ITGL16EL2256025	TGL16EL225-CP6025	3/8	16	2.25	2.25	●	●	●		○	○

※ To choose CP10(uncoating) for **N** material machining.

SGIH Parting Tools (Depth < 40mm)

SGIH 切斷刀 (切深 < 40mm)

External Tool Holder Specifications 外徑刀桿規格

SGIH

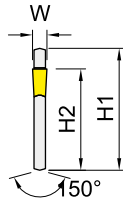
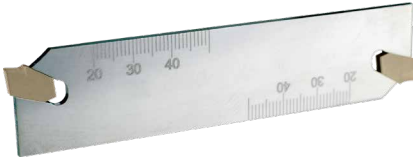

Insert Brand : Winstar, Iscar, ...

Order No.	Dimensions (mm)				Insert	Tool Block	Wrench
	H1	H2	L	W			
ISGIH26-2	26	21.4	110	2.2	TGTN0220	ISGTBU...-26	IESG-1
ISGIH26-3	26	21.4	110	3.1	TGTN0310		
ISGIH26-4	26	21.4	110	4.1	TGTN0410		
ISGIH32-2	32	25	150	2.2	TGTN0220	ISGTBU...-32	
ISGIH32-3	32	25	150	3.1	TGTN0310		
ISGIH32-4	32	25	150	4.1	TGTN0410		

SGTBU

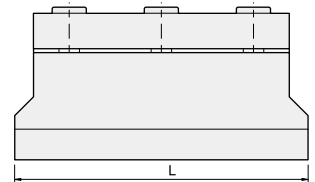
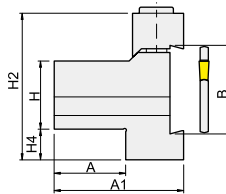

Order No.	Dimensions (mm)							Screw	Wrench	BLADE
	H	B	A	A1	L	H2	H4			
ISGTBU20-26	20	26	21	38	86	43	9	IHTM630	IPL50	ISGIH26-3
ISGTBU25-26	25	26	23	40	86	43	4			
ISGTBU20-32	20	32	21	40	110	50	13			ISGIH32-3
ISGTBU25-32	25	32	23	42	110	50	8			

SGTHR

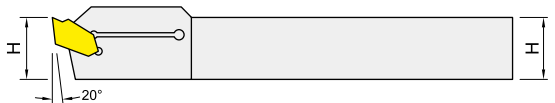
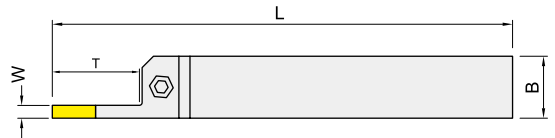

Order No.	Dimensions (mm)					Insert	Screw	Wrench
	H	B	L	W	T			
ISGTHR16162	16	16	110	2	16	TG TN0220	IHTM521	IPL40
ISGTHR20202	20	20	125	2	18			
ISGTHR20203	20	20	125	3	20	TG TN0310	IHTM625	IPL50
ISGTHR25253	25	25	150	3	25			
ISGTHR25254	25	25	150	4	30			

Recommended Cutting Conditions 建議切削數據

Working Material	Vc (m/min)	Parting off, fr (mm/rev)		
		Cutting Width (w)		
		2	3	4
Carbon Steel / Alloy Steel	80 ~ 200	0.02 ~ 0.14	0.03 ~ 0.21	0.04 ~ 0.28
Stainless Steel	60 ~ 140	0.02 ~ 0.10	0.03 ~ 0.15	0.04 ~ 0.20
Cast Iron	80 ~ 200	0.04 ~ 0.14	0.06 ~ 0.21	0.08 ~ 0.28
High Temperature Alloy	50 ~ 100	0.02 ~ 0.06	0.03 ~ 0.09	0.04 ~ 0.12

Insert Specifications 刀片規格

Insert	Dimensions (mm)	
	w	r
TGTN0220	2.2	0.2
TGTN0310	3.1	0.2
TGTN0410	4.1	0.25

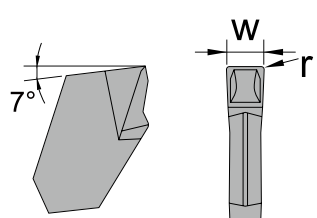

Insert Designation 刀片型號

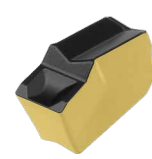
Inserts	Order No.	Code-Grade	Working Material					
			P	M	K	N	S	H
	ITGTN022033TX	TGTN0220-CX33TX	●	●	●		●	●
	ITGTN022043TX	TGTN0220-CX43TX	●	●	●		○	
	ITGTN022047TA	TGTN0220-CX47TA	●	●	●			
	ITGTN031033TX	TGTN0310-CX33TX	●	●	●		●	●
	ITGTN031043TX	TGTN0310-CX43TX	●	●	●		○	
	ITGTN031047TA	TGTN0310-CX47TA	●	●	●			
	ITGTN041033TX	TGTN0410-CX33TX	●	●	●		●	●
	ITGTN041043TX	TGTN0410-CX43TX	●	●	●		○	
	ITGTN041047TA	TGTN0410-CX47TA	●	●	●			

* CX33TX for General cutting.
 CX43TX for Interrupted cutting.
 CX47TA for Heavy interrupted cutting.